

AIREASE®

Built for life. Yours.

Split System Heat Pump

4HP13L-7

FORM NO. J4HP13L-7-100 (10/2011)

Features and Benefits

- R410A Refrigerant
- High-quality condenser coil with copper tubing and enhanced louvered fin for maximum heat transfer capacity
- Top discharge directs hot air and sound away from living area and shrubbery
- All units run tested
- Available with louvered panel coil protection
- Easy access to electrical panels, pre-wired for easy hook-up
- Bi-directional liquid line filter drier factory installed
- Discharge muffler for quiet operation
- Reliable, solid state time/temperature defrost control, with field selectable 30/60/90 minute intervals
- Defrost control is Quiet Shift™ capable
- Low pressure switch factory installed for loss of charge protection
- Integrated control with LED diagnostics
- Short cycle protection factory installed
- Charged for 15 feet of interconnecting tubing



WARRANTY

- 10 year limited warranty on compressor, 10 year limited warranty on all parts, extended warranty available*

*Warranty provides for a total of 10 years of limited warranty coverage (Standard 5-year limited parts warranty plus an additional 5-year limited extended parts warranty). Warranty must be registered online within 60 days of installation to qualify for 10-year coverage. Unregistered equipment defaults to 5-year coverage. Lifetime limited heat exchanger warranty applies to registered equipment only (Standard 20 years with no online registration). See full warranty at www.alliedair.com for terms, conditions and exclusions.

Model Number Guide

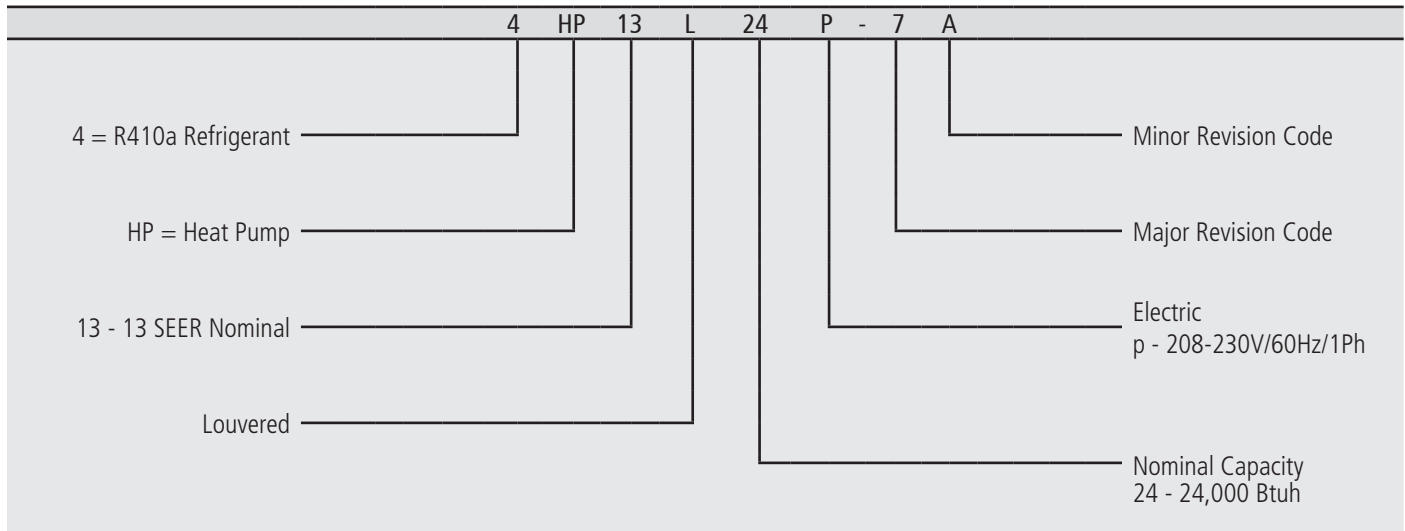

Physical and Electrical Data

Model	Volts/Hz/Phase	Voltage Range	Min. Circuit Amp.	Max. Over-current Device (amps)	Compressor		Fan Motor			Refrig. Charge (oz.)	Shipping Weight (lbs) Louvered
					Rated Load (amps)	Locked Rotor (amps)	Rated Load (amps)	Rated HP	Nom. RPM		
4HP13L18P-7	208-230/60/1	197-253	11.9	20	9.0	48	0.7	1/10	1075	106	153
4HP13L24P-7	208-230/60/1	197-253	14.2	20	10.7	53	0.8	1/10	1075	101	158
4HP13L30P-7	208-230/60/1	197-253	16.3	25	12.4	59	0.7	1/6	825	108	168
4HP13L36P-7	208-230/60/1	197-253	19.9	35	15.2	70	0.9	1/6	825	114	187
4HP13L42P-7	208-230/60/1	197-253	27.8	45	21.1	90	1.4	1/4	825	134	224
4HP13L48P-7	208-230/60/1	197-253	31.7	50	24.1	100	1.5	1/4	825	198	236
4HP13L60P-7	208-230/60/1	197-253	36.3	60	27.6	120	1.7	1/3	825	210	252

Note: Weights listed are unit weights with packaging
 + Factory charged for 15 feet of line set. Adjust per installation instructions.

Unit Dimensions & Sound Ratings

Model	Dimensions			Sound Ratings (dBa)
	A-Width (in.)	B-Depth (in.)	C-Height (in.)	
4HP13L18P-7	24.25	24.25	32.5	76
4HP13L24P-7	24.25	24.25	32.5	76
4HP13L30P-7	28.25	28.25	28.5	76
4HP13L36P-7	28.25	28.25	36.5	76
4HP13L42P-7	28.25	28.25	42.5	80
4HP13L48P-7	28.25	28.25	32.5	80
4HP13L60P-7	28.25	28.25	36.5	80

Note: Dimensions listed are unit sizes without packaging.

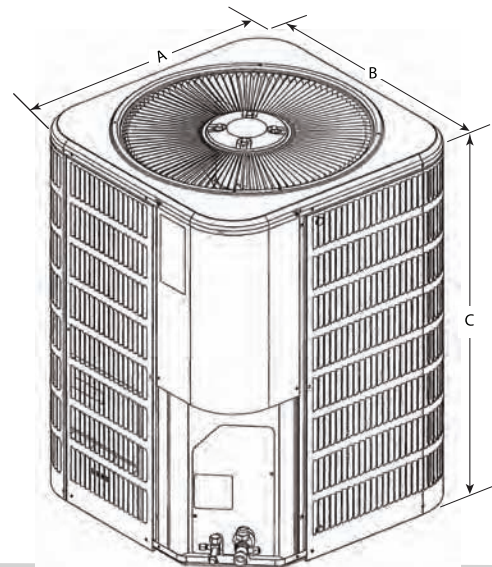

Cooling Performance with Evaporator Coils

Outdoor Model	Indoor Model	Cooling				Heating				CFM	Refrigerant Connection				Refrig. Line Size		Indoor Expansion Device		
		SEER	EER	ARI Rated Capacity ¹ BTUH	Sensible Capacity BTUH	HSPF	47		17		Outdoor		Indoor		Suction	Liquid	Piston ²	TXV	
							Btuh	COP	Btuh		COP	Suction	Liquid	Suction					Liquid
4HP13L 18P-7	E(C,H,M,U)1P18(A,B)	13.00	11.00	18,000	12780	7.70	17000	3.20	10000	2.00	650	3/4	3/8	3/4	3/8	3/4	3/8	NA	H4TXV01
	E(C,H,M,U)1P24(A,B)	13.00	11.00	18,000	12780	7.70	17000	3.20	10000	2.00	650	3/4	3/8	3/4	3/8	3/4	3/8	NA	H4TXV01
4HP13L 24P-7	E(C,H,M,U)1P23(A,B)	13.00	11.00	23,000	16790	7.70	21600	3.30	13000	2.20	850	3/4	3/8	3/4	3/8	3/4	3/8	57	H4TXV01
	E(C,H,M,U)1P24(A,B)	13.00	11.00	23,000	16790	7.70	21600	3.30	13000	2.20	850	3/4	3/8	3/4	3/8	3/4	3/8	57	H4TXV01
4HP13L 30P-7	E(C,H,M,U)1P29(A,B)	13.00	11.00	29,000	21460	7.70	27000	3.40	17000	2.20	1000	3/4	3/8	3/4	3/8	3/4	3/8	62	H4TXV01
	E(C,H,M,U)1P30(B,C)	13.00	11.00	29,000	21460	7.70	27000	3.40	17000	2.20	1000	3/4	3/8	3/4	3/8	3/4	3/8	62	H4TXV01
4HP13L 36P-7	E(C,H,M,U)1P30(B,C)	13.00	11.00	35,000	25200	7.70	33800	3.40	18000	2.20	1275	3/4	3/8	3/4	3/8	3/4	3/8	71	H4TXV01
	E(C,H,M,U)1P36(B,C)	13.00	11.00	35,000	25200	7.70	33800	3.40	18000	2.20	1275	3/4	3/8	3/4	3/8	3/4	3/8	71	H4TXV01
4HP13L 42P-7	E(C,H,M,U)1P36(B,C)	13.00	11.00	41,000	29520	7.70	40000	3.50	25000	2.20	1400	7/8	3/8	7/8	3/8	7/8	3/8	76	H4TXV02
	E(C,H,M,U)1P43(B,C)	13.00	11.00	41,000	29520	7.70	40000	3.50	25000	2.20	1400	7/8	3/8	7/8	3/8	7/8	3/8	76	H4TXV02
4HP13L 48P-7	E(C,H,M,U)1P50(B,C)	13.00	11.00	48,000	34560	7.70	45000	3.20	28000	2.40	1600	7/8	3/8	7/8	3/8	7/8	3/8	80	H4TXV02
4HP13L 60P-7	E(C,H,M,U)1P49(B,C)	13.00	11.00	58,000	41180	7.70	55000	3.30	34000	2.30	1850	7/8	3/8	7/8	3/8	1-1/8	3/8	NA	H4TXV02
	E(C,H,M,U)1P62C	13.00	11.00	58,000	41180	7.70	55000	3.30	34000	2.30	1850	7/8	3/8	7/8	3/8	1-1/8	3/8	NA	H4TXV02
	E(C,H,M,U)1P62D	13.00	11.00	58,000	41180	7.70	55000	3.30	34000	2.30	1850	7/8	3/8	7/8	3/8	1-1/8	3/8	NA	H4TXV02

Note: ¹ Certified in accordance with Unitary Air Conditioner Certification Program, which is based on AHRI Standard 210/240.
² Required to achieve AHRI rating. If NA (Not Applicable) is in the piston column, then TXV is required.
³ A blower time delay relay is standard on all Allied Air Enterprises furnaces and AH products.

Cooling Performance with Air Handlers and Furnaces 18

Outdoor Model	Indoor Model		Cooling				Heating				CFM	Refrigerant Connection				Refrig. Line Size		Indoor Expansion Device		
			SEER	EER	ARI Rated Capacity ¹	Sensible Capacity	HSPF	47		17		Outdoor		Indoor		Suction	Liquid	Piston ²	TXV	
	Btuh	COP						Btuh	COP	Suction		Liquid	Suction	Liquid						
	Evaporator Coil or Air Handler ₃	Furnaces																		
4HP13L18P-7	BCS2M18C****P		13.0	11.0	18,000	12,780	7.7	17,000	3.2	10,000	2.00	650	3/4	3/8	3/4	3/8	3/4	3/8	NA	H4TXV01
	BCS2M24V****P		14.0	11.0	18,000	12,780	7.7	17,000	3.2	10,000	2.00	650	3/4	3/8	3/4	3/8	3/4	3/8	NA	H4TXV01
	BCS3M18C****P		13.0	11.0	18,000	12,780	7.7	17,000	3.2	10,000	2.00	650	3/4	3/8	3/4	3/8	3/4	3/8	NA	H4TXV01
	E(C,H,M,U)1P18A	A80DF1E045A12	13.5	11.0	18,000	12,780	7.7	17,000	3.2	10,000	2.00	650	3/4	3/8	3/4	3/8	3/4	3/8	NA	H4TXV01
	E(C,H,M,U)1P24A	A80DF1E045A12	13.5	11.0	18,000	12,780	7.7	17,000	3.2	10,000	2.00	650	3/4	3/8	3/4	3/8	3/4	3/8	NA	H4TXV01
	E(C,H,M,U)1P18B	A80DF1E070B12	13.5	11.0	18,000	12,780	7.7	17,000	3.2	10,000	2.00	650	3/4	3/8	3/4	3/8	3/4	3/8	NA	H4TXV01
	E(C,H,M,U)1P24B	A80DF1E070B12	13.5	11.0	18,000	12,780	7.7	17,000	3.2	10,000	2.00	650	3/4	3/8	3/4	3/8	3/4	3/8	NA	H4TXV01
	E(C,H,M,U)1P18A	A80UH1E045A12*	13.5	11.0	18,000	12,780	7.7	17,000	3.2	10,000	2.00	650	3/4	3/8	3/4	3/8	3/4	3/8	NA	H4TXV01
	E(C,H,M,U)1P24A	A80UH1E045A12*	13.5	11.0	18,000	12,780	7.7	17,000	3.2	10,000	2.00	650	3/4	3/8	3/4	3/8	3/4	3/8	NA	H4TXV01
	E(C,H,M,U)1P18B	A80UH1E070B12*	13.5	11.0	18,000	12,780	7.7	17,000	3.2	10,000	2.00	650	3/4	3/8	3/4	3/8	3/4	3/8	NA	H4TXV01
	E(C,H,M,U)1P24B	A80UH1E070B12*	13.5	11.0	18,000	12,780	7.7	17,000	3.2	10,000	2.00	650	3/4	3/8	3/4	3/8	3/4	3/8	NA	H4TXV01
	E(C,H,M,U)1P18A	A80UH2V070A12*	13.5	11.0	18,000	12,780	7.7	17,000	3.2	10,000	2.00	650	3/4	3/8	3/4	3/8	3/4	3/8	NA	H4TXV01
	E(C,H,M,U)1P24A	A80UH2V070A12*	14.0	11.0	18,000	12,780	7.7	17,000	3.2	10,000	2.00	650	3/4	3/8	3/4	3/8	3/4	3/8	NA	H4TXV01
	E(C,H,M,U)1P18B	A80UH2V090B16*	13.5	11.0	18,000	12,780	7.7	17,000	3.2	10,000	2.00	650	3/4	3/8	3/4	3/8	3/4	3/8	NA	H4TXV01
	E(C,H,M,U)1P24B	A80UH2V090B16*	14.0	11.0	18,000	12,780	7.7	17,000	3.2	10,000	2.00	650	3/4	3/8	3/4	3/8	3/4	3/8	NA	H4TXV01
	E(C,H,M,U)1P18B	A95DF1E045B12S	13.5	11.0	18,000	12,780	7.7	17,000	3.2	10,000	2.00	650	3/4	3/8	3/4	3/8	3/4	3/8	NA	H4TXV01
	E(C,H,M,U)1P24B	A95DF1E045B12S	13.5	11.0	18,000	12,780	7.7	17,000	3.2	10,000	2.00	650	3/4	3/8	3/4	3/8	3/4	3/8	NA	H4TXV01
	E(C,H,M,U)1P18B	A95DF2V045B12S	13.5	11.0	18,000	12,780	7.7	17,000	3.2	10,000	2.00	650	3/4	3/8	3/4	3/8	3/4	3/8	NA	H4TXV01
	E(C,H,M,U)1P24B	A95DF2V045B12S	13.5	11.0	18,000	12,780	7.7	17,000	3.2	10,000	2.00	650	3/4	3/8	3/4	3/8	3/4	3/8	NA	H4TXV01
	E(C,H,M,U)1P18B	A95DF2V070B16S	14.0	11.0	18,000	12,780	7.7	17,000	3.2	10,000	2.00	650	3/4	3/8	3/4	3/8	3/4	3/8	NA	H4TXV01
	E(C,H,M,U)1P24B	A95DF2V070B16S	14.0	11.0	18,000	12,780	7.7	17,000	3.2	10,000	2.00	650	3/4	3/8	3/4	3/8	3/4	3/8	NA	H4TXV01
	E(C,H,M,U)1P18B	A95UH1E045B12S	13.5	11.0	18,000	12,780	7.7	17,000	3.2	10,000	2.00	650	3/4	3/8	3/4	3/8	3/4	3/8	NA	H4TXV01
	E(C,H,M,U)1P24B	A95UH1E045B12S	13.5	11.0	18,000	12,780	7.7	17,000	3.2	10,000	2.00	650	3/4	3/8	3/4	3/8	3/4	3/8	NA	H4TXV01
	E(C,H,M,U)1P18B	A95UH1E070B12S	13.5	11.0	18,000	12,780	7.7	17,000	3.2	10,000	2.00	650	3/4	3/8	3/4	3/8	3/4	3/8	NA	H4TXV01

Note:

¹ Certified in accordance with Unitary Air Conditioner Certification Program, which is based on AHRI Standard 210/240.

² Required to achieve AHRI rating. If NA (Not Applicable) is in the piston column, then TXV is required.

³ A blower time delay relay is standard on all Allied Air Enterprises furnaces and AH products.

Cooling Performance with Air Handlers and Furnaces 18, 24

Outdoor Model	Indoor Model		Cooling				Heating				CFM	Refrigerant Connection				Refrig. Line Size		Indoor Expansion Device		
			Evaporator Coil or Air Handler ³	Furnaces	SEER	EER	ARI Rated Capacity ¹	Sensible Capacity	HSPF	47		17		Outdoor		Indoor		Suction	Liquid	Piston ²
	Btuh	COP								Btuh		COP	Suction	Liquid	Suction	Liquid				
4HP13L18P-7	E(C,H,M,U)1P24B	A95UH1E070B12S	13.5	11.0	18,000	12,780	7.7	17,000	3.2	10,000	2.00	650	3/4	3/8	3/4	3/8	3/4	3/8	NA	H4TXV01
	E(C,H,M,U)1P18B	A95UH2V045B12S	14.0	11.0	18,000	12,780	7.7	17,000	3.2	10,000	2.00	650	3/4	3/8	3/4	3/8	3/4	3/8	NA	H4TXV01
	E(C,H,M,U)1P24B	A95UH2V045B12S	14.0	11.0	18,000	12,780	7.7	17,000	3.2	10,000	2.00	650	3/4	3/8	3/4	3/8	3/4	3/8	NA	H4TXV01
	E(C,H,M,U)1P18B	A95UH2V070B12S	14.0	11.0	18,000	12,780	7.7	17,000	3.2	10,000	2.00	650	3/4	3/8	3/4	3/8	3/4	3/8	NA	H4TXV01
	E(C,H,M,U)1P24B	A95UH2V070B12S	14.0	11.0	18,000	12,780	7.7	17,000	3.2	10,000	2.00	650	3/4	3/8	3/4	3/8	3/4	3/8	NA	H4TXV01
4HP13L24P-7	BCS2M24C****P		13.0	11.0	23,000	16,790	7.7	21,600	3.3	13,000	2.20	850	3/4	3/8	3/4	3/8	3/4	3/8	.057	H4TXV01
	BCS2M24V****P		13.0	11.0	23,000	16,790	7.7	21,600	3.3	13,000	2.20	850	3/4	3/8	3/4	3/8	3/4	3/8	.057	H4TXV01
	BCS3M24C****P		13.0	11.0	23,000	16,790	7.7	21,600	3.3	13,000	2.20	850	3/4	3/8	3/4	3/8	3/4	3/8	.057	H4TXV01
	E(C,H,M,U)1P23A	A80DF1E045A12	14.0	11.0	23,000	16,790	7.7	21,600	3.3	13,000	2.20	850	3/4	3/8	3/4	3/8	3/4	3/8	.057	H4TXV01
	E(C,H,M,U)1P24A	A80DF1E045A12	14.0	11.0	23,000	16,790	7.7	21,600	3.3	13,000	2.20	850	3/4	3/8	3/4	3/8	3/4	3/8	.057	H4TXV01
	E(C,H,M,U)1P23B	A80DF1E070B12	14.0	11.0	23,000	16,790	7.7	21,600	3.3	13,000	2.20	850	3/4	3/8	3/4	3/8	3/4	3/8	.057	H4TXV01
	E(C,H,M,U)1P24B	A80DF1E070B12	14.0	11.0	23,000	16,790	7.7	21,600	3.3	13,000	2.20	850	3/4	3/8	3/4	3/8	3/4	3/8	.057	H4TXV01
	E(C,H,M,U)1P23A	A80UH1E045A12*	13.5	11.0	23,000	16,790	7.7	21,600	3.3	13,000	2.20	850	3/4	3/8	3/4	3/8	3/4	3/8	.057	H4TXV01
	E(C,H,M,U)1P24A	A80UH1E045A12*	14.0	11.0	23,000	16,790	7.7	21,600	3.3	13,000	2.20	850	3/4	3/8	3/4	3/8	3/4	3/8	.057	H4TXV01
	E(C,H,M,U)1P23B	A80UH1E070B12*	14.0	11.0	23,000	16,790	7.7	21,600	3.3	13,000	2.20	850	3/4	3/8	3/4	3/8	3/4	3/8	.057	H4TXV01
	E(C,H,M,U)1P24B	A80UH1E070B12*	14.0	11.0	23,000	16,790	7.7	21,600	3.3	13,000	2.20	850	3/4	3/8	3/4	3/8	3/4	3/8	.057	H4TXV01
	E(C,H,M,U)1P23A	A80UH2V070A12*	14.0	11.0	23,000	16,790	7.7	21,400	3.3	13,000	2.20	850	3/4	3/8	3/4	3/8	3/4	3/8	.057	H4TXV01
	E(C,H,M,U)1P24A	A80UH2V070A12*	14.0	11.0	23,000	16,790	7.7	21,200	3.3	13,000	2.20	850	3/4	3/8	3/4	3/8	3/4	3/8	.057	H4TXV01
	E(C,H,M,U)1P23B	A80UH2V090B16*	13.5	11.0	23,000	16,790	7.7	21,400	3.3	13,000	2.20	850	3/4	3/8	3/4	3/8	3/4	3/8	.057	H4TXV01
	E(C,H,M,U)1P24B	A80UH2V090B16*	13.5	11.0	23,000	16,790	7.7	21,400	3.3	13,000	2.20	850	3/4	3/8	3/4	3/8	3/4	3/8	.057	H4TXV01
	E(C,H,M,U)1P23B	A95DF1E045B12S	13.5	11.0	23,000	16,790	7.7	21,600	3.3	13,000	2.20	850	3/4	3/8	3/4	3/8	3/4	3/8	.057	H4TXV01
	E(C,H,M,U)1P24B	A95DF1E045B12S	14.0	11.0	23,000	16,790	7.7	21,600	3.3	13,000	2.20	850	3/4	3/8	3/4	3/8	3/4	3/8	.057	H4TXV01
	E(C,H,M,U)1P23B	A95DF2V045B12S	14.0	11.0	23,000	16,790	7.7	21,600	3.3	13,000	2.20	850	3/4	3/8	3/4	3/8	3/4	3/8	.057	H4TXV01
	E(C,H,M,U)1P24B	A95DF2V045B12S	14.0	11.0	23,000	16,790	7.7	21,600	3.3	13,000	2.20	850	3/4	3/8	3/4	3/8	3/4	3/8	.057	H4TXV01

Note:

¹ Certified in accordance with Unitary Air Conditioner Certification Program, which is based on AHRI Standard 210/240.

² Required to achieve AHRI rating. If NA (Not Applicable) is in the piston column, then TXV is required.

³ A blower time delay relay is standard on all Allied Air Enterprises furnaces and AH products.

Cooling Performance with Air Handlers and Furnaces 24, 30

Outdoor Model	Indoor Model		Cooling				Heating				CFM	Refrigerant Connection				Refrig. Line Size		Indoor Expansion Device		
												Outdoor		Indoor		Suction	Liquid	Piston ²	TXV	
	Evaporator Coil or Air Handler ³	Furnaces	SEER	EER	ARI Rated Capacity ¹	Sensible Capacity	HSPF	47		17		Suction	Liquid	Suction	Liquid					
								Btuh	COP	Btuh						COP				
4HP13L24P-7	E(C,H,M,U)1P23B	A95DF2V070B16S	14.0	11.0	23,000	16,790	7.7	21,600	3.3	13,000	2.20	850	3/4	3/8	3/4	3/8	3/4	3/8	.057	H4TXV01
	E(C,H,M,U)1P24B	A95DF2V070B16S	14.0	11.0	23,000	16,790	7.7	21,600	3.3	13,000	2.20	850	3/4	3/8	3/4	3/8	3/4	3/8	.057	H4TXV01
	E(C,H,M,U)1P23B	A95UH1E045B12S	13.5	11.0	23,000	16,790	7.7	21,600	3.3	13,000	2.20	850	3/4	3/8	3/4	3/8	3/4	3/8	.057	H4TXV01
	E(C,H,M,U)1P24B	A95UH1E045B12S	14.0	11.0	23,000	16,790	7.7	21,600	3.3	13,000	2.20	850	3/4	3/8	3/4	3/8	3/4	3/8	.057	H4TXV01
	E(C,H,M,U)1P23B	A95UH1E070B12S	13.5	11.0	23,000	16,790	7.7	21,600	3.3	13,000	2.20	850	3/4	3/8	3/4	3/8	3/4	3/8	.057	H4TXV01
	E(C,H,M,U)1P24B	A95UH1E070B12S	14.0	11.0	23,000	16,790	7.7	21,600	3.3	13,000	2.20	850	3/4	3/8	3/4	3/8	3/4	3/8	.057	H4TXV01
	E(C,H,M,U)1P23B	A95UH2V045B12S	14.0	11.0	23,000	16,790	7.7	21,600	3.3	13,000	2.20	850	3/4	3/8	3/4	3/8	3/4	3/8	.057	H4TXV01
	E(C,H,M,U)1P24B	A95UH2V045B12S	14.0	11.0	23,000	16,790	7.7	21,600	3.3	13,000	2.20	850	3/4	3/8	3/4	3/8	3/4	3/8	.057	H4TXV01
	E(C,H,M,U)1P23B	A95UH2V070B12S	14.0	11.0	23,000	16,790	7.7	21,600	3.3	13,000	2.20	850	3/4	3/8	3/4	3/8	3/4	3/8	.057	H4TXV01
	E(C,H,M,U)1P24B	A95UH2V070B12S	14.0	11.0	23,000	16,790	7.7	21,600	3.3	13,000	2.20	850	3/4	3/8	3/4	3/8	3/4	3/8	.057	H4TXV01
4HP13L30P-7	BCS2M30C****P		13.0	11.0	29,000	21,460	7.7	27,000	3.4	17,000	2.20	1,000	3/4	3/8	7/8	3/8	3/4	3/8	.062	H4TXV01
	BCS2M36V****P		14.0	11.0	29,000	21,460	7.7	27,000	3.4	17,000	2.20	1,000	3/4	3/8	7/8	3/8	3/4	3/8	.062	H4TXV01
	BCS3M30C****P		13.0	11.0	29,000	21,460	7.7	27,000	3.4	17,000	2.20	1,000	3/4	3/8	7/8	3/8	3/4	3/8	.062	H4TXV01
	E(C,H,M,U)1P29A	A80DF1E045A12	13.5	11.0	29,000	21,460	7.7	27,000	3.4	17,000	2.20	1,000	3/4	3/8	3/4	3/8	3/4	3/8	.062	H4TXV01
	E(C,H,M,U)1P29B	A80DF1E070B12	14.0	11.0	29,000	21,460	7.7	26,800	3.4	16,800	2.20	1,000	3/4	3/8	3/4	3/8	3/4	3/8	.062	H4TXV01
	E(C,H,M,U)1P29B	A80DF1E090B16	14.0	11.0	29,000	21,460	7.7	26,800	3.4	16,800	2.20	1,000	3/4	3/8	3/4	3/8	3/4	3/8	.062	H4TXV01
	E(C,H,M,U)1P29A	A80UH1E045A12*	14.0	11.0	29,000	21,460	7.7	27,000	3.4	17,000	2.20	1,000	3/4	3/8	3/4	3/8	3/4	3/8	.062	H4TXV01
	E(C,H,M,U)1P29B	A80UH1E070B12*	14.0	11.0	29,000	21,460	7.7	26,800	3.4	16,800	2.20	1,000	3/4	3/8	3/4	3/8	3/4	3/8	.062	H4TXV01
	E(C,H,M,U)1P29B	A80UH1E090B16*	14.0	11.0	29,000	21,460	7.7	26,800	3.4	16,800	2.20	1,000	3/4	3/8	3/4	3/8	3/4	3/8	.062	H4TXV01
	E(C,H,M,U)1P29A	A80UH2V070A12*	13.5	11.0	29,000	21,460	7.7	27,000	3.4	16,800	2.20	1,000	3/4	3/8	3/4	3/8	3/4	3/8	.062	H4TXV01
	E(C,H,M,U)1P29B	A80UH2V090B16*	13.5	11.0	29,000	21,460	7.7	27,000	3.4	17,000	2.20	1,000	3/4	3/8	3/4	3/8	3/4	3/8	.062	H4TXV01
	E(C,H,M,U)1P29B	A95DF1E045B12S	13.5	11.0	29,000	21,460	7.7	27,000	3.4	17,000	2.20	1,000	3/4	3/8	3/4	3/8	3/4	3/8	.062	H4TXV01
	E(C,H,M,U)1P29B	A95DF1E070B16S	14.0	11.0	29,000	21,460	7.7	27,000	3.4	17,000	2.20	1,000	3/4	3/8	3/4	3/8	3/4	3/8	.062	H4TXV01
	E(C,H,M,U)1P29B	A95DF2V045B12S	14.0	11.0	29,000	21,460	7.7	27,000	3.4	16,800	2.20	1,000	3/4	3/8	3/4	3/8	3/4	3/8	.062	H4TXV01

Note:

¹ Certified in accordance with Unitary Air Conditioner Certification Program, which is based on AHRI Standard 210/240.

² Required to achieve AHRI rating. If NA (Not Applicable) is in the piston column, then TXV is required.

³ A blower time delay relay is standard on all Allied Air Enterprises furnaces and AH products.

Cooling Performance with Air Handlers and Furnaces 30, 36

Outdoor Model	Indoor Model		Cooling				Heating				CFM	Refrigerant Connection				Refrig. Line Size		Indoor Expansion Device		
			Evaporator Coil or Air Handler ₃	Furnaces	SEER	EER	ARI Rated Capacity ¹	Sensible Capacity	HSPF	47		17		Outdoor		Indoor		Suction	Liquid	Piston ²
	Btuh	COP								Btuh		COP	Suction	Liquid	Suction	Liquid				
45HP13L30P-7	E(C,H,M,U)1P29B	A95DF2V070B16S	13.5	11.0	29,000	21,460	7.7	27,000	3.4	17,000	2.20	1,000	3/4	3/8	3/4	3/8	3/4	3/8	.062	H4TXV01
	E(C,H,M,U)1P29B	A95UH1E045B12S	13.5	11.0	29,000	21,460	7.7	27,000	3.4	17,000	2.20	1,000	3/4	3/8	3/4	3/8	3/4	3/8	.062	H4TXV01
	E(C,H,M,U)1P29B	A95UH1E070B12S	13.5	11.0	29,000	21,460	7.7	27,000	3.4	17,000	2.20	1,000	3/4	3/8	3/4	3/8	3/4	3/8	.062	H4TXV01
	E(C,H,M,U)1P29B	A95UH2V045B12S	13.5	11.0	29,000	21,460	7.7	27,000	3.4	17,000	2.20	1,000	3/4	3/8	3/4	3/8	3/4	3/8	.062	H4TXV01
	E(C,H,M,U)1P29B	A95UH2V070B12S	14.0	11.0	29,000	21,460	7.7	27,000	3.4	16,800	2.20	1,000	3/4	3/8	3/4	3/8	3/4	3/8	.062	H4TXV01
45HP13L30P-7	BCS2M36C****P		13.0	11.0	35,000	25,200	7.7	33,800	3.4	18,000	2.20	1,275	3/4	3/8	7/8	3/8	3/4	3/8	.071	H4TXV01
	BCS2M36V****P		14.0	11.0	35,000	25,200	7.7	33,800	3.4	18,000	2.20	1,275	3/4	3/8	7/8	3/8	3/4	3/8	.071	H4TXV01
	BCS3M36C****P		13.0	11.0	35,000	25,200	7.7	33,800	3.4	18,000	2.20	1,275	3/4	3/8	7/8	3/8	3/4	3/8	.071	H4TXV01
	E(C,H,M,U)1P30A	A80DF1E045A12	13.5	11.0	35,000	25,200	7.7	32,800	3.4	18,000	2.20	1,275	3/4	3/8	3/4	3/8	3/4	3/8	.071	H4TXV01
	E(C,H,M,U)1P36A	A80DF1E045A12	14.0	11.0	35,000	25,200	7.7	33,000	3.4	18,000	2.20	1,275	3/4	3/8	3/4	3/8	3/4	3/8	.071	H4TXV01
	E(C,H,M,U)1P30B	A80DF1E070B12	13.5	11.0	35,000	25,200	7.7	32,800	3.4	18,000	2.20	1,275	3/4	3/8	3/4	3/8	3/4	3/8	.071	H4TXV01
	E(C,H,M,U)1P36B	A80DF1E070B12	14.0	11.0	35,000	25,200	7.7	33,000	3.4	18,000	2.20	1,275	3/4	3/8	3/4	3/8	3/4	3/8	.071	H4TXV01
	E(C,H,M,U)1P30B	A80DF1E090B16	13.5	11.0	35,000	25,200	7.7	32,800	3.4	18,000	2.20	1,275	3/4	3/8	3/4	3/8	3/4	3/8	.071	H4TXV01
	E(C,H,M,U)1P36B	A80DF1E090B16	13.5	11.0	35,000	25,200	7.7	33,000	3.4	18,000	2.20	1,275	3/4	3/8	3/4	3/8	3/4	3/8	.071	H4TXV01
	E(C,H,M,U)1P30C	A80DF1E110C20	13.5	11.0	35,000	25,200	7.7	32,800	3.4	18,000	2.20	1,275	3/4	3/8	3/4	3/8	3/4	3/8	.071	H4TXV01
	E(C,H,M,U)1P36C	A80DF1E110C20	14.0	11.0	35,000	25,200	7.7	33,000	3.4	18,000	2.20	1,275	3/4	3/8	3/4	3/8	3/4	3/8	.071	H4TXV01
	E(C,H,M,U)1P30B	A80UH1E070B12*	13.5	11.0	35,000	25,200	7.7	32,800	3.4	18,000	2.20	1,275	3/4	3/8	3/4	3/8	3/4	3/8	.071	H4TXV01
	E(C,H,M,U)1P36B	A80UH1E070B12*	14.0	11.0	35,000	25,200	7.7	33,000	3.4	18,000	2.20	1,275	3/4	3/8	3/4	3/8	3/4	3/8	.071	H4TXV01
	E(C,H,M,U)1P30B	A80UH1E090B16*	14.0	11.0	35,000	25,200	7.7	32,800	3.4	18,000	2.20	1,275	3/4	3/8	3/4	3/8	3/4	3/8	.071	H4TXV01
	E(C,H,M,U)1P36B	A80UH1E090B16*	14.0	11.0	35,000	25,200	7.7	33,000	3.4	18,000	2.20	1,275	3/4	3/8	3/4	3/8	3/4	3/8	.071	H4TXV01
	E(C,H,M,U)1P30C	A80UH1E090C20*	13.5	11.0	35,000	25,200	7.7	32,800	3.4	18,000	2.20	1,275	3/4	3/8	3/4	3/8	3/4	3/8	.071	H4TXV01
	E(C,H,M,U)1P36C	A80UH1E090C20*	14.0	11.0	35,000	25,200	7.7	33,000	3.4	18,000	2.20	1,275	3/4	3/8	3/4	3/8	3/4	3/8	.071	H4TXV01
	E(C,H,M,U)1P30C	A80UH1E110C20*	13.5	11.0	35,000	25,200	7.7	32,800	3.4	18,000	2.20	1,275	3/4	3/8	3/4	3/8	3/4	3/8	.071	H4TXV01
	E(C,H,M,U)1P36C	A80UH1E110C20*	14.0	11.0	35,000	25,200	7.7	33,000	3.4	18,000	2.20	1,275	3/4	3/8	3/4	3/8	3/4	3/8	.071	H4TXV01

Note:

¹ Certified in accordance with Unitary Air Conditioner Certification Program, which is based on AHRI Standard 210/240.

² Required to achieve AHRI rating. If NA (Not Applicable) is in the piston column, then TXV is required.

³ A blower time delay relay is standard on all Allied Air Enterprises furnaces and AH products.

Cooling Performance with Air Handlers and Furnaces 36

Outdoor Model	Indoor Model		Cooling				Heating				CFM	Refrigerant Connection				Refrig. Line Size		Indoor Expansion Device		
			SEER	EER	ARI Rated Capacity ¹	Sensible Capacity	HSPF	47		17		Outdoor		Indoor		Suction	Liquid	Piston ²	TXV	
	Btuh	COP						Btuh	COP	Suction		Liquid	Suction	Liquid						
	Evaporator Coil or Air Handler ₃	Furnaces																		
4HP13L36P-7	E(C,H,M,U)1P30B	A80UH2V090B16*	13.5	11.0	35,000	25,200	7.7	32,800	3.4	18,000	2.20	1,275	3/4	3/8	3/4	3/8	3/4	3/8	.071	H4TXV01
	E(C,H,M,U)1P36B	A80UH2V090B16*	13.5	11.0	35,000	25,200	7.7	32,800	3.4	18,000	2.20	1,275	3/4	3/8	3/4	3/8	3/4	3/8	.071	H4TXV01
	E(C,H,M,U)1P30C	A80UH2V110C20*	13.5	11.0	35,000	25,200	7.7	32,800	3.4	18,000	2.20	1,275	3/4	3/8	3/4	3/8	3/4	3/8	.071	H4TXV01
	E(C,H,M,U)1P36C	A80UH2V110C20*	14.0	11.0	35,000	25,200	7.7	32,800	3.4	18,000	2.20	1,275	3/4	3/8	3/4	3/8	3/4	3/8	.071	H4TXV01
	E(C,H,M,U)1P36B	A95DF1E070B16S	13.5	11.0	35,000	25,200	7.7	33,000	3.4	18,000	2.20	1,275	3/4	3/8	3/4	3/8	3/4	3/8	.071	H4TXV01
	E(C,H,M,U)1P30C	A95DF1E090C16S	13.5	11.0	35,000	25,200	7.7	32,800	3.4	18,000	2.20	1,275	3/4	3/8	3/4	3/8	3/4	3/8	.071	H4TXV01
	E(C,H,M,U)1P36C	A95DF1E090C16S	14.0	11.0	35,000	25,200	7.7	33,000	3.4	18,000	2.20	1,275	3/4	3/8	3/4	3/8	3/4	3/8	.071	H4TXV01
	E(C,H,M,U)1P30C	A95DF1E110C20S	13.5	11.0	35,000	25,200	7.7	32,800	3.4	18,000	2.20	1,275	3/4	3/8	3/4	3/8	3/4	3/8	.071	H4TXV01
	E(C,H,M,U)1P36C	A95DF1E110C20S	13.5	11.0	35,000	25,200	7.7	33,000	3.4	18,000	2.20	1,275	3/4	3/8	3/4	3/8	3/4	3/8	.071	H4TXV01
	E(C,H,M,U)1P30B	A95DF2V045B12S	13.5	11.0	35,000	25,200	7.7	32,800	3.4	18,000	2.20	1,275	3/4	3/8	3/4	3/8	3/4	3/8	.071	H4TXV01
	E(C,H,M,U)1P36B	A95DF2V045B12S	13.5	11.0	35,000	25,200	7.7	33,000	3.4	18,000	2.20	1,275	3/4	3/8	3/4	3/8	3/4	3/8	.071	H4TXV01
	E(C,H,M,U)1P30B	A95DF2V070B16S	13.5	11.0	35,000	25,200	7.7	32,800	3.4	18,000	2.20	1,275	3/4	3/8	3/4	3/8	3/4	3/8	.071	H4TXV01
	E(C,H,M,U)1P36B	A95DF2V070B16S	13.5	11.0	35,000	25,200	7.7	33,000	3.4	18,000	2.20	1,275	3/4	3/8	3/4	3/8	3/4	3/8	.071	H4TXV01
	E(C,H,M,U)1P30C	A95DF2V090C20S	14.0	11.0	35,000	25,200	7.7	32,800	3.4	18,000	2.20	1,275	3/4	3/8	3/4	3/8	3/4	3/8	.071	H4TXV01
	E(C,H,M,U)1P36C	A95DF2V090C20S	14.0	11.0	35,000	25,200	7.7	33,000	3.4	18,000	2.20	1,275	3/4	3/8	3/4	3/8	3/4	3/8	.071	H4TXV01
	E(C,H,M,U)1P30C	A95DF2V110C20S	14.0	11.0	35,000	25,200	7.7	32,800	3.4	18,000	2.20	1,275	3/4	3/8	3/4	3/8	3/4	3/8	.071	H4TXV01
	E(C,H,M,U)1P36C	A95DF2V110C20S	14.0	11.0	35,000	25,200	7.7	33,000	3.4	18,000	2.20	1,275	3/4	3/8	3/4	3/8	3/4	3/8	.071	H4TXV01
	E(C,H,M,U)1P30C	A95UH1E090C16S	13.5	11.0	35,000	25,200	7.7	32,800	3.4	18,000	2.20	1,275	3/4	3/8	3/4	3/8	3/4	3/8	.071	H4TXV01
	E(C,H,M,U)1P36C	A95UH1E090C16S	14.0	11.0	35,000	25,200	7.7	33,000	3.4	18,000	2.20	1,275	3/4	3/8	3/4	3/8	3/4	3/8	.071	H4TXV01
	E(C,H,M,U)1P30C	A95UH1E110C20S	13.5	11.0	35,000	25,200	7.7	32,800	3.4	18,000	2.20	1,275	3/4	3/8	3/4	3/8	3/4	3/8	.071	H4TXV01
E(C,H,M,U)1P36C	A95UH1E110C20S	13.5	11.0	35,000	25,200	7.7	33,000	3.4	18,000	2.20	1,275	3/4	3/8	3/4	3/8	3/4	3/8	.071	H4TXV01	
E(C,H,M,U)1P30B	A95UH2V045B12S	13.5	11.0	35,000	25,200	7.7	32,800	3.4	18,000	2.20	1,275	3/4	3/8	3/4	3/8	3/4	3/8	.071	H4TXV01	
E(C,H,M,U)1P36B	A95UH2V045B12S	13.5	11.0	35,000	25,200	7.7	33,000	3.4	18,000	2.20	1,275	3/4	3/8	3/4	3/8	3/4	3/8	.071	H4TXV01	
E(C,H,M,U)1P30B	A95UH2V070B12S	13.5	11.0	35,000	25,200	7.7	32,800	3.4	18,000	2.20	1,275	3/4	3/8	3/4	3/8	3/4	3/8	.071	H4TXV01	

Note:

¹ Certified in accordance with Unitary Air Conditioner Certification Program, which is based on AHRI Standard 210/240.

² Required to achieve AHRI rating. If NA (Not Applicable) is in the piston column, then TXV is required.

³ A blower time delay relay is standard on all Allied Air Enterprises furnaces and AH products.

Cooling Performance with Air Handlers and Furnaces 36, 42

Outdoor Model	Indoor Model		Cooling				Heating				CFM	Refrigerant Connection				Refrig. Line Size		Indoor Expansion Device		
			Evaporator Coil or Air Handler ₃	Furnaces	SEER	EER	ARI Rated Capacity ¹	Sensible Capacity	HSPF	47		17		Outdoor		Indoor		Suction	Liquid	Piston ²
	Btuh	COP								Btuh		COP	Suction	Liquid	Suction	Liquid				
4HP13L36P-7	E(C,H,M,U)1P36B	A95UH2V070B12S	14.0	11.0	35,000	25,200	7.7	33,000	3.4	18,000	2.20	1,275	3/4	3/8	3/4	3/8	3/4	3/8	.071	H4TXV01
	E(C,H,M,U)1P30C	A95UH2V090C12S	14.0	11.0	35,000	25,200	7.7	32,800	3.4	18,000	2.20	1,275	3/4	3/8	3/4	3/8	3/4	3/8	.071	H4TXV01
	E(C,H,M,U)1P36C	A95UH2V090C12S	14.0	11.0	35,000	25,200	7.7	33,000	3.4	18,000	2.20	1,275	3/4	3/8	3/4	3/8	3/4	3/8	.071	H4TXV01
	E(C,H,M,U)1P30C	A95UH2V090C20S	14.0	11.0	35,000	25,200	7.7	32,800	3.4	18,000	2.20	1,275	3/4	3/8	3/4	3/8	3/4	3/8	.071	H4TXV01
	E(C,H,M,U)1P36C	A95UH2V090C20S	14.0	11.0	35,000	25,200	7.7	33,000	3.4	18,000	2.20	1,275	3/4	3/8	3/4	3/8	3/4	3/8	.071	H4TXV01
	E(C,H,M,U)1P30C	A95UH2V110C20S	14.0	11.0	35,000	25,200	7.7	32,800	3.4	18,000	2.20	1,275	3/4	3/8	3/4	3/8	3/4	3/8	.071	H4TXV01
	E(C,H,M,U)1P36C	A95UH2V110C20S	14.0	11.0	35,000	25,200	7.7	33,000	3.4	18,000	2.20	1,275	3/4	3/8	3/4	3/8	3/4	3/8	.071	H4TXV01
4HP13L36P-7	BCS2M42C****P		13.0	11.0	41,000	29,520	7.7	40,000	3.5	25,000	2.20	1,400	7/8	3/8	7/8	3/8	7/8	3/8	.076	H4TXV02
	BCS2M42V****P		13.0	11.0	41,000	29,520	7.7	40,000	3.5	25,000	2.20	1,400	7/8	3/8	7/8	3/8	7/8	3/8	.076	H4TXV02
	BCS3M42C****P		13.0	11.0	41,000	29,520	7.7	40,000	3.5	25,000	2.20	1,400	7/8	3/8	7/8	3/8	7/8	3/8	.076	H4TXV02
	E(C,H,M,U)1P36C	A80DF1E110C20	13.5	11.0	41,000	29,520	7.7	40,000	3.4	25,000	2.30	1,400	7/8	3/8	7/8	3/8	7/8	3/8	.076	H4TXV02
	E(C,H,M,U)1P36B	A80UH1E090B16*	13.5	11.0	41,000	29,520	7.7	40,000	3.4	25,000	2.30	1,400	7/8	3/8	7/8	3/8	7/8	3/8	.076	H4TXV02
	E(C,H,M,U)1P43B	A80UH1E090B16*	13.5	11.0	41,000	29,520	7.7	39,500	3.4	25,000	2.30	1,400	7/8	3/8	7/8	3/8	7/8	3/8	.076	H4TXV02
	E(C,H,M,U)1P36C	A80UH1E090C20*	13.5	11.0	41,000	29,520	7.7	40,000	3.4	25,000	2.30	1,400	7/8	3/8	7/8	3/8	7/8	3/8	.076	H4TXV02
	E(C,H,M,U)1P36C	A80UH1E110C20*	13.5	11.0	41,000	29,520	7.7	40,000	3.4	25,000	2.30	1,400	7/8	3/8	7/8	3/8	7/8	3/8	.076	H4TXV02
	E(C,H,M,U)1P36C	A95DF1E110C20S	13.5	11.0	41,000	29,520	7.7	40,000	3.4	25,000	2.30	1,400	7/8	3/8	7/8	3/8	7/8	3/8	.076	H4TXV02
	E(C,H,M,U)1P43C	A95DF1E110C20S	13.5	11.0	41,000	29,520	7.7	39,500	3.4	25,000	2.30	1,400	7/8	3/8	7/8	3/8	7/8	3/8	.076	H4TXV02

Note:

¹ Certified in accordance with Unitary Air Conditioner Certification Program, which is based on AHRI Standard 210/240.

² Required to achieve AHRI rating. If NA (Not Applicable) is in the piston column, then TXV is required.

³ A blower time delay relay is standard on all Allied Air Enterprises furnaces and AH products.

Cooling Performance with Air Handlers and Furnaces 42, 48 and 60

Outdoor Model	Indoor Model		Cooling				Heating				CFM	Refrigerant Connection				Refrig. Line Size		Indoor Expansion Device		
												Outdoor		Indoor		Suction	Liquid	Piston ²	TXV	
	Evaporator Coil or Air Handler ₃	Furnaces	SEER	EER	ARI Rated Capacity ¹	Sensible Capacity	HSPF	47		17		Suction	Liquid	Suction	Liquid					
								Btuh	COP	Btuh						COP				
4HP13L42P-7	E(C,H,M,U)1P36C	A95DF2V090C20S	13.5	11.0	41,000	29,520	7.7	40,000	3.4	25,000	2.30	1,400	7/8	3/8	7/8	3/8	7/8	3/8	.076	H4TXV02
	E(C,H,M,U)1P36C	A95DF2V110C20S	13.5	11.0	41,000	29,520	7.7	40,000	3.4	25,000	2.30	1,400	7/8	3/8	7/8	3/8	7/8	3/8	.076	H4TXV02
	E(C,H,M,U)1P43C	A95DF2V110C20S	13.5	11.0	41,000	29,520	7.7	39,500	3.4	25,000	2.30	1,400	7/8	3/8	7/8	3/8	7/8	3/8	.076	H4TXV02
	E(C,H,M,U)1P36C	A95UH1E110C20S	13.5	11.0	41,000	29,520	7.7	40,000	3.4	25,000	2.30	1,400	7/8	3/8	7/8	3/8	7/8	3/8	.076	H4TXV02
	E(C,H,M,U)1P43C	A95UH1E110C20S	13.5	11.0	41,000	29,520	7.7	39,500	3.4	25,000	2.30	1,400	7/8	3/8	7/8	3/8	7/8	3/8	.076	H4TXV02
	E(C,H,M,U)1P36C	A95UH2V090C20S	13.5	11.0	41,000	29,520	7.7	40,000	3.4	25,000	2.30	1,400	7/8	3/8	7/8	3/8	7/8	3/8	.076	H4TXV02
	E(C,H,M,U)1P43C	A95UH2V090C20S	13.5	11.0	41,000	29,520	7.7	39,500	3.4	25,000	2.30	1,400	7/8	3/8	7/8	3/8	7/8	3/8	.076	H4TXV02
	E(C,H,M,U)1P36C	A95UH2V110C20S	13.5	11.0	41,000	29,520	7.7	40,000	3.4	25,000	2.30	1,400	7/8	3/8	7/8	3/8	7/8	3/8	.076	H4TXV02
	E(C,H,M,U)1P43C	A95UH2V110C20S	13.5	11.0	41,000	29,520	7.7	39,500	3.4	25,000	2.30	1,400	7/8	3/8	7/8	3/8	7/8	3/8	.076	H4TXV02
4HP13L48P-7	BCS2M48C****P		13.0	11.0	48,000	34,560	7.7	45,000	3.2	28,000	2.40	1,600	7/8	3/8	7/8	3/8	7/8	3/8	.080	H4TXV02
	BCS2M48V****P		14.0	11.0	48,000	34,560	7.7	45,000	3.2	28,000	2.40	1,600	7/8	3/8	7/8	3/8	7/8	3/8	.080	H4TXV02
	BCS3M48C****P		13.0	11.0	48,000	34,560	7.7	45,000	3.2	28,000	2.40	1,600	7/8	3/8	7/8	3/8	7/8	3/8	.080	H4TXV02
4HP13L60P-7	BCS2M60C****P		13.0	11.0	58,000	41,180	7.7	54,000	3.3	34,000	2.30	1,850	7/8	3/8	7/8	3/8	1 1/8	3/8	NA	H4TXV02
	BCS2M60V****P		13.0	11.0	58,000	41,180	7.7	54,000	3.3	34,000	2.30	1,850	7/8	3/8	7/8	3/8	1 1/8	3/8	NA	H4TXV02
	BCS3M60C****P		13.0	11.0	58,000	41,180	7.7	54,000	3.3	34,000	2.30	1,850	7/8	3/8	7/8	3/8	1 1/8	3/8	NA	H4TXV02

Note:

- ¹ Certified in accordance with Unitary Air Conditioner Certification Program, which is based on AHRI Standard 210/240.
- ² Required to achieve AHRI rating. If NA (Not Applicable) is in the piston column, then TXV is required.
- ³ A blower time delay relay is standard on all Allied Air Enterprises furnaces and AH products.

Cooling Performance Extended Ratings

Outdoor Model	Indoor Model	Indoor Temp DB/WB °F	Outdoor Temp - DB°F														
			65°			82°			95°			105°			115°		
			Btuh	S/T	kW	Btuh	S/T	kW	Btuh	S/T	kW	Btuh	S/T	kW	Btuh	S/T	kW
4HP13L18P-7	BCS*M18C****P	85/72	22,900	0.62	1.23	21,200	0.64	1.46	19,900	0.65	1.64	18,700	0.67	1.85	17,400	0.68	2.10
		80/67	20,800	0.69	1.23	19,200	0.70	1.48	18,000	0.71	1.67	16,600	0.74	1.62	15,100	0.77	2.10
		75/63	18,800	0.72	1.23	17,300	0.74	1.47	16,100	0.75	1.65	15,100	0.78	1.87	14,000	0.80	2.08
		75/57	16,600	1.00	1.22	15,400	1.00	1.46	14,400	1.00	1.65	13,500	1.00	1.86	12,600	1.00	2.08
4HP13L24P-7	BCS*M24C****P	85/72	26,300	0.58	1.56	25,900	0.62	1.86	25,600	0.65	2.08	24,000	0.68	2.32	22,500	0.71	2.55
		80/67	25,600	0.66	1.56	24,100	0.70	1.86	23,000	0.73	2.08	21,400	0.74	2.31	19,900	0.75	2.53
		75/63	24,500	0.70	1.56	22,900	0.75	1.84	21,700	0.78	2.06	19,900	0.81	2.28	18,200	0.84	2.50
		75/57	21,500	1.00	1.55	19,900	1.00	1.83	18,700	1.00	2.05	17,400	1.00	2.28	16,200	1.00	2.50
4HP13L30P-7	BCS*M30C****P	85/72	34,600	0.60	2.18	33,100	0.63	2.47	32,000	0.66	2.69	30,100	0.68	2.98	28,400	0.70	3.26
		80/67	33,000	0.66	1.98	30,700	0.71	2.32	29,000	0.74	2.59	27,200	0.76	2.91	25,500	0.78	3.23
		75/63	31,000	0.70	1.97	28,800	0.73	2.30	27,200	0.76	2.55	25,000	0.79	2.88	22,900	0.82	3.22
		75/57	26,200	1.00	1.95	24,300	1.00	2.29	23,000	1.00	2.54	21,900	1.00	2.88	21,000	1.00	3.21
4HP13L36P-7	BCS*M36C****P	85/72	40,900	0.61	2.45	39,700	0.67	2.90	38,700	0.71	3.24	36,900	0.70	3.63	35,000	0.69	4.03
		80/67	39,400	0.67	2.42	36,900	0.70	2.81	35,000	0.72	3.11	33,200	0.75	3.52	31,400	0.77	3.93
		75/63	37,200	0.71	2.40	35,100	0.73	2.85	33,400	0.75	3.20	31,400	0.77	3.51	29,400	0.79	3.83
		75/57	32,900	1.00	2.33	31,000	1.00	2.78	29,600	1.00	3.13	27,800	1.00	3.46	26,000	1.00	3.79
4HP13L42P-7	BCS*M42C****P	85/72	48,400	0.60	2.70	46,900	0.63	3.23	45,700	0.65	3.63	43,000	0.68	4.05	40,200	0.70	4.48
		80/67	46,600	0.66	2.69	43,400	0.69	3.22	41,000	0.72	3.62	38,500	0.76	4.02	35,900	0.79	4.42
		75/63	44,200	0.70	2.69	40,900	0.73	3.20	38,400	0.76	3.59	35,700	0.79	3.97	32,800	0.82	4.35
		75/57	38,200	1.00	2.67	35,600	1.00	3.19	33,600	1.00	3.59	31,200	1.00	3.96	28,700	1.00	4.32
4HP13L48P-7	BCS*M48C****P	85/72	55,600	0.62	3.18	53,900	0.64	3.81	52,700	0.66	4.29	49,500	0.69	4.79	46,200	0.71	5.29
		80/67	52,700	0.69	3.14	50,000	0.71	3.75	48,000	0.72	4.23	44,900	0.74	4.71	41,800	0.75	5.19
		75/63	49,800	0.72	3.10	46,700	0.75	3.70	44,400	0.77	4.15	40,800	0.81	4.65	37,200	0.84	5.14
		75/57	43,700	1.00	3.08	40,500	1.00	3.66	38,200	1.00	4.10	35,800	1.00	4.60	33,400	1.00	5.10
4HP13L60P-7	BCS*M60C****P	85/72	72,700	0.59	4.22	67,400	0.62	4.97	63,500	0.64	5.55	59,800	0.66	6.20	56,200	0.67	6.86
		80/67	66,400	0.68	4.12	61,600	0.70	4.81	58,000	0.71	5.35	54,500	0.74	6.06	51,100	0.76	6.77
		75/63	62,300	0.70	4.09	57,100	0.73	4.79	53,100	0.75	5.32	49,900	0.77	6.02	46,800	0.79	6.72
		75/57	52,700	1.00	4.03	48,600	1.00	4.75	45,400	1.00	5.30	42,900	1.00	6.00	40,500	1.00	6.69

Note:
 Extended data shown is actual for models listed and typical for all AHRI matches.

Heating Performance Extended Ratings

Outdoor Model	Indoor Model	Outdoor Temp. DB/WB°F									
		0/0		17/15		35/33		47/43		62/56	
		Btuh	kW	Btuh	kW	Btuh	kW	Btuh	kW	Btuh	kW
4HP13L18P-7	BCS*M18C****P	6800	1.41	10000	1.46	13000	1.51	17000	1.56	20500	1.61
4HP13L24P-7	BCS*M24C****P	10900	1.70	13000	1.73	17000	1.84	21600	1.92	25500	1.99
4HP13L30P-7	BCS*M30C****P	14500	2.00	17000	2.10	19000	2.26	27000	2.33	32300	2.38
4HP13L36P-7	BCS*M36C****P	13400	2.34	18000	2.40	23000	2.50	33800	2.91	40200	3.01
4HP13L42P-7	BCS*M42C****P	21400	3.10	25000	3.15	29000	3.33	40000	3.35	47500	3.44
4HP13L48P-7	BCS*M48C****P	24900	3.23	28000	3.42	34000	4.11	45000	4.12	53000	4.34
4HP13L60P-7	BCS*M60C****P	29500	4.21	34000	4.33	36000	4.67	55000	4.88	64200	5.10

Note:

Extended data shown is actual for models listed and typical for all AHRI matches.
All ratings are at indoor temperature of 70°F.

Accessories

Description	Where Used	Kit Number
Crankcase Heater	18, 24, 30, 36	93M04
	42, 48, 60	93M05 (factory Installed)
Compressor Low Ambient Kit	18, 24, 30, 36, 42, 48, 60	45F08
Sound Blanket	18, 24, 30, 36	14W00
	42, 48, 60	14W01
Short Cycle Protector	18, 24, 30, 36, 42, 48, 60	47J27 (factory installed, control board feature)
Freezestat	3/8 tubing	93G35
	5/8 tubing	50A93
Time Delay Relay	18, 24, 30, 36, 42, 48, 60	58M81 (factory Installed; control board feature)
Loss of Charge Kit	18, 24, 30, 36, 42, 48, 60	84M23 (factory Installed)



Built for life. Yours.

www.airease.com
1-800-448-5872

All specifications and illustrations
subject to change without notice
and without incurring obligations.