

INSTALLATION AND MAINTENANCE INSTRUCTIONS

4SCU18LT SERIES

Split System Air Conditioner

Save these instructions for future reference

WARNING

The equipment covered in this manual is to be installed by trained and experienced service and installation technicians. Improper installation, modification, service, or use can cause electrical shock, fire, explosion, or other conditions which may cause personal injury, death, or property damage. Use appropriate safety gear including safety glasses and gloves when installing this equipment.

WARNING

Risk of electrical shock. Disconnect all remote power supplies before installing or servicing any portion of the system. Failure to disconnect power supplies can result in property damage, personal injury, or death.

WARNING

Installation and servicing of air conditioning equipment can be hazardous due to internal refrigerant pressure and live electrical components. Only trained and qualified service personnel should install or service this equipment. Installation and service performed by unqualified persons can result in property damage, personal injury, or death.

WARNING

Sharp metal edges can cause injury. When installing the unit, use care to avoid sharp edges.

TABLE OF CONTENTS

INSTALLATION	2
START-UP	13
OPERATION	17
MAINTENANCE	21
CONNECTION DIAGRAM	23
WARRANTY	24

Manufactured By
Allied Air Enterprises, Inc.
A Lennox International Inc. Company
215 Metropolitan Drive
West Columbia, SC 29170



INSTALLATION

General

Read this entire instruction manual, as well as the instructions supplied in separate equipment, before starting the installation. Observe and follow all warnings, cautions, instructional labels, and tags. Failure to comply with these instructions could result in an unsafe condition and/or premature component failure.

These instructions are intended as a general guide only for use by qualified personnel and do not supersede any national or local codes in any way. The installation must comply with all provincial, state, and local codes as well as the National Electrical Code (U.S.) or Canadian Electrical Code (Canada). Compliance should be determined prior to installation.

4SCU18LT condensing units use R410A which is an ozone-friendly HFC refrigerant. The unit must be installed with a matching indoor coil and line set. 4SCU18LT units are designed for use in expansion valve (TXV) systems only. A filter drier approved for use with R410A is installed in the unit.

IMPORTANT: This product has been designed and manufactured to meet ENERGY STAR criteria for energy efficiency when matched with appropriate coil components. However, proper refrigerant charge and proper air flow are critical to achieve rated capacity and efficiency. Installation of this product should follow the manufacturer's refrigerant charging and air flow instructions. **Failure to confirm proper charge and airflow may reduce energy efficiency and shorten equipment life.**

Fastener	Torque
Stem Caps	8 ft. lbs.
Service Port Caps	8 ft. lbs.
Sheet Metal Screws	16 in. lbs.
#8 Machine Screws	16 in. lbs.
#10 Machine Screws	28 in. lbs.
Compressor Bolts	90 in. lbs.

Table 1

When servicing or repairing HVAC components, ensure the fasteners are appropriately tightened. Table 1 shows torque values for fasteners.

Inspection of Shipment

Upon receipt of equipment, carefully inspect it for possible shipping damage. If damage is found, it should be noted on the carrier's freight bill. Take special care to examine the unit inside the carton if the carton is damaged. Any concealed damage discovered should be reported to the last carrier immediately, preferably in writing, and should include a request for inspection by the carrier's agent.

If any damages are discovered and reported to the carrier **DO NOT INSTALL THE UNIT, as claim may be denied.**

Check the unit rating plate to confirm specifications are as ordered.

Location of Unit

Outdoor units operate under a wide range of weather conditions; therefore, multiple factors must be considered when positioning the unit. The unit must be positioned to give adequate clearances for sufficient airflow and servicing. Refer to Figure 1 for installation clearances.

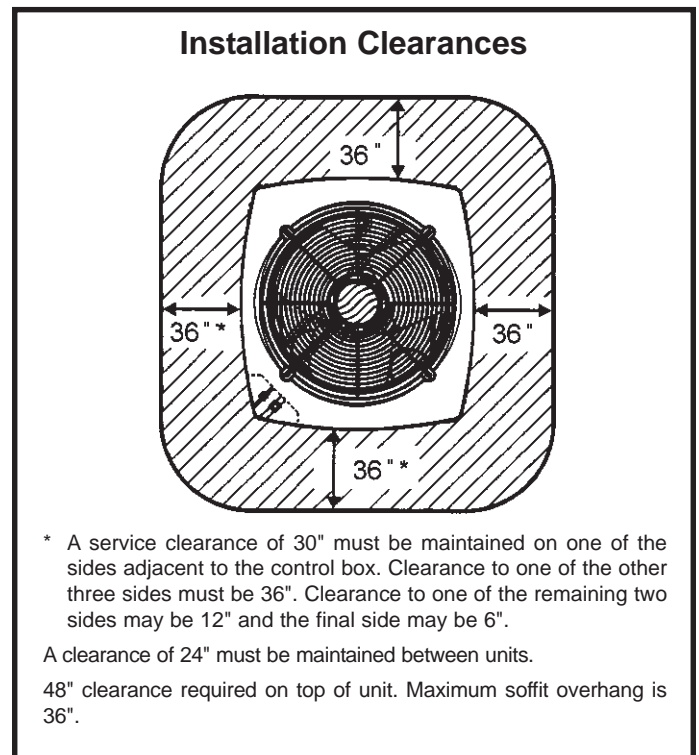

Figure 1

- Install the unit high enough above the ground or roof to allow adequate drainage of defrost water and prevent ice buildup.
- In heavy snow areas, do not locate the unit where drifting snow will occur. The unit base should be elevated above the depth of average snows.

NOTE: Elevation of the unit may be accomplished by construction a frame using suitable materials. If a support frame is constructed, it must not block drain holes in unit base.

- When installed in areas where low ambient temperatures exist, locate unit so winter prevailing winds do not blow directly into outdoor coil.
- Locate unit away from overhanging roof lines which would allow water or ice to drop on, or in front of, coil or into unit.

Slab Mounting

When installing a unit at grade level, install on slab high enough above grade so that water from higher ground will not collect around the unit (See Figure 2). Slab should have a slope tolerance away from the building of 2° or 2" per 5'. This will prevent ice from building up under the unit during a defrost cycle. Refer to following roof mounting section for barrier construction if unit must face prevailing winter winds.

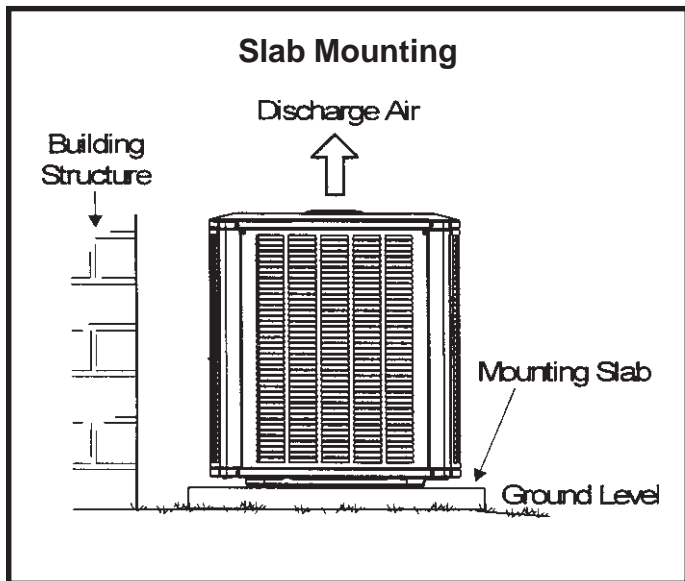

Figure 2

Roof Mounting

Install unit at a minimum of 6" above surface of the roof to avoid ice buildup around the unit. Locate the unit above a load bearing wall or area of the roof that can adequately support the unit. Consult local codes for rooftop applications.

If unit coil cannot be mounted away from prevailing winter winds, a wind barrier should be constructed (See Figure 3). Size the barrier at least the same height and width as the outdoor unit. Mount barrier 24" from the sides of the unit in the direction of the prevailing winds.

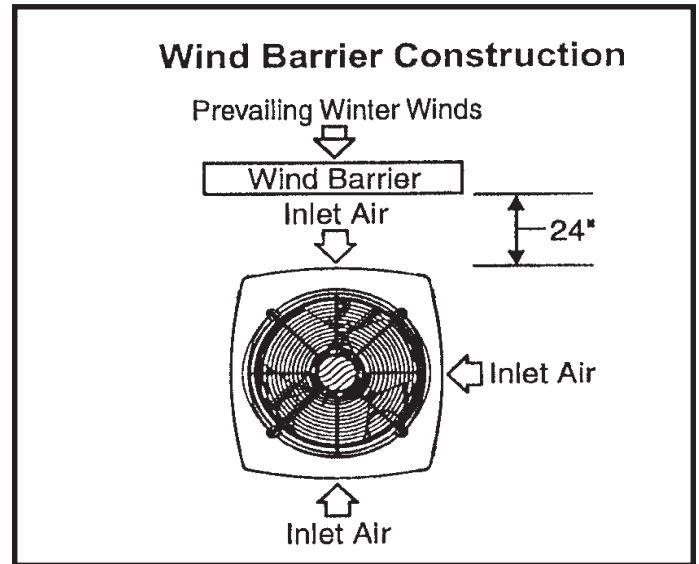

Figure 3

Electrical Wiring

All field wiring must be done in accordance with the National Electrical Code (NEC) recommendations, Canadian Electrical Code (CEC) and CSA Standards, or local codes, where applicable.

Refer to the furnace or blower coil installation instructions for additional wiring application diagrams and refer to unit rating plate for minimum circuit ampacity and maximum overcurrent protection size.

⚠ WARNING

Unit must be grounded in accordance with national and local codes. Failure to ground unit properly can result in personal injury or death.

⚠ WARNING

Line voltage is present at all components when unit is not in operation on units with single pole contactors. Disconnect all remote electric power supplies before opening access panel. Unit may have multiple power supplies. Failure to disconnect all power supplies could result in personal injury or death.

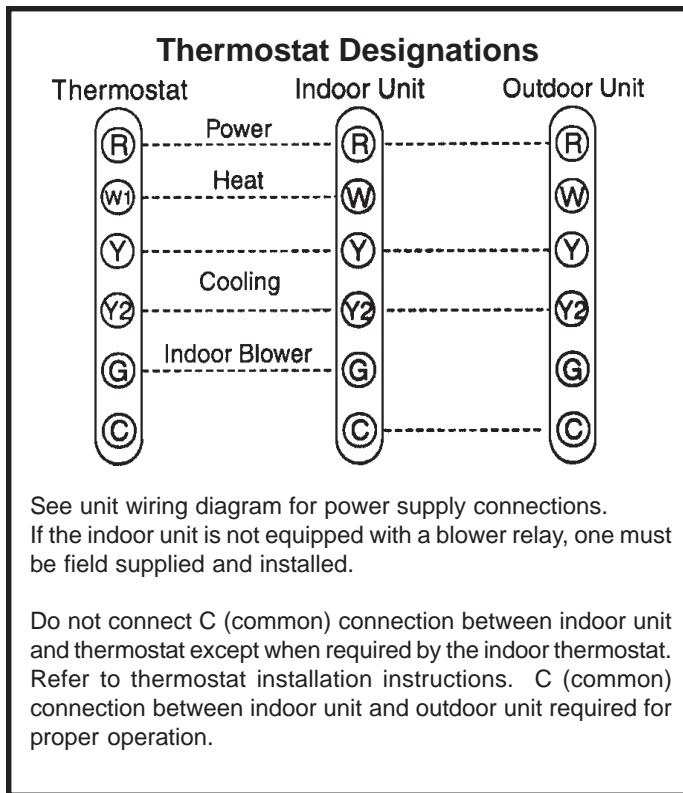

Figure 4

1. Install line voltage power supply to unit from a properly sized disconnect switch. Any excess high voltage field wiring should be trimmed or secured away from the low voltage field wiring.
2. Ground unit at unit disconnect switch or to an earth ground. To facilitate conduit, a hole is in the bottom of the control box. Connect conduit to the control box using a proper conduit fitting. Units are approved for use only with copper conductors. 24V Class II circuit connections are made in the low voltage junction box. Refer to Figure 4 for high voltage field wiring diagram. A complete unit wiring diagram is located inside the unit control box cover.
3. Install room thermostat on an inside wall that is not subject to drafts, direct sunshine, or other heat sources.
4. Install low voltage wiring from outdoor to indoor unit and from thermostat to indoor unit (See Figure 5).
5. Do not bundle any excess 24V control wire inside control box. Run control wire through installed wire tie and tighten wire tie to provide low voltage strain relief and to maintain separation of field-installed low and high voltage circuits.

Refrigerant Piping

If the 4SCU18LT unit is being installed with a new indoor coil and line set, the refrigerant connections should be made as outlined in this section. If an existing line set and/or indoor coil will be used to complete the system, refer to this section as well as the section that follows entitled - **Flushing Existing Line Set and Indoor Coil.**

If this unit is being matched with an approved line set or indoor coil which was previously charged with R-22 refrigerant, the line set and coil must be flushed prior to installation. If the unit is being used with an existing indoor coil which was equipped with a liquid line which served as a metering device (RFCI), the liquid line must be replaced prior to the installation of the 4SCU18LT unit.

Field refrigerant piping consists of liquid and suction lines from the outdoor unit (sweat connections) to the indoor coil (flare or sweat connections).

Select line set diameters from Table 2 to ensure that oil returns to the compressor. Size vertical suction riser to maintain minimum velocity at minimum capacity. Recommended line length is 50' or less. If more than 50' line set is required, contact Technical Services. Table 2 shows the diameters for line sets up to 100' although vertical lift applications and trapping requirements need to be reviewed with Technical Services for line sets over 50'.

Installing Refrigerant Line

During the installation of an air conditioning system, it is important to properly isolate the refrigerant line to prevent unnecessary vibration. Line set contact with the structure (wall, ceiling, or floor) may cause objectionable noise when vibration is translated into sound. As a result, more energy or vibration can be expected. Close attention to line set isolation must be observed.

Following are some points to consider when placing and installing a high-efficiency outdoor unit:

Placement

Be aware that some localities are adopting sound ordinances based on how noisy the unit is at the neighbor's home, not at the original installation. Install the unit as far as possible from the property line. When possible, do not install the unit directly outside a bedroom window. Glass has a very high level of sound transmission. Figure 5 on page 5 shows how to place the outdoor unit and line set to reduce line set vibration.

Line Set Isolation

Illustrations on the pages 6 and 7 demonstrate procedures which ensure proper refrigerant line set isolation. Figure 6 shows how to install line sets on horizontal runs. Figure 7 shows how to make a transition from horizontal to vertical. Figure 9 shows how to install line sets on vertical runs.

Refrigerant Line Set Diameters (in.)					
Liquid Line					
BTUH	Line Set Length and Size				
	12 ft.	25 ft.	50 ft.	75 ft.	100 ft.
24,000	3/8	3/8	3/8	3/8	3/8
36,000	3/8	3/8	3/8	3/8	1/2
48,000	3/8	3/8	3/8	1/2	1/2
60,000	3/8	3/8	3/8	1/2	1/2

Suction Line					
BTUH	Line Set Length and Size				
	12 ft.	25 ft.	50 ft.	75 ft.	100 ft.
24,000	3/4	7/8	3/4	7/8	7/8
36,000	7/8	7/8	7/8	7/8	1-1/8
48,000	7/8	7/8	7/8	1-1/8	1-1/8
60,000	1/8	1/8	1-1/8	1-1/8	1-1/8

For installations exceeding 50', contact Technical Services.

Table 2

Brazing Connection Procedure

1. Cut ends of refrigerant lines square (free from nicks or dents). Debur the ends. The pipe must remain round; do not pinch end of line.
2. Before making line set connections, use dry nitrogen to purge the refrigerant piping. This will help to prevent oxidation and the introduction of moisture into the system.
3. Use silver alloy brazing rods (5% or 6% silver alloy for copper-to-copper brazing or 45% silver alloy for copper-to-brass or copper-to-steel brazing) which are rated for use with R410A refrigerant.
4. Remove the Schrader core assemblies before brazing to protect them from damage due to extreme heat. Replace the cores when brazing is complete.
5. Remove light maroon washers from service valves and shield light maroon stickers to protect them during brazing. Wrap a wet cloth around the valve body and copper tube stub to protect it from heat damage.

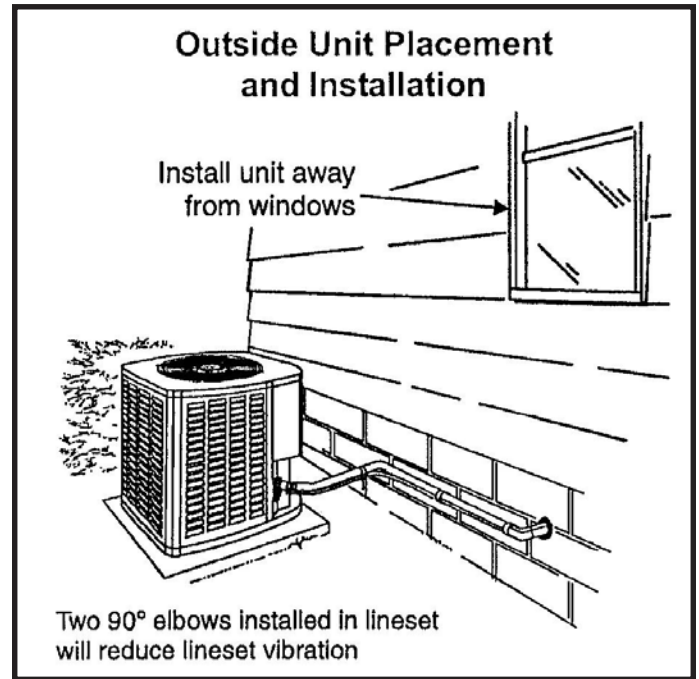

Figure 5

6. Braze the line set to the service valve. Quench the joints with water or a wet cloth to prevent heat damage to the valve core and opening port. **The tube end must stay bottomed in the fitting during final assembly to ensure proper seating, sealing, and rigidity.**

7. Install the thermal expansion valve which is sold separately and which is approved for use with R410A refrigerant in the liquid line at the indoor coil (see **Refrigerant Metering Device** on page 9).

CAUTION

When flushing existing line set and/or indoor coil, be sure to empty all existing traps. Residual mineral oil can act as an insulator, preventing proper heat transfer. It can also clog the thermal expansion valve, reducing system performance and capacity. Failure to properly flush system as explained in these instructions will void warranty.

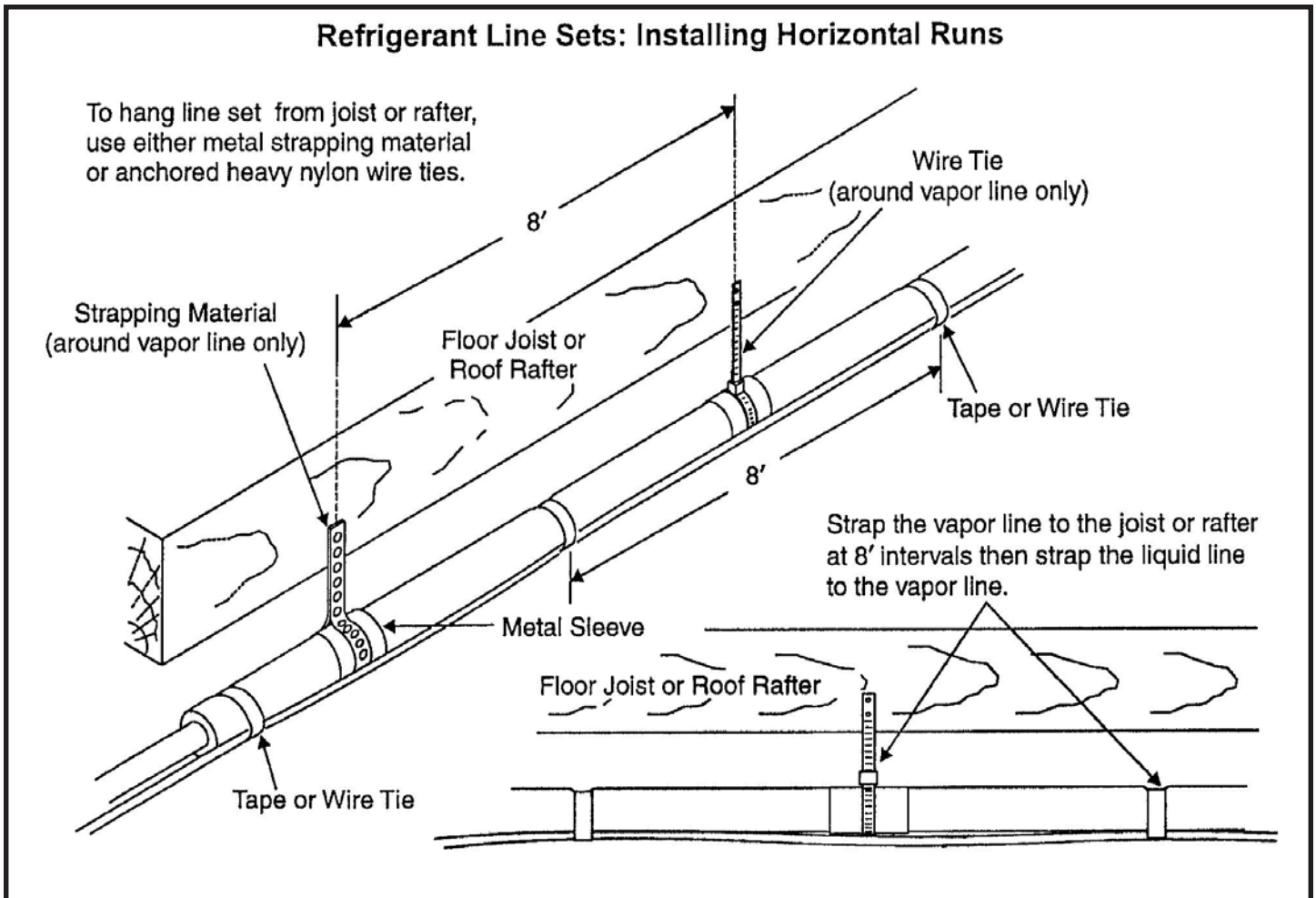

Figure 6

Refrigerant Line Sets: Transition from Vertical to Horizontal

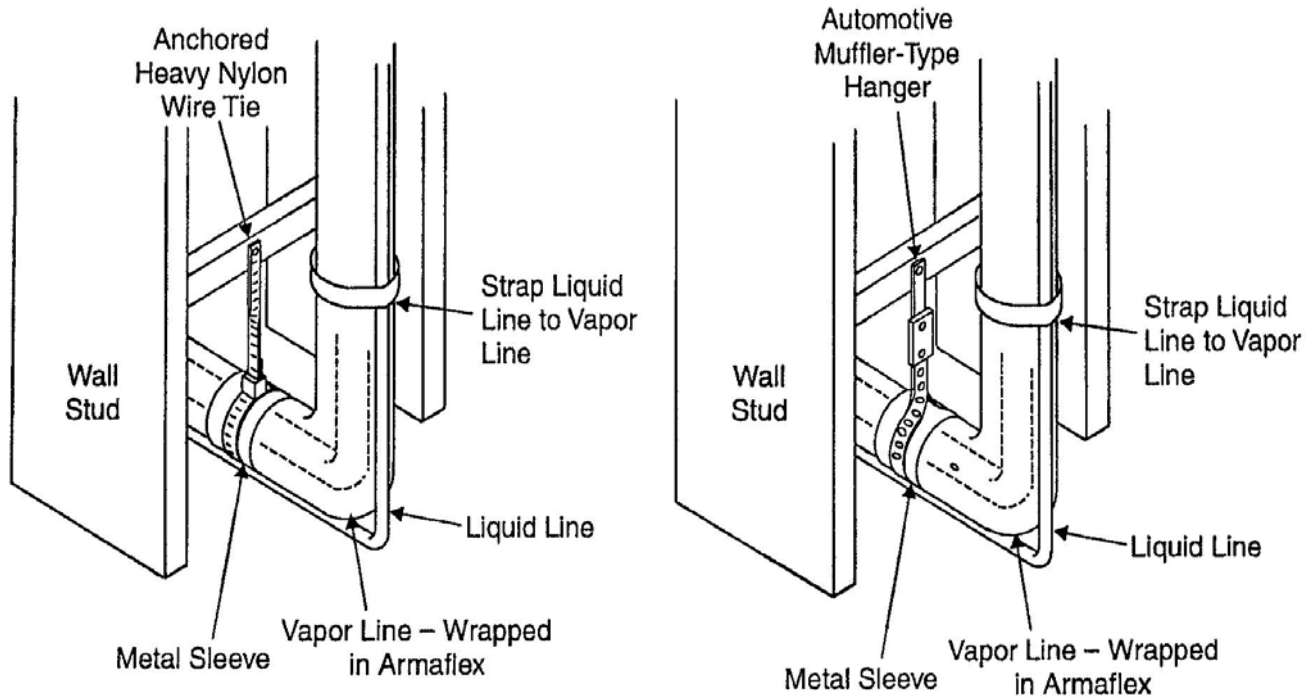

Figure 7

Refrigerant Line Sets: Installing Vertical Runs (new construction shown)

NOTE: Similar installation practices should be used if line set is to be installed on exterior of outside wall.

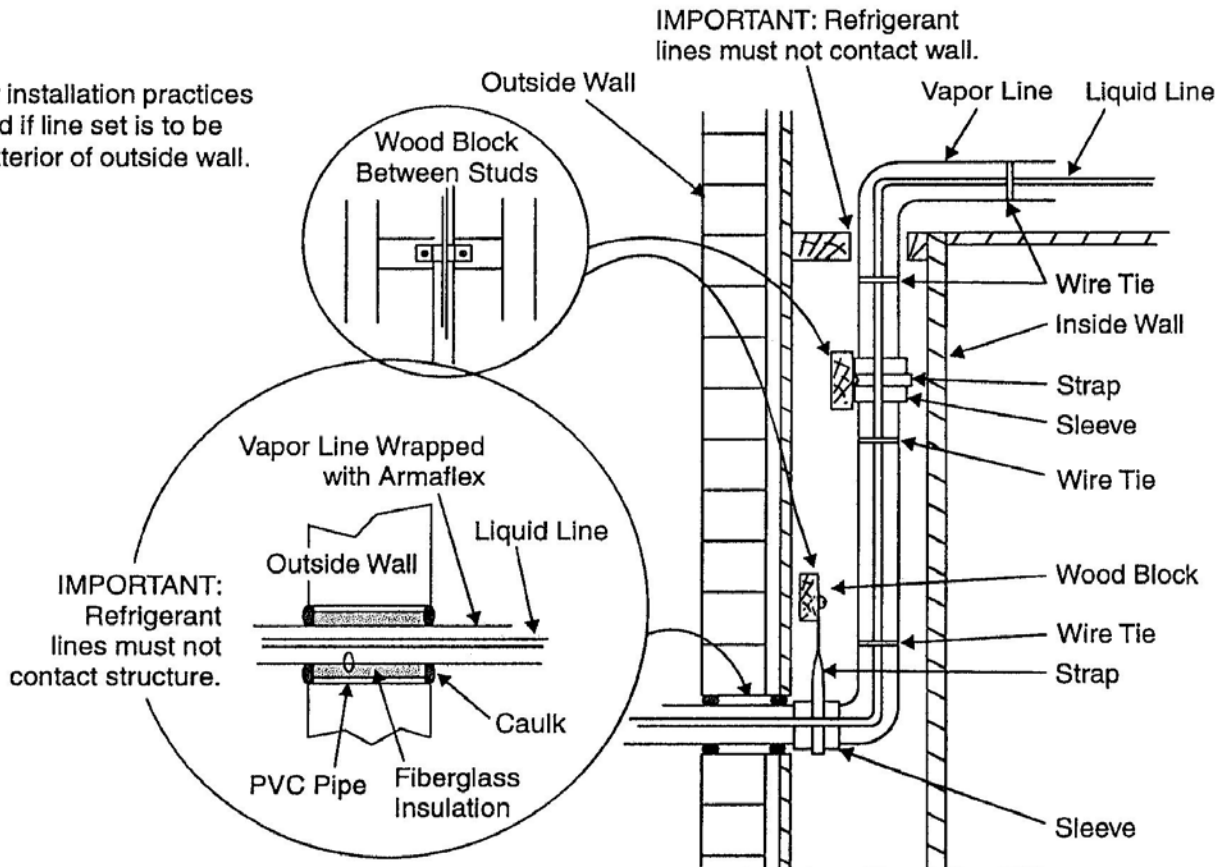

Figure 8

Flushing Existing Line Set and Indoor Coil

This procedure should not be performed on systems which contain contaminants, such as compressor burn out.

Required Equipment

The following equipment is needed to flush the existing line set and indoor coil (See Figure 9). Two clean R-22 recovery bottles, an oil-less recovery machine with a "pump down" feature, and two sets of gauges (one for use with R-22 and one for use with R410A).

Flushing Procedure

IMPORTANT: The line set and/or indoor coil must be flushed with at least the same amount of refrigerant that previously charged the system. Check the charge in the flushing cylinder before flushing the unit.

1. Remove existing R-22 refrigerant using the appropriate procedure.

If the existing outdoor unit is not equipped with shutoff valves, or if the unit is not operational AND the existing R-22 refrigerant will be used to flush the system:

Disconnect all power to the existing outdoor unit. Connect the existing unit, a clean recovery cylinder, and the recovery machine according to the instructions provided with the recovery machine. Remove all R-22 refrigerant from the existing system. Refer to the gauges after shutdown to confirm that the entire system is completely void of refrigerant. Disconnect the liquid and suction lines from the existing outdoor unit.

If the existing outdoor unit is equipped with manual shutoff valves AND new R-22 refrigerant will be used to flush the system:

Start the existing R-22 refrigerant system in cooling mode and close the liquid line valve. Pump all the existing R-22 refrigerant back into the outdoor unit.

(It may be necessary to bypass the low pressure switches to ensure complete refrigerant evacuation.)

When the low side system pressures reach 0 psig, close the suction line valve. Disconnect all power to the existing outdoor unit. Refer to the gauges after shutdown to confirm that the valves are not allowing refrigerant to flow back into the low side of the system. Disconnect the liquid and suction lines from the existing outdoor unit.

2. Remove the existing outdoor unit. Set the new R410A unit and follow the brazing connection procedure outlined previously on this page to make line set connections. **Do not install the R410A thermal expansion valve at this time.**

3. Make low voltage and line voltage connections to the new outdoor unit. **Do not turn on power to the unit or open the outdoor unit service valves at this time.**

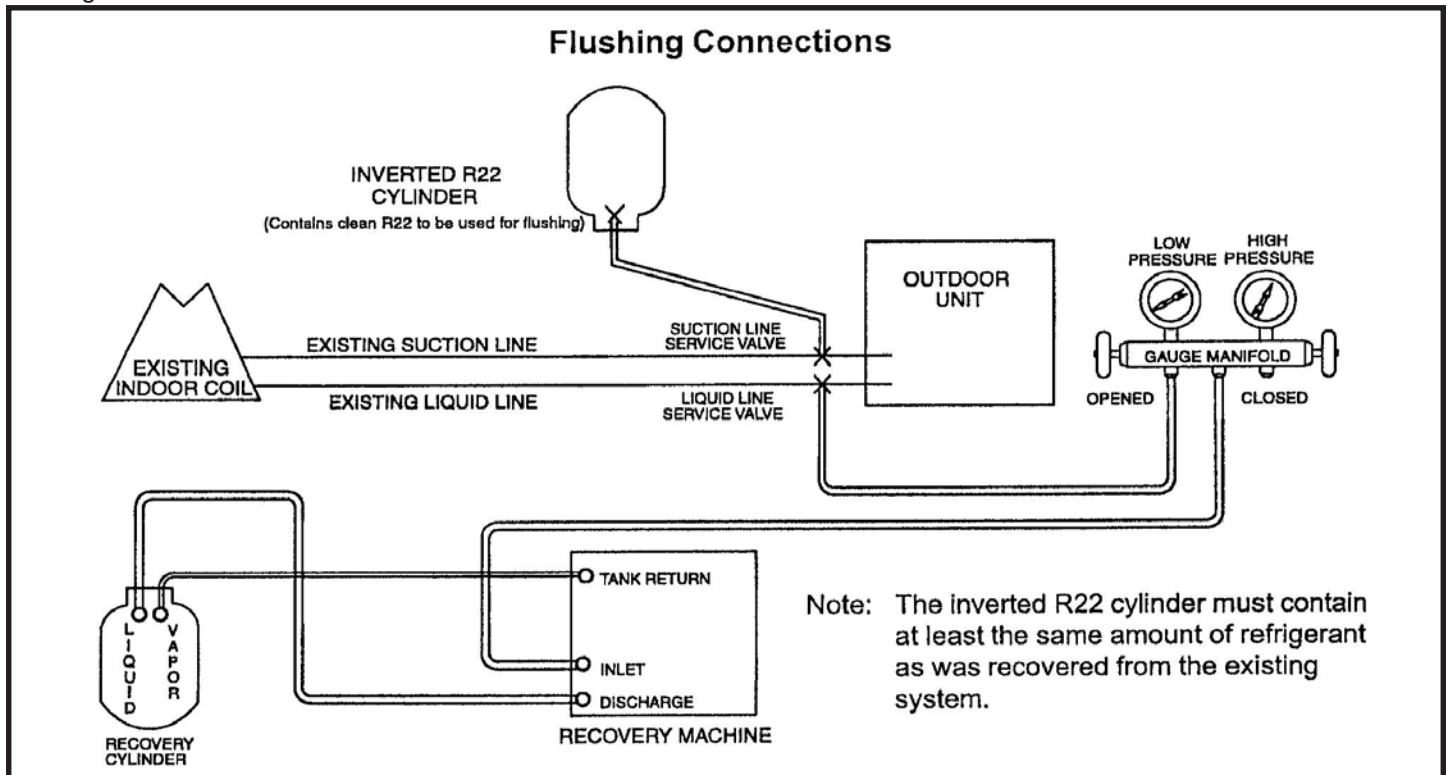

Figure 9

4. Remove the existing R-22 refrigerant flow control orifice or thermal expansion valve before continuing with flushing procedures. R-22 flow control devices are not approved for use with R410A refrigerant and may prevent proper flushing. Use a field-provided fitting to reconnect the lines.

5. Remove the pressure tap valve cores from the 4SCU18LT units service valves. Connect an R-22 cylinder with clean refrigerant to the suction service valve. Connect the R-22 gauge set to the liquid line valve and connect a recovery machine with an empty recovery tank to the gauge set.

6. Set the recovery machine for liquid recovery and start the recovery machine. Open the gauge set valves to allow the recovery machine to pull a vacuum on the existing system line set and indoor coil.

7. Invert the cylinder of clean R-22 and open its valve to allow liquid refrigerant to flow in to the system through the suction line valve. Allow the refrigerant to pass from the cylinder and through the line set and the indoor coil before it enters the recovery machine.

8. After all of the liquid refrigerant has been recovered, switch the recovery machine to vapor recovery so that all of the R-22 vapor is recovered. Allow the recovery machine to pull a vacuum on the system.

NOTE: A single system flush should remove all of the mineral oil from the existing refrigerant lines and indoor coil. A second flushing may be done (using clean refrigerant) if insufficient amounts of mineral oil were removed during the first flush. **After each system flush, allow the recovery machine to pull a vacuum on the system at the end of the procedure.**

9. Close the valve on the inverted R-22 cylinder and the gauge set valves. Pump the remaining refrigerant out of the recovery machine and turn the machine off.

10. Use nitrogen to break the vacuum on the refrigerant lines and indoor coil before removing the recovery machine, gauges, and R-22 refrigerant drum. Re-install pressure tap valve cores into the 4SCU18LT unit's service valves.

11. Install the fixed orifice (or thermal expansion valve approved for use with R410A refrigerant) in the liquid line at the indoor coil.

Refrigerant Metering Device

4SCU18LT units are designed for use with TXV systems. Refer to the appropriate following section for information on installing the chosen refrigerant metering device.

An R410A system will not operate properly with an R-22 metering device.

Install the refrigerant metering device as shown in Figure 10. Do not twist cap tubes when loosening the seal nut from the orifice housing. Use wrench to back up the distributor.

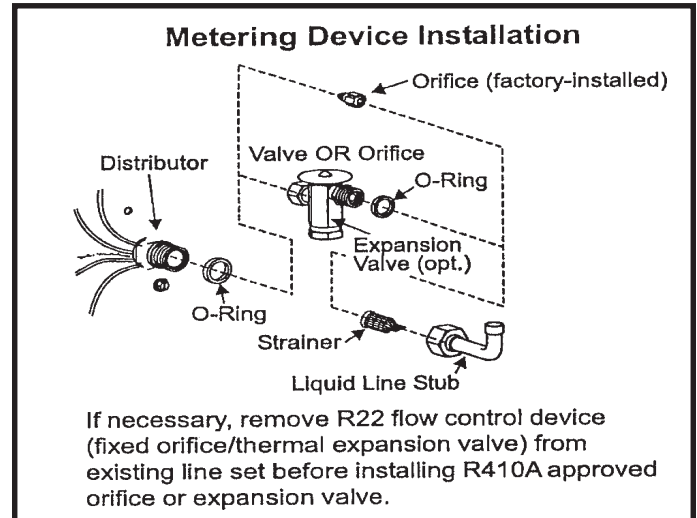

Figure 10

Expansion Valve Systems

Expansion valves equipped with Chatleff-type fittings are available from the manufacturer. See Table 4 for proper TXV for each unit.

TXV Data	
MODEL	PART NUMBER
4SCU18LT- 24, -36	A4TXV01
4SCU18LT - 48, -60	A4TXV03

Table 4

To install an expansion valve (See Figure 10 above):

1. Separate the distributor assembly and remove the piston orifice and used teflon seal. Insert nozzle end of the expansion valve along with a new teflon seal into the distributor and tighten to 20 - 30 ft. lbs. Use backup wrench on all wrench flats. **Overtightening will crush the teflon seal and may cause a leak.**

2. Attach liquid line portion of distributor assembly along with new teflon seal to the inlet of the expansion valve. Tighten to 20 - 30 ft. lbs. Use backup wrench on all wrench flats. **Overtightening will crush the teflon seal and may cause a leak.**

3. Connect the external equalizer line to the equalizer port on the suction line and tighten to 8 ft.lbs.
4. Strap the superheat sensing bulb to the suction header.

If installing an expansion valve on an indoor coil that previously used a fixed orifice, be sure to remove the existing fixed orifice. Failure to remove a fixed orifice when installing an expansion valve to the indoor coil will result in improper operation and damage to the system.

Manifold Gauge Set

Manifold gauge sets used with systems charged with R410A refrigerant must be capable of handling the higher system operating pressures. The gauges should be rated for use with pressures 1 - 800 on the high side and a low side of 30" vacuum to 250 psi with dampened speed to 500 psi. Gauge hoses must be rated for use at up to 800 psi of pressure with a 4000 psi burst rating.

Liquid and Suction Line Service Valves

The liquid line and suction line service valves (See Figure 11) and service ports are used for leak testing, evacuation, charging, and checking charge.

Each valve is equipped with a service port which has a factory-installed Schrader valve. A service port cap protects the Schrader valve from contamination and serves as the primary leak seal.

To Access the Schrader Port:

1. Remove the service port cap with an adjustable wrench.
2. Connect gauge to the service port.
3. When testing is completed, replace service port cap. Tighten finger tight, then an additional 1/6 turn.

To Open Liquid or Suction Line Service Valve:

Remove stem cap with an adjustable wrench.

Use service wrench with a hex-head extension to back the stem out counterclockwise as far as it will go. Use a 3/16" hex head extension for liquid line service valves and a 5/16" extension for suction line service valves.

Replace the stem cap. Tighten finger tight, then tighten an additional 1/6 turn.

To Close Liquid or Suction Line Service Valve:

1. Remove the stem cap with an adjustable wrench.
2. Use a service wrench with a hex-head extension to turn the stem clockwise to seat the valve. Tighten firmly.
3. Replace the stem cap. Tighten finger tight, then tighten an additional 1/6 turn.

Suction Line (Ball Type) Service Valve

Suction line (ball type) service valves function the same way as the other valves; the difference is in the construction (See Figure 12).

The ball valve is equipped with a service port with a factory-installed Schrader valve. A service port cap protects the Schrader valve from contamination and serves as the primary seal.

Leak Testing

After the line set has been connected to the indoor and outdoor units, the line set connections and indoor unit must be checked for leaks.

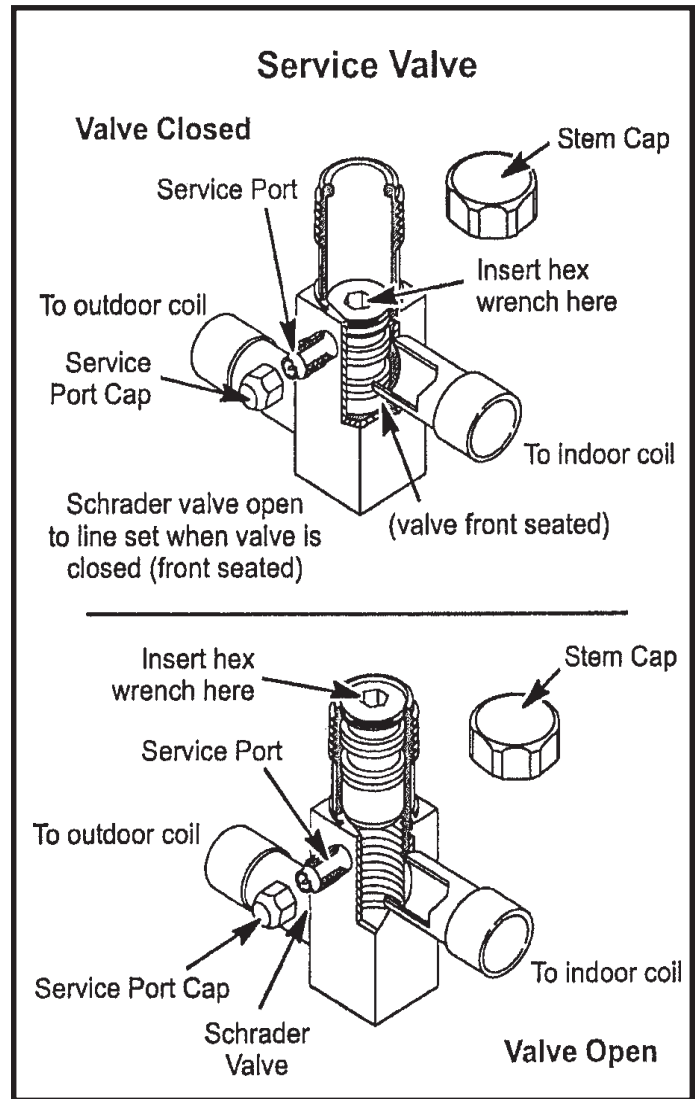

Figure 11

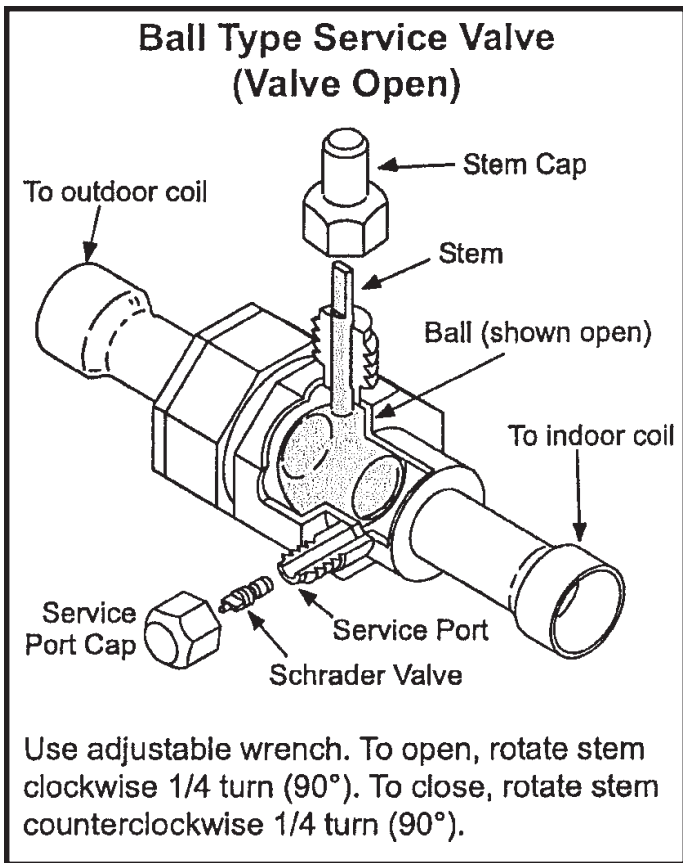

Figure 12

⚠ WARNING

Refrigerant can be harmful if inhaled. Refrigerant must always be used and recovered responsibly. Incorrect or irresponsible use of refrigerant can result in personal injury or death.

⚠ WARNING

Never use oxygen to pressurize refrigeration or air conditioning systems. Oxygen will explode on contact with oil and could cause personal injury or death.

Using an Electronic Leak Detector

1. Connect the high pressure hose of the manifold gauge set to the suction valve service port. (Normally the high pressure hose is connected to the liquid line port; however, connecting it to the suction ports helps to protect the manifold gauge set from damage caused by high pressure.)
2. With both manifold valves closed, connect the cylinder of R410A refrigerant. Open the valve on the R410A cylinder (vapor only).

3. Open the high pressure side of the manifold to allow R410A into the line set and indoor unit. Weigh in a trace amount of R410A. (A trace amount is a maximum of 2 oz. of refrigerant or 3 lbs. pressure.) Close the valve on the R410A cylinder and the valve on the high pressure side of the manifold gauge set. Disconnect the R410A cylinder.

4. Connect a cylinder of nitrogen with a pressure regulating valve to the center port of the manifold gauge set. **When using high pressure gas such as nitrogen for this purpose, be sure to use a regulator that can control the pressure down to 1 or 2 psig.**

5. Adjust nitrogen pressure to 150 psig. Open the valve on the high side of the manifold gauge set to pressurize the line set and the indoor coil.

6. After a short period of time, open a refrigerant port to make sure that an adequate amount of refrigerant has been added for detection (refrigerant requirements will vary with lengths). Check all joints for leaks. Purge nitrogen and R410A mixture. Correct any leaks and rechecks.

Evacuation

Evacuating the system of noncondensables is critical for proper operation of the unit. Noncondensables are defined as any gas that will not condense under temperatures and pressures present during operation of an air conditioning system. Noncondensables and water vapor combine with refrigerant to produce substances that corrode copper piping and compressor parts.

⚠ WARNING

Do Not use a compressor to evacuate a system. Avoid deep vacuum operation. Extremely low vacuums can cause internal arcing and compressor failure. Danger of equipment damage. Damage caused by deep vacuum operation will void warranty.

Use a thermocouple or thermistor electronic vacuum gauge that is calibrated in microns. Use an instrument that reads down to 50 microns.

1. Connect the manifold gauge set to the service valve ports as follows:

- Low pressure gauge to suction line service valve
- High pressure gauge to liquid line service valve.

2. Connect micron gauge.

3. Connect the vacuum pump (with vacuum gauge) to the center port of the manifold gauge set.

4. Open both manifold valves and start vacuum pump.
5. Evacuate the line set and indoor unit to a minimum of 500 microns or lower. During the early stages of evacuation, it is desirable to close the manifold gauge valve at least once to determine if there is a rapid rise in pressure. A rapid rise in pressure indicates a relatively large leak. If this occurs, the leak testing procedure must be repeated.
6. When 500 microns or lower is maintained, close the manifold gauge valves, turn off the vacuum pump, and disconnect the manifold gauge center port hose from the vacuum pump. Attach the manifold gauge center port hose to a nitrogen cylinder with pressure regulator set to 150 psig and purge the hose. Open the manifold gauge valves to break the vacuum in the line set and indoor unit. Close the manifold gauge valves.
7. Shut off the nitrogen cylinder and remove the manifold gauge hose from the cylinder. Open the manifold gauge valves to release the nitrogen from the line set and indoor unit.
8. Reconnect the manifold gauge to the vacuum pump, turn the pump on, and continue to evacuate the line set and indoor unit until 500 microns is maintained within a 20 minute period after shutting off the vacuum pump and closing the manifold gauge valves.
9. When the requirements above have been met, disconnect the manifold hose from the vacuum pump. Open the service valves to break the vacuum in the line set and indoor unit.

START-UP

CAUTION

If unit is equipped with a crankcase heater, it should be energized 24 hours before unit start-up to prevent compressor damage as a result of slugging.

1. Rotate fan to check for frozen bearings or binding.
2. Inspect all factory and field-installed wiring for loose connections.
3. After evacuation is complete, open liquid line and suction line service valves to release refrigerant charge (contained in outdoor unit) into system.
4. Replace the stem caps and secure finger tight, then tighten an additional 1/6 of a turn.
5. Check voltage supply at the disconnect switch. The voltage must be within the range listed on the unit nameplate. If not, do not start equipment until the power company has been consulted and the voltage condition corrected.
6. Set thermostat for cooling demand, turn on power to indoor blower, and close the outdoor unit disconnect switch to start the unit.
7. Recheck unit voltage with unit running. Power must be within range shown on unit nameplate.

Refrigerant Charging

This system is charged with R410A refrigerant which operates at much higher pressures than R-22. The liquid line drier provided with the unit is approved for use with R410A. Do not replace it with one designed for use with R-22. **This unit is NOT approved for use with coils which use capillary tubes as a refrigerant metering device.**

R410A refrigerant cylinders are rose colored. Refrigerant should be added through the suction valve in the liquid state.

Certain R410A cylinders are identified as being equipped with a dip tube. These allow liquid refrigerant to be drawn from the bottom of the cylinder without inverting the cylinder. Do not turn this type of cylinder upside down to draw refrigerant.

Units are factory charged with the amount of R410A refrigerant indicated on the unit rating plate. This charge is based on a matching indoor coil and outdoor coil with 15' line set. For varying lengths of line set, refer to Table 5 for refrigerant charge adjustment. A blank space is provided on the unit rating plate to list the actual field charge.

Refrigerant Charge Adjustment

Liquid Line Set Diameter	Oz. Per 5 ft. adjust from 15 ft. line set*
3/8 in.	3 oz. Per 5 ft.

* If line length is greater than 15 ft., add this amount.
If line length is less than 15 ft., remove this amount.

Table 5

IMPORTANT

Mineral oils are not compatible with R410A. If oil must be added, it must be a polyolester oil.

If the system is void of refrigerant, clean the system using the procedure described below.

1. Use dry nitrogen to pressurized the system and check for leaks. Repair leaks, if possible.
2. Evacuate the system to remove as much of the moisture as possible.
3. Use dry nitrogen to break the vacuum.
4. Evacuate the system again.
5. Weigh the appropriate amount of R410A refrigerant (listed on unit nameplate) into the system.
6. Monitor the system to determine the amount of moisture remaining in the oil. Use a test kit to verify that the moisture content is within the kit's dry color range. It may be necessary to replace the filter drier several times to achieve the required dryness level. **If system dryness is not verified, the compressor will fail in the future.**

The outdoor unit should be charged during warm weather. However, applications arise in which charging must occur in the colder months. The method of charging is determined by the unit's **refrigerant metering device** and the **outdoor ambient temperature**.

Measure the liquid line temperature and the outdoor ambient temperature as outlined below:

1. Connect the manifold gauge set to the service valve ports as follows (See Figure 13):

- Low pressure gauge to suction line service valve
- High pressure gauge to liquid line service valve

2. Close manifold gauge set valves. Connect the center manifold hose to an upright cylinder of R410A.

3. If room temperature is below 70°F, set the room thermostat to call for heat. This will create the necessary load for properly charging the system in the cooling cycle.

4. Use a digital thermometer to record the outdoor ambient temperature.

5. When the heating demand has been satisfied, switch the thermostat to cooling mode with a set point of 68°F. When pressures have stabilized, use a digital thermometer to record the liquid and suction line temperatures.

6. The outdoor temperature will determine which charging method to use. Proceed with the appropriate charging method.

Charge Using Subcooling Method - Outdoor Temperatures Below 65°F

When the outdoor ambient temperature is below 65°F, the subcooling method can be used to charge the unit. It may be necessary to restrict the air flow through the outdoor coil to achieve pressures in the 200-250 psig range. These higher pressures are necessary for checking the charge. Block equal sections of air intake panels and move obstructions sideways until the liquid pressure is in the 200-250 psig range (see Figure 11).

1. With the manifold gauge hose on the liquid service port and the unit operating stably, use a digital thermometer to record the liquid line temperature.
2. At the same time, record the liquid line pressure reading.
3. Use the temperature/pressure chart (Table 5 on page 14) to determine the saturation temperature for the liquid line pressure reading.
4. Subtract the liquid line temperature from the saturation temperature (according to the chart) to determine subcooling

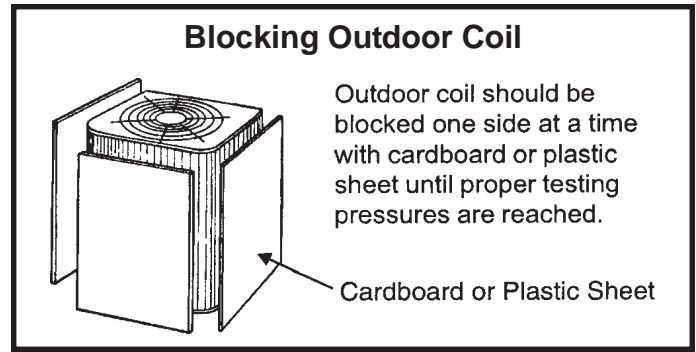

Figure 11

- ° Saturation Temperature °F
- — ° Liquid Line Temperature °F
- = — ° Subcooling Value °F

5. Compare the subcooling value with those shown in Table 6 on page 14. If subcooling is greater than shown, recover some refrigerant. If subcooling is less than shown, add some refrigerant.

Charge Using Approach Method - Outdoor Temperatures 65°F or Above

The following procedure is intended as a general guide and is for use on expansion valve systems only. For best results, indoor temperature should be 70°F to 80°F. Monitor system pressures while charging.

1. Record outdoor ambient temperature using a digital thermometer.
2. Attach high pressure gauge set and operate unit for several minutes to allow system pressures to stabilize.
3. Compare stabilized pressures with those provided in Table 8 on page 15. Minor variations in these pressures may be expected due to differences in installations. **Significant differences could mean that the system is not properly charged or that a problem exists with some component in the system.** Pressures higher than those listed indicate that the system is undercharged. Verify adjusted charge using the approach method.
4. Use the same digital thermometer to check liquid line temperature.
5. Subtract the outdoor ambient temperature from the liquid line temperature to determine the approach temperature.

R410A Temperature/Pressure Chart

Temp. °F	Pressure Psig	Temp. °F	Pressure Psig	Temp. °F	Pressure Psig
32	100.8	74	214.0	116	396.0
33	102.9	75	217.4	117	401.3
34	105.0	76	220.9	118	406.7
35	107.1	77	224.4	119	412.2
36	109.2	78	228.0	120	417.7
37	111.4	79	231.6	121	423.2
38	113.6	80	235.3	122	428.8
39	115.8	81	239.0	123	434.5
40	118.0	82	242.7	124	440.2
41	120.3	83	246.5	125	445.9
42	122.6	84	250.3	126	451.8
43	125.0	85	254.1	127	457.6
44	127.3	86	258.0	128	463.5
45	129.7	87	262.0	129	469.5
46	132.2	88	266.0	130	475.6
47	134.6	89	270.0	131	481.6
48	137.1	90	274.1	132	487.8
49	139.6	91	278.2	133	494.0
50	142.2	92	282.3	134	500.2
51	144.8	93	286.5	135	506.5
52	147.4	94	290.3	136	512.9
53	150.1	95	295.1	137	519.3
54	152.8	96	299.4	138	525.8
55	155.5	97	303.8	139	532.4
56	158.2	98	308.2	140	539.0
57	161.0	99	312.7	141	545.6
58	163.9	100	317.2	142	552.3
59	166.7	101	321.8	143	559.1
60	169.6	102	326.4	144	565.9
61	172.6	103	331.0	145	572.8
62	175.5	104	335.7	146	579.8
63	178.5	105	340.5	147	586.8
64	181.6	106	345.3	148	593.8
65	184.3	107	350.1	149	601.0
66	187.7	108	355.0	150	608.1
67	190.9	109	360.0	151	615.4
68	194.1	110	365.0	152	622.7
69	197.3	111	370.0	153	630.1
70	200.6	112	375.1	154	637.5
71	203.9	113	380.2	155	645.0
72	207.2	114	385.4		
73	210.6	115	390.7		

Table 6

Subcooling Values

Model	-24	-36	-48	-60
Temp. °F	6	5	4	5

Table 7

- _____ ° Saturation Temperature °F
- _____ ° Liquid Line Temperature °F
- = _____ ° Subcooling Value °F

6. Compare the approach value with those shown in Table 7.
 7. If the values do not agree with those provided in Table 7, add refrigerant to lower the approach temperature or recover refrigerant from the system to increase the approach temperature.

Approach Values for TXV Systems

Model	-24	-36	-48	-60
Temp. °F	1	2	1	5

Approach value is the liquid line temperature minus the outdoor ambient temperature ($\pm 1^\circ\text{F}$).

Note: For best results, use the same digital thermometer to check both outdoor ambient and liquid temperatures.

Table 8

Check Charge Using Normal Operating Pressures

Use Table 8 to perform maintenance checks. Table 8 is not a procedure for charging the system. Minor variations in these pressures may be due to differences in installations. Significant deviations could mean that the system is not properly charged or that a problem exists with some component in the system.

- _____ ° Liquid Line Temperature °F
- _____ ° Outdoor Ambient Temperature °F
- = _____ ° Approach Temperature °F

Normal Operating Pressures								
Low Capacity								
Outdoor Coil Entering Air Temp. °F	24		36		48		60	
	L	S	L	S	L	S	L	S
65	205	140	203	139	196	142	236	132
75	247	142	242	141	240	144	278	136
85	288	145	287	144	294	149	321	140
95	330	147	344	147	348	150	363	144
105	372	148	391	149	402	151	405	148
115	413	151	438	153	456	154	447	152
High Capacity								
Outdoor Coil Entering Air Temp. °F	24		36		48		60	
	L	S	L	S	L	S	L	S
65	212	137	210	141	237	137	248	123
75	254	139	247	143	286	139	293	128
85	295	142	298	145	330	140	337	132
95	337	144	349	147	374	142	382	137
105	379	146	400	149	418	144	427	142
115	424	149	451	151	462	145	471	146

Table 8

OPERATION

Outdoor unit and indoor blower cycle on demand from the room thermostat. When the thermostat blower switch is moved to the ON position, the indoor blower operates continuously.

System Diagnostic Module

4SCU18LT units contain a diagnostic module for troubleshooting air conditioning system failures. By monitoring and analyzing data from the compressor and thermostat demand, the module can accurately detect the cause of electrical and system related failure without any sensors. If a system problem occurs, a flashing LED indicator communicates the failure code.

LED Description

POWER LED (Green) indicates voltage is present at the power connection of the module.

ALERT LED (Yellow) communicates an abnormal system condition through a unique flash code. The ALERT LED will flash a number of times consecutively, pause, and then repeat the process. The number of consecutive flashes correlates to a particular abnormal condition.

TRIP LED (Red) indicates there is a demand signal from the thermostat but no current to the compressor is detected by the module. The TRIP LED typically indicates the compressor protector is open or may indicate missing supply power to the compressor.

Interpreting the Diagnostic LEDs

When an abnormal system condition occurs, the diagnostic module displays the appropriate ALERT and/or TRIP LED. The yellow ALERT LED will flash a number of times consecutively, pause, and then repeat the process. To identify a flash code number, count the number of consecutive flashes. Refer to Table 9 on page 18 and Table 10 on page 19 for information on the flash codes.

Every time the module powers up, the last ALERT LED flash code that occurred prior to shutdown is displayed for 60 seconds. The module will continue to display the previous flash code until the condition returns to normal or 24 VAC is removed from the module. TRIP and ALERT LEDs flashing at the same time means control circuit voltage is too low for operation.

24 VAC Power Wiring

The diagnostic module requires a constant nominal 24VAC power supply. The wiring to the module's R and C terminals must be directly from the indoor unit or thermostat.

Thermostat Demand Wiring

The diagnostic module requires a thermostat demand signal to operate properly. The thermostat demand signal input, labeled Y on the module, should always be connected to the compressor contactor coil so that when the coil is energized, the demand signal input is 24VAC. When the Coil is not energized, the demand signal input should be less than 0.5VAC.

Miswired Module Codes

Depending on the system configuration, some ALERT flash codes may not be active. The presence of safety switches affects how the system alerts are displayed by the module.

Miswiring the diagnostic module will cause false LED codes. Table 11 on page 19 describes LED operation when the module is miswired and what troubleshooting action is required to correct the problem.

Flash Codes

LED Status	Fault Description	Troubleshooting Information
POWER (Green)	Module has power	Supply voltage is present at module terminals
TRIP (Red)	Thermostat demand signal Y1 is present, but the compressor is not running	<ol style="list-style-type: none"> 1. Compressor protector is open <ul style="list-style-type: none"> * Check for high head pressure * Check compressor supply voltage 2. Outdoor unit power disconnect is open 3. Compressor circuit breaker or fuse(s) is open 4. Broken wire or connector is not making contact 5. Low pressure switch open if present in system 6. Compressor contactor has failed open
ALERT (Yellow) Flash Code 1	Long Run Time Compressor is running extremely long run cycles	<ol style="list-style-type: none"> 1. Low refrigerant charge 2. Evaporator blower is not running <ul style="list-style-type: none"> * Check blower relay coil and contacts * Check blower motor capacitor * Check blower motor for failure or blockage * Check evaporator blower wiring and connector * Check indoor blower control board * Check thermostat wiring for open circuit 3. Evaporator coil is frozen <ul style="list-style-type: none"> * Check for low suction pressure * Check for excessively low thermostat setting * Check evaporator airflow (coil blockages or return air filter) * Check ductwork or registers for blockage 4. Faulty metering device <ul style="list-style-type: none"> * Check TXV bulb installation (size, location, and contact) * Check if TXV/fixed orifice is stuck closed or defective 5. Condenser coil is dirty 6. Liquid line restriction (filter drier blocked if present in system) 7. Thermostat is malfunctioning <ul style="list-style-type: none"> * Check thermostat sub-base or wiring for short circuit * Check thermostat installation (location, level)
ALERT (Yellow) Flash Code 2	System Pressure Trip Discharge or suction pressure out of limits or compressor overloaded	<ol style="list-style-type: none"> 1. High head pressure <ul style="list-style-type: none"> * Check high pressure switch if present in system * Check if system is overcharged with refrigerant * Check for non-condensable in system 2. Condenser coil poor air circulation (dirty, blocked, damaged) 3. Condenser fan is not running <ul style="list-style-type: none"> * Check fan capacitor * Check fan wiring and connectors * Check fan motor for failure or blockage 4. Return air duct has substantial leakage 5. If low pressure switch present in system, check Flash Code 1 info

Table 9

Flash Codes (cont.)

LED Status	Fault Description	Troubleshooting Information
ALERT (Yellow) Flash Code 3	Short Cycling Compressor is running only briefly	<ol style="list-style-type: none"> 1. Thermostat demand signal is intermittent 2. Time delay relay or control board defective 3. If high pressure switch present, go to Flash Code 2 info 4. If low pressure switch present, go to Flash Code 1 info
ALERT (Yellow) Flash Code 4	Locked Rotor	<ol style="list-style-type: none"> 1. Run capacitor has failed 2. Low line voltage (contact utility if voltage at disconnect is low) * Check wiring connections 3. Excessive liquid refrigerant in compressor 4. Compressor bearings are seized * Measure compressor oil level
ALERT (Yellow) Flash Code 5	Open Circuit	<ol style="list-style-type: none"> 1. Outdoor unit power disconnect is open 2. Compressor circuit breaker or fuse(s) is open 3. Compressor contactor has failed open * Check compressor contactor wiring and connectors * Check for compressor contactor failure (burned, pitted, or open) * Check wiring and connectors between supply and compressor * Check for low pilot voltage at compressor contactor coil 4. High pressure switch is open and requires manual reset 5. Open circuit in compressor supply wiring or connections 6. Unusually long compressor protector reset time due to extreme ambient temperature 7. Compressor windings are damaged * Check compressor motor winding resistance
ALERT (Yellow) Flash Code 6	Open Start Circuit Current only in run circuit	<ol style="list-style-type: none"> 1. Run capacitor has failed 2. Open circuit in compressor start wiring or connections * Check wiring and connectors between supply and the compressor S terminal 3. Compressor start winding is damaged * Check compressor motor winding resistance
ALERT (Yellow) Flash Code 7	Open Run Circuit Current only in start circuit	<ol style="list-style-type: none"> 1. Open circuit in compressor run wiring or connections * Check wiring and connectors between supply and the compressor R terminal 2. Compressor run winding is damaged * Check compressor motor winding resistance
ALERT (Yellow) Flash Code 8	Welded Contactor Compressor always runs	<ol style="list-style-type: none"> 1. Compressor contactor has failed closed 2. Thermostat demand signal not connected to module
ALERT (Yellow) Flash Code 9	Low Voltage Control circuit less than 17VAC	<ol style="list-style-type: none"> 1. Control circuit transformer is overloaded 2. Low line voltage (contact utility if voltage at disconnect is low) * Check wiring conditions

Table 10

Miswired Module Troubleshooting

Miswired Module Indication	Recommended Troubleshooting Action
Green LED is not on, module does not power up.	Determine if both R and C module terminals are connected. Verify voltage is present at module's R and C terminals. Review 24VAC Power Wiring section on page 16 for R and C wiring.
Green LED intermittent, module powers up only when compressor runs.	Determine if R and Y terminals are wired in reverse. Verify module's R and C terminals have a constant source. Review 24VAC Power Wiring section on page 16 for R and C wiring.
TRIP LED is on but system and compressor check OK.	Verify Y terminal is connected to 24VAC at contactor coil. Verify voltage at contactor coils falls below 0.5VAC when off.
TRIP LED and ALERT LED flashing together.	Verify R and C terminals are supplied with 19-28VAC.
ALERT Flash Code 3 (Compressor Short Cycling) displayed incorrectly.	Verify Y terminal is connected to 24VAC at contactor coil. Verify voltage at contactor coil falls below 0.5VAC when off.
ALERT Flash Code 5, 6, or 7 (Open Circuit, Open Start Circuit, or Open Run Circuit) displayed incorrectly.	Check that compressor run and start wires are through module's current sensing holes. Verify Y terminal is connected to 24VAC at contactor coil. Verify voltage at contactor coil falls below 0.5VAC when off.
ALERT Flash Code 6 (Open Start Circuit) displayed for Code 7 (Open Run Circuit) or vice versa.	Check that compressor run and start wires are routed through correct module sensing holes.
ALERT Flash Code 8 (Welded Contactor) displayed incorrectly.	Determine if module's Y terminal is connected. Verify Y terminal is connected to 24VAC at contactor coil. Verify 24VAC is present across Y and C when thermostat demand signal is present. If not, R and C are reverse wired. Verify voltage at contactor coil falls below 0.5VAC when off. Review Thermostat Demand Wiring on page 16 for Y and C wiring.

Table 11

MAINTENANCE

⚠ WARNING

Before performing maintenance operations on system, turn the electric power to unit OFF at disconnect switch(es). Unit may have multiple power supplies. Electrical shock could cause personal injury or death.

Maintenance and service must be performed by a qualified installer or service agency.

At the beginning of each cooling season, the system should be checked as follows:

1. Clean and inspect condenser coil. Coil may be flushed with a water hose. Be sure the power is off before using water to clean the coil.
2. Outdoor fan motor is pre-lubricated and sealed. No further lubrication is needed.
3. Visually inspect connecting lines and coils for evidence of oil leaks.
4. Check wiring for loose connections.
5. Check for correct voltage at unit (with unit operating).
6. Check amp-draw outdoor fan motor.

Unit nameplate _____ Actual _____

NOTE: If owner complains of insufficient cooling, the unit should be gauged and refrigerant charge checked. Refer to the Refrigerant Charging section on page 12.

Indoor Coil

1. Clean coil, if necessary.
2. Check connecting lines and coils for evidence of oil leaks.
3. Check condensate pan line and clean, if necessary.

Indoor Unit

1. Clean or change filters.
2. Adjust blower speed for cooling. Measure the pressure drop over the coil to determine the correct blower CFM.
3. Belt drive blowers: Check belt for wear and proper tension.

4. Check all wiring for loose connections.
5. Check for correct voltage at unit (with unit operating).
6. Check amp-draw on blower motor.
Unit nameplate _____ Actual _____

Start-Up and Performance Checklist

Job Name _____ Job No. _____ Date _____

Job Location _____ City _____ State _____

Installer _____ City _____ State _____

Unit Model No. _____ Serial No. _____

Service Technician _____ Nameplate Voltage _____

Rated Load Ampacity _____ Compressor Amperage _____ Outdoor Fan _____

Maximum Fuse or Circuit Breaker _____

Electical Connections Tight? Indoor Filter Clean? Supply Voltage (Unit Off) _____

Indoor Blower RPM _____ S.P. Drop Over Indoor (Dry) _____

Outdoor Coil Entering Air Temperature _____ Voltage with Compressor Operating _____

Discharge Pressure _____ Vapor Pressure _____

Refrigerant Charge Checked? Outdoor Fan Checked?

Refrigerant Lines: Leak Checked? Properly Insulated?

Service Valves: Fully Opened? Caps Tight?

Thermostat: Calibrated? Properly Set? Level?

WIRE DIAGRAM

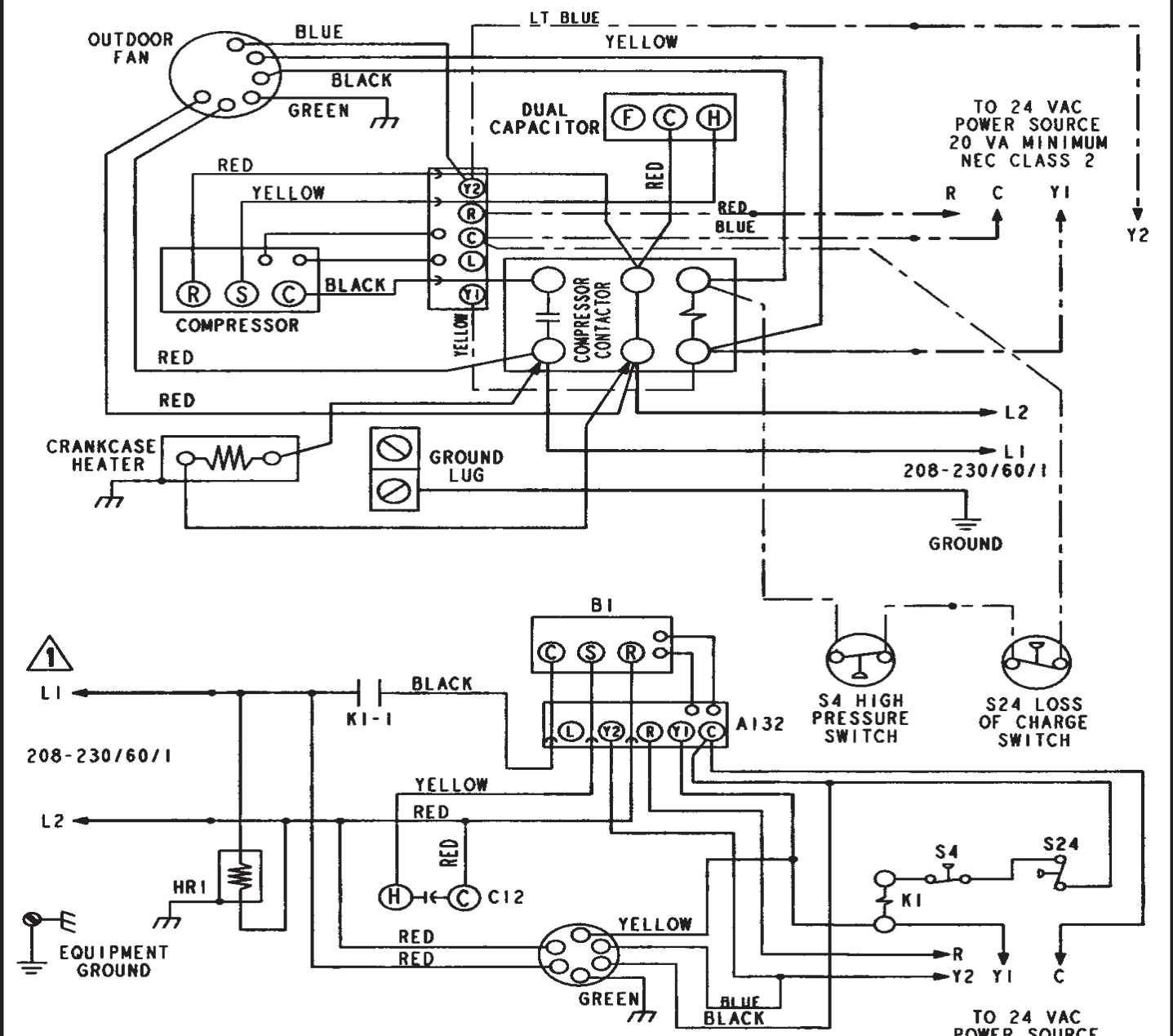

DESCRIPTION	
KEY	COMPONENT
A4	CONTROL - TIMED OFF
A132	DIAGNOSTIC MODULE
B1	COMPRESSOR
B4	MOTOR - OUTDOOR FAN
C12	CAPACITOR - DUAL
HR1	HEATER - COMPRESSOR
K1-1	CONTACTOR - COMPRESSOR
S4	SWITCH - HIGH PRESSURE
S24	SWITCH - LOSS OF CHARGE

⚠ FOR USE WITH COPPER CONDUCTORS ONLY. REFER TO UNIT RATING PLATE FOR MINIMUM CIRCUIT AMPACITY AND MAXIMUM OVERCURRENT PROTECTION SIZE.
WARNING--
 ELECTRIC SHOCK HAZARD. CAN CAUSE INJURY OR DEATH. UNIT MUST BE GROUNDED IN ACCORDANCE WITH NATIONAL AND LOCAL CODES.

← DENOTES OPTIONAL COMPONENTS

—— LINE VOLTAGE FIELD INSTALLED
 - - - CLASS II VOLTAGE FIELD INSTALLED
 - - - 24 VOLT FACTORY INSTALLED

48629-001

**ALLIED AIR ENTERPRISES
EQUIPMENT LIMITED WARRANTY
APPLIES IN U.S.A. AND CANADA ONLY
FAILURE TO MAINTAIN YOUR EQUIPMENT WILL VOID THIS WARRANTY**

COVERED EQUIPMENT

The following Allied Air Enterprises heating and cooling equipment is covered by the Limited Warranty.

Condensing Units: 2SCU13, 4SCU13, 4SCU14, 4SCU16, 4SCU18, 2AC13, 2AC14, 4AC13

Heat Pumps: 2SHP13, 4SHP13, 2SHP14, 4SHP14, 4SHP16, 4SHP18, 2HP13, 2HP14, 4HP13

Gas Furnaces: G1N80, G1D80, G2D80, G1D91, G1D93, G2D93, G2D95, FPBB, CG80, CG90, CG92, CG93

Oil Furnace: LBR80, LBF80, LHF80, LUF80, LHF80, RLUF, RLBF, RLBR, RLBU, RLHF, RLHR

Electric Furnace: EFC, EFV

Evaporator Coils: EC, EU, EH, EM

Air handlers: BCS2, RBCS2

Package Equipment: 2PCE13, 4PCE13, 4PCE15, 2PGE13, 4PGE13, 4PGE15, 2PHP13, 4PHP13, 4PHP15, 2SG13, 2SH13, 2SA13, RGE13, RPGE13, RHP13, RCE13, RPHP13, RPCE13

PARTS and COMPRESSOR COVERAGE

The covered equipment and covered parts and compressor are warranted by Allied Air for a period of five (5) years from the date of the original installation, when installed in a residential application (which includes homes, duplexes, apartments and condominiums). The covered equipment and covered parts and compressor are warranted by Allied Air for a period of one (1) year from the date of the original installation, when installed in non-residential applications. If, during this period, a covered component fails because of a manufacturing defect, Allied Air will provide a free replacement part to the owner through a licensed service contractor utilizing an Allied Air distributor. You must pay shipping charges and all other costs of warranty service. Allied Air will not pay labor involved in diagnostic calls or in removing, repairing, servicing or replacing parts. Such cost may be covered by a separate warranty provided by the installer.

HEAT EXCHANGER EXTENDED COVERAGE

All covered heat exchangers are warranted by Allied Air for a period of twenty (20) years from the date of original installation.

Heat Exchanger Availability: If a replacement heat exchanger is no longer available for a unit covered by this warranty, Allied Air will allow a credit toward the purchase of an equivalent Allied Air furnace (at the current suggested distributor's cost).

NOTE: If the date of original installation cannot be verified, the warranty period will be deemed to begin ninety (90) days after the date of manufacture.

EXCLUDED COMPONENTS

The following components are not covered by this warranty: cabinets, cabinet pieces, air filters, driers, refrigerant, refrigerant line sets, belts, wiring, fuses, oil nozzles, unit accessories and any parts not affecting unit operation

CARE OF EQUIPMENT

Your new Allied Air unit must be properly installed, operated and maintained in accordance with the unit installation, operation and maintenance instructions provided with each Allied Air unit. Failure to provide maintenance per Allied Air instructions will void this warranty.

WARRANTY PROCEDURE

When service or warranty parts are required:

1. Call your local licensed service dealer or contractor
2. If the installing dealer is unable to provide warranty service, check online at www.alliedair.com.
3. Be prepared to furnish the following information:
 - a. complete model and serial number
 - b. proof of required periodic maintenance, installation date and location
 - c. an accurate description of the problem

WARRANTY LIMITATIONS

1. This warranty is void if the covered equipment is removed from the original installation site.
2. This warranty does not cover damage or defect resulting from:
 - a. Flood, wind, fire, lightning, mold, or installation and operation in a corrosive atmosphere, or otherwise in contact with corrosive materials (chlorine, fluorine, salt, recycled waste water, urine, fertilizers, or other damaging substances or chemicals). Accident, or neglect or unreasonable use or operation of the equipment including operation of electrical equipment at voltages other than the range specified on the unit nameplate (includes damages caused by brownouts).
 - b. Modification, change or alteration of the equipment, except as directed in writing by Allied Air.
 - c. Operation with system components (indoor unit, outdoor unit and refrigerant control devices) which are not an ARI match or meet the specifications recommended by Allied Air.
 - d. Operation of furnaces with return air temperatures of less than 60°F (16°C) or operation of a furnace field installed downstream from a cooling coil.
 - e. Use of contaminated or refrigerant not compatible with the unit.

The installation of replacement parts under the terms of this warranty does not extend the original warranty period.

Allied Air makes no express warranties other than the warranty specified above. All implied warranties, including the implied warranties of merchantability and fitness for a particular purpose, are excluded to the extent to a period legally permissible. Should such exclusion or limitation of the warranty be unenforceable, such implied warranties are in any event limited to a period of one (1) year. Liability for incidental and consequential damages is excluded. Some states do not allow limitation of incidental damages, so the limitations or exclusions may not apply to you. Allied Air will not pay electricity or fuel costs, or increases in electricity or fuel costs, for any reason whatsoever, including additional or unusual use of supplemental electric heat. This warranty does not cover lodging expenses or labor charges.

Allied Air shall not be liable for any default or delay in performance under this warranty caused by any contingency beyond its control.

This warranty gives you specific legal rights, and you may also have other rights which vary from state to state.

NOTE TO CUSTOMER:

Please complete information below and retain this warranty for your records and future reference.

Outside Unit Model Number: _____ Serial Number: _____ Installed Date: _____

Furnace / Air Handler: _____ Serial Number: _____ Installed Date: _____

Indoor Coil Model Number: _____ Serial Number: _____ Installed Date: _____

Installing Company Name: _____ Phone: _____

Installing Company Address: _____ State/Province: _____ Zip/Postal Code: _____



215 Metropolitan Drive, West Columbia, SC 29170
© 2008 Allied Air Enterprises Litho U.S.A. FORM W-2008-2 (3/10/2009)

LIMITED EXTENDED PARTS WARRANTY

Allied Air Enterprises, Inc. ("Allied") provides its air conditioning and heating products with a standard five-year parts warranty. This limited extended parts warranty is in addition to and is intended to supplement Allied's standard 5-year parts warranty. As such, this limited extended warranty provides for a total of 10-years of limited warranty coverage (Standard 5-Year Limited Parts Warranty plus Additional 5-Year Limited Extended Parts warranty).

EXTENDED COVERAGE -

PARTS/COMPRESSORS

The covered equipment and parts are warranted by Allied for a total of **10 YEARS** (standard 5 Year Limited Parts Warranty) from installation, except as provided below.

HEAT EXCHANGERS

The covered residential heating equipment's heat exchanger is warranted by Allied for a Limited Lifetime (standard 20 Year Limited Warranty) from date of original installation, except as provided below.

This warranty applies only to the original purchaser of the unit and cannot be transferred. If during this period, a covered part fails because of a defect in materials or workmanship under normal use and maintenance, Allied will provide a free replacement part to the purchaser through an Armstrong Air, Air Ease, Ducane or Concord dealer or other licensed service contractor through an authorized Allied distributor. The purchaser must pay shipping costs, including labor, of the warranty service.

EXCLUDED COMPONENTS -

The following components are expressly not covered by this limited warranty: cabinets, cabinet pieces, air filters, driers, refrigerant, refrigerant line sets, belts, wiring, fuses, oil nozzles, and unit accessories, R-22 compressors, and any parts not affecting unit operation.

COVERAGE REQUIREMENTS -

1. The unit is an Armstrong Air, Air ease, Ducane, or Concord branded unit;
2. The unit is installed in a residential application, which is an owner-occupied single-family residence. No commercial applications are allowed;
3. **The unit is properly registered at (www.alliedair.com) with Allied Air Enterprises within 60-days after the original date of installation or occupancy.¹ To register follow the directions and complete the on line warranty registration at (www.alliedair.com). For customer inquiries contact Allied Air at 1-800-448-5872.**
4. The unit is part of a complete ARI matched system and installed by a state certified or licensed contractor in accordance with the unit installation, operation, and maintenance instructions provided with the unit.
5. Coils and air handlers are covered only when they are branded Armstrong Air, Air ease, Ducane, or Concord and are purchased and installed as a system along with a qualifying unit. (Third party coils are not covered).
6. Installation takes place on or after October 3, 2008.

If this extended warranty does not apply, then parts are warranted for the standard warranty period of **5 YEARS** and all heat exchangers for **20 YEARS**. If the standard warranty periods differ from the original warranty certificate, the periods stated on the original warranty certificate apply.

This limited extended warranty does not apply to, and no warranty is offered by Allied, on any unit ordered over the internet. Proof of purchase may be required.

Any part replaced pursuant to this limited extended warranty is warranted only for the unexpired portion of the limited extended warranty term applying to the original part. The installation of replacement parts under the terms of this limited extended warranty does not extend the warranty period.

This limited extended warranty is an extension of Allied's standard warranty. **ANY IMPLIED WARRANTY OF MERCHANTABILITY OR FITNESS FOR A PARTICULAR PURPOSE ON THIS PRODUCT IS LIMITED IN DURATION TO THE TERM OF THIS LIMITED EXTENDED WARRANTY.** Some states and provinces do not allow limitations on how long an implied warranty lasts, so the above limitation may not apply to you.

ALLIED SHALL IN NO EVENT BE LIABLE FOR INCIDENTAL OR CONSEQUENTIAL DAMAGES, INCLUDING BUT NOT LIMITED TO EXTRA UTILITY EXPENSES OR DAMAGES TO PROPERTY. Some states and provinces do not allow the exclusion or limitation of incidental or consequential damages, so the above limitation or exclusion may not apply to you.

Allied is not responsible for:

1. Damage or repairs required as a result of flood, fire, wind, lightning strike (to the home or unit), corrosive atmosphere, contact with corrosive material (Chlorine, fluorine, salt, recycled waste water, fertilizers or other damaging substances) or other conditions beyond the control of Allied;
2. Use of parts, accessories, or refrigerant not compatible with the unit;
3. Modification, change or alteration of the unit, except as expressly directed in writing by Allied;
4. Improper use, accident, neglect or unreasonable use or operation of the unit, including operation of electrical equipment at voltages other than the range specified on the unit nameplate;
5. Operation with system parts (indoor unit, outdoor unit and refrigerant control devices) which are not ARI matched or do not meet the specifications recommended by Allied;
6. Damage or repairs required as a consequence of faulty installation or application;
7. Normal maintenance as described in the installation and operating manual, such as cleaning of coils, filter cleaning and/or replacement and lubrication; and
8. Changes in the appearance or sound of the unit that do not affect its performance.

The parties intend this writing as a final expression of their agreement with respect to warranties. Allied makes no other warranty beyond that which is expressly contained in this writing.

Allied shall not be liable for any default or delay in performance under this warranty caused by any contingency beyond its control, including the unavailability of replacement parts.

This warranty gives you specific legal rights, and you may also have other rights that vary from state to state or province to province.

Steps for getting replacement parts under this limited extended warranty:

If you suspect a defect in your equipment, please contact the installer of the unit to obtain assistance. If unsuccessful, please contact an Allied dealer or distributor in your area. If unable to obtain local assistance, refer to Allied's website (www.alliedair.com) or contact Allied at 800-448-5872.

¹ Excludes residents of states or provinces where registration requirements are prohibited, such as California and Quebec. Residents of these states or provinces may either register as noted above or provide proof of when the unit was purchased and installed, such as an original invoice from the contractor with the Owner's name, address, purchase date, serial and model number.