

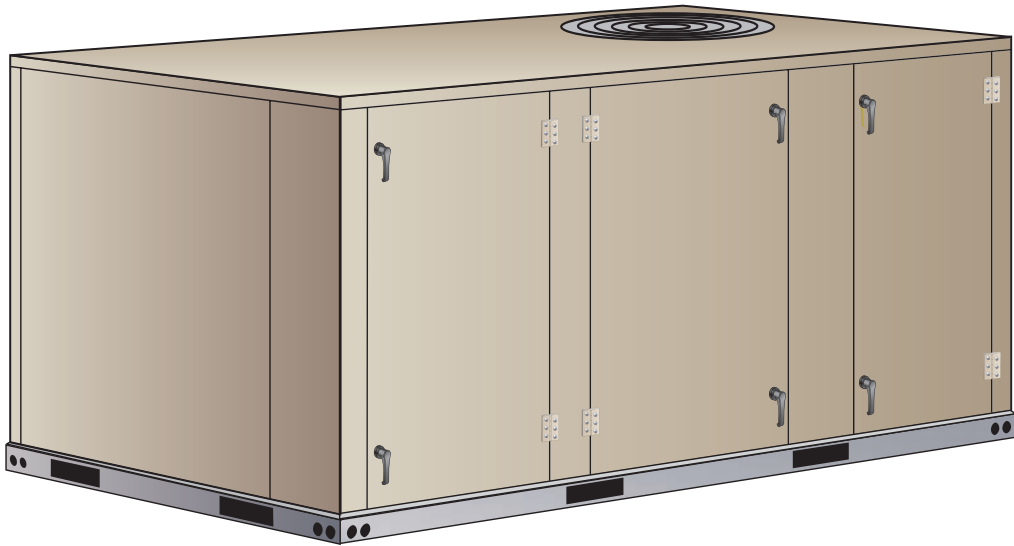

**COMMERCIAL
PRODUCT SPECIFICATIONS**



3 to 6 Tons
Net Cooling Capacity - 34,800 to 72,000 Btuh
Optional Electric Heat - 7.5 to 30 kW

MODEL NUMBER IDENTIFICATION

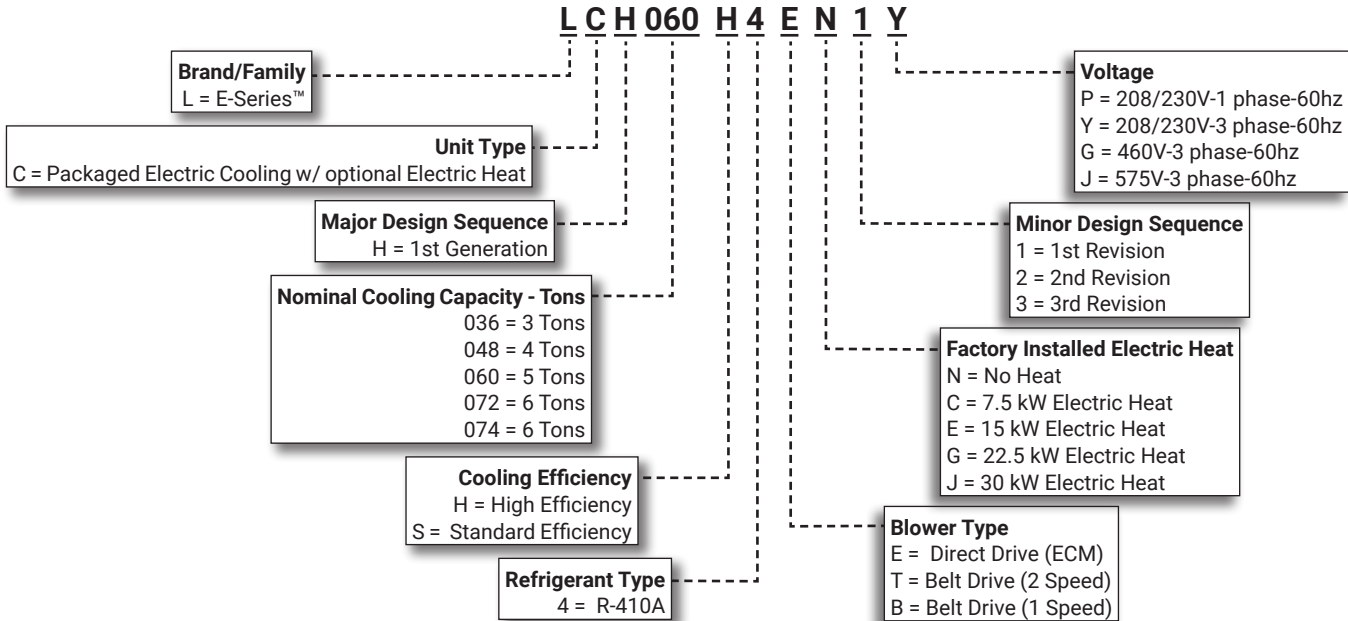

FEATURE HIGHLIGHTS

E-Series™ packaged rooftop unit product line was created to save energy with intelligence by offering some of the highest energy efficiency ratings available with a powerful, easy to use unit controller. This makes E-Series™ rooftop units perfect for business owners looking for an HVAC product with the lowest total cost of ownership.

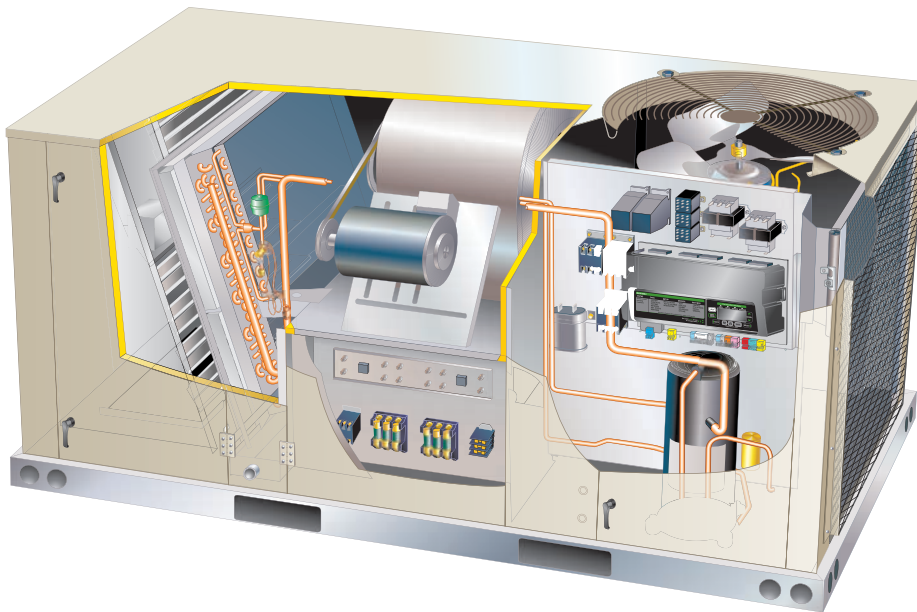

1. Two Stage Compressor
2. Filter/Drier
3. Eco-Last™ Coil System
4. Variable Speed Outdoor Coil Fan Motor
5. Heavy Gauge Steel Cabinet
6. Hinged Access Panels
7. Supply Air Blower
8. Electric Heat (option)
9. Air Filters
10. Intelli-Guide™ Control System
11. Economizer (option)

CONTENTS

Approvals And Warranty	3
Blower Data	29
Cooling Ratings	23
Dimensions - Unit	52
Electrical/Electric Heat Data	42
Electric Heat Capacities	50
Feature Highlights	2
Features And Benefits	3
Dehumidification System Option	11
Dehumidification System Ratings	27
Model Number Identification.	1
Optional Conventional Temperature Control Systems	12
Options / Accessories	17
Outdoor Sound Data	51
Sequence Of Operation.	14
Specifications	21
Unit Clearances	50
Weight Data	51

APPROVALS AND WARRANTY

APPROVALS

- AHRI Certified to AHRI Standard 210/240 (3 thru 5 ton models) and AHRI Standard 340/360 (6 ton models)
- ETL and CSA listed
- Efficiency rating certified by CSA
- Components bonded for grounding to meet safety standards for servicing required by UL, ULC and National and Canadian Electrical Codes
- All models are ASHRAE 90.1 compliant
- ENERGY STAR® certified units are designed to use less energy, help save money on utility bills, and help protect the environment
- ISO 9001 Registered Manufacturing Quality System

WARRANTY

- Compressors - Limited five years
- Eco-Last™ Coil System - Limited three years
- Intelli-Guide™ Unit Controller - Limited three years
- Optional High Performance Economizers - Limited five years
- All other covered components - Limited one year

FEATURES AND BENEFITS

COOLING SYSTEM

- Designed to maximize sensible and latent cooling performance at design conditions
- System can operate from 0°F to 125°F without any additional controls

R-410A Refrigerant

- Non-chlorine based
- Ozone friendly

1 Two-Stage Compressor (3 to 5 Ton and 6 Ton 074 Models)

- Scroll compressors on all models for high performance, reliability, and quiet operation
 - Two-stage scroll compressors are furnished on 3 to 5 ton and 6 ton 074 models for increased part load efficiency
 - Single speed scroll furnished on 6 ton 072 models
- Resiliently mounted on rubber grommets for quiet operation

Compressor Crankcase Heater

- Protects against refrigerant migration that can occur during low ambient operation or during extended off cycles

Thermal Expansion Valve

- Ensures optimal performance throughout the application range
- Removable element head

2 Filter/Drier

- High capacity filter/drier protects the system from dirt and moisture

High Pressure Switch

- Protects the compressor from overload conditions such as dirty condenser coils, blocked refrigerant flow, or loss of outdoor fan operation

Low Pressure Switch

- Protects the compressor from low pressure conditions such as low refrigerant charge, or low/no airflow

Freezestat

- Protects the evaporator coil from damaging ice build-up due to conditions such as low/no airflow, or low refrigerant charge

3 Condenser Coil - Eco-Last™ Coil System

- Condenser coil features lightweight, all aluminum brazed fin construction
- Constructed of three components: a flat extrusion tube, fins in-between the flat extrusion tube and two refrigerant manifolds

Eco-Last™ Coil System Features:

- Improved heat transfer performance due to high primary surface area (flat tubes) versus secondary surface (fins)
- Smaller internal volume (reduced refrigerant charge)
- High durability (all aluminum construction)
- Fewer brazed joints
- Compact design (reduces unit weight)
- Easy maintenance/cleaning
- Face-split design
- Mounting brackets with rubber inserts secure coil to unit providing vibration dampening and corrosion protection

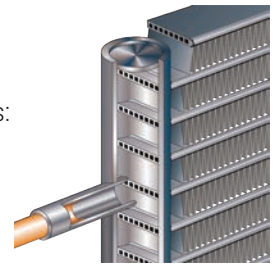

FEATURES AND BENEFITS

COOLING SYSTEM (continued)

Evaporator Coil

- Copper tube construction
- Enhanced rippled-edge aluminum fins
- Flared shoulder tubing connections
- Silver soldered construction for improved heat transfer
- Factory leak tested
- Cross row circuiting with rifled tubing optimizes both sensible and latent cooling capacity

Condensate Drain Pan

- Plastic pan, sloped to meet drainage requirements of ASHRAE 62.1
- Side or bottom drain connections
- Reversible to allow connection at back of unit

4 Variable Speed Outdoor Coil Fan Motor

- Variable speed (ECM) fan motor for energy efficient Single Zone VAV operation and quiet operation
- Thermal overload protected
- Totally enclosed
- Permanently lubricated ball bearings
- Shaft up
- Wire basket mount

Outdoor Coil Fan

- PVC coated fan guard furnished

Required Selections

Cooling Capacity

- Specify nominal cooling capacity

Cooling Efficiency (3 to 5 Ton models only)

- Specify either standard or high efficiency

Options/Accessories

Factory Installed

Conventional Fin/Tube Condenser Coil (replaces Eco-Last™ Coil System)

- Copper tube construction
- Enhanced rippled-edge aluminum fins
- Flared shoulder tubing connections
- Silver soldered construction

Service Valves

- Fully serviceable brass valves installed in discharge & liquid lines

NOTE - Not available for units equipped with Eco-Last™ Coil System or Dehumidification Option.

Factory or Field Installed

Condensate Drain Trap

- Field installed only
- May be factory enclosed to ship with unit
- Available in copper or PVC

Drain Pan Overflow Switch

- Monitors condensate level in drain pan
- Shuts down unit if drain becomes clogged

CABINET

5 Construction

- Heavy-gauge steel panels and full perimeter heavy-gauge galvanized steel base rail provides structural integrity for transportation, handling, and installation
- Base rails have rigging holes
- Three sides of the base rail have forklift slots
- Raised edges around duct and power entry openings in the bottom of the unit provide additional protection against water entering the building

Airflow Choice

- Units are shipped in downflow (vertical) configuration
- Can be field converted to horizontal airflow configuration without any optional kits

Duct Flanges

- Provided for horizontal duct attachment

Power Entry

- Electrical lines can be brought through the unit base or through horizontal access knock-outs

Exterior Panels

- Constructed of heavy-gauge, galvanized steel with a two-layer enamel paint finish

Insulation

- All panels adjacent to conditioned air are fully insulated with non-hygroscopic fiberglass insulation
- Unit base is fully insulated
- Insulation serves as an air seal to the roof curb, eliminating the need to add a seal during installation

6 Access Panels

- Hinged tool-less access panels are provided for the economizer/filter section, and compressor/controls section
- All hinged panels have seals and quarter-turn latching handles to provide a tight air and water seal

NOTE - Optional Economizers, Power Exhaust, Outdoor Air Dampers and Barometric Relief Dampers for 060/072/074 models include a filler panel for proper cabinet fit.

FEATURES AND BENEFITS

CABINET (continued)

Required Selections

Airflow Configuration

- Specify horizontal or downflow

Options/Accessories

Factory Installed

Corrosion Protection

- A completely flexible immersed coating with an electrodeposited dry film process (AST ElectroFin E-Coat)
- Meets Mil Spec MIL-P-53084, ASTM B117 Standard Method Salt Spray Testing
- Indoor Corrosion Protection:
 - Coated coil
 - Coated reheat coil (Dehumidification)
 - Painted blower housing
 - Painted base
- Outdoor Corrosion Protection:
 - Coated coil
 - Painted base

Field Installed

Combination Coil/Hail Guards

- Heavy gauge steel frame painted to match cabinet with expanded metal mesh to protect the outdoor coil from damage

BLOWER

- A wide selection of supply air blower options are available to meet a variety of airflow requirements

Blower Motor Choice

- Overload protected, equipped with ball bearings
- Variable-speed ECM direct drive motors are offered on 036, 048 and 060 models
- Belt drive motors with two-speed capability (low static/high static) are available on 036, 048, 060 and 074 models in several different sizes to maximize air performance
- Single speed belt drive motors are available in different sizes to meet static requirements on 072 models

7 Supply Air Blower

- Forward curved blades, blower wheel is statically and dynamically balanced
- All belt drive motors have adjustable pulley for speed change

Ordering Information

- Specify motor horsepower and drive kit number when base unit is ordered

Required Selections

- Order one drive kit, see Drive Kit Specifications Table

Options/Accessories

Factory Installed

Blower Belt Auto Tensioner

- Provides proper tension to belt drive blower belt without the need for regular adjustments
- Maintains airflow and proper performance

ELECTRICAL

WireRight™ System

- Advanced wiring connectors are keyed and color-coded to prevent miswiring
- Wire coloring scheme is standardized across all models
- Each connection is intuitively labeled to make troubleshooting and servicing quick and easy

Electrical Plugs

- Positive connection electrical plugs are used to connect common accessories or maintenance parts for easy removal or installation

Required Selections

Voltage Choice

- Specify when ordering base unit

Options/Accessories

Factory Installed

Circuit Breakers

- HACR type
- For overload and short circuit protection
- Factory wired and mounted in the power entry panel
- Current sensitive and temperature activated
- Manual reset

Phase/Voltage Detection (3 Phase models only)

- Monitors power supply to assure phase is correct at unit start-up
- If phase is incorrect, the unit will not start and an alarm code is reported to the unit controller
- Protects unit from being started with incorrect phasing which could lead to issues such as compressors running backwards
- Voltage detection monitors power supply voltage to assure proper voltage
- If voltage is not correct (over/under voltage conditions) the unit will not start and an alarm code is reported to the unit controller

NOTE - Phase/voltage detection is furnished when the Single Zone VAV option is ordered.

Short-Circuit Current Rating (SCCR)

- Higher short circuit protection up to 100kA

NOTE - Disconnect Switch is not available as an option with High SCCR option.

FEATURES AND BENEFITS

ELECTRICAL (continued)

Options/Accessories (continued)

Factory Installed (continued)

SCR (Silicon Controlled Rectifier) Electric Heat Control

- Modulates small, precise increments of power to the electric heat load eliminating temperature fluctuations associated with mechanical controls
- Almost instantaneous operation with no moving parts
- Zero-Cross (fast cycling) feature improves electric heater life with less contraction and expansion of the heating elements
- The SCR operates when there is no call for heat from the building control system or thermostat
- SCR air tempering is controlled by a secondary thermostat and remote duct sensor (ordered separately)
- A call for heat overrides the SCR and modulates the SCR to 100% heat output. A call for cooling overrides the SCR

NOTE - The SCR option is not available with 45 kW and 60 kW electric heat (208/230V) models.

NOTE - Blower Proving Switch is required and must be ordered separately for factory installation. See Controls in the Options/Accessories table.

NOTE - Available for use with conventional thermostat controls or Novar® control systems only.

Factory or Field Installed

Disconnect Switch

- Accessible from outside of unit
- Spring loaded weatherproof cover furnished

8 Electric Heat

- Helix wound nichrome elements
- Individual element limit controls
- Wiring harness
- Unit fuse block
- See Options / Accessories tables for ordering information

GFI Service Outlets (2)

- 115V ground fault circuit interrupter (GFCI) type
- Non-powered
- Field-wired

Field Installed

GFI Weatherproof Cover

- Single-gang cover
- Heavy-duty UV-resistant polycarbonate case construction
- Hinged base cover with gasket

INDOOR AIR QUALITY

9 Air Filters

- Disposable 2 inch filters furnished as standard

Options/Accessories

Factory or Field Installed

High Efficiency Air Filters

- Disposable MERV 8 or MERV 13 (Minimum Efficiency Reporting Value based on ASHRAE 52.2) efficiency 2-inch pleated filters

Field Installed

UVC Germicidal Lamps



- Germicidal lamps emit ultra-violet (UV-C) energy, which has been proven to be effective in reducing microbes such as viruses, bacteria, yeasts, and molds
 - This process either destroys the organism or controls its ability to reproduce
 - UV-C energy greatly reduces the growth and proliferation of mold and other bioaerosols (bacteria and viruses) on illuminated surfaces (particularly coil and drain pan)
 - Field installed in the blower/evaporator coil section
 - All necessary hardware for installation is included
 - Lamps operate on 110/230V, 1 phase power supply
- NOTE** - Step-down transformer must be field supplied when used with 460V and 575V rooftop units.
- Approved by ETL

Indoor Air Quality (CO₂) Sensors

- Monitors CO₂ levels
- Reports to the Intelli-Guide™ Unit Controller, which adjusts economizer dampers as needed

CONTROL SYSTEM

INTELLI-GUIDE™ CONTROL SYSTEM



10 The Intelli-Guide™ unit controller is a microprocessor-based controller that provides flexible control of all unit functions.

Features:

- LCD Display
- Easy to read menu (4 lines x 20 character display)
- Buttons for menu navigation during setup and diagnostic
- Menu navigation LEDs for Data, Setup, Service, Settings
- Main Menu and Help Buttons for quick navigation to home screen and built-in help functions
- Scroll, Value Adjustment Select and Save Buttons
- Setup menu ensures proper installation and simplified setup of the rooftop unit
- Profile setup copies key settings between units with the same configuration to reduce setup time
- USB port allows a technician to download and transfer unit information to help verify service was performed
- USB software updates on the Intelli-Guide™ Control System enhance functionality without the need to change components
- Unit Controller Software
- Unit self-test verifies individual critical component and system performance
- Economizer test function assures economizer is operating correctly
- Time Clock with Run-Time Information

Built-In Functions Include:

- Adjustable Blower On/Off Delay
- Built-in Control Parameter Defaults
- Compressor Time-Off Delay
- DDC Compatible
- Dirty Filter Switch Input
- Discharge Air Temperature Control
- Display/Sensor Readout
- Economizer Control Options (See Economizer / Exhaust Air / Outdoor Air sections)
- Fresh Air Tempering
- Over 100 diagnostic and status messages in English
- Exhaust Fan Control Modes for fresh air damper position
- Permanent Diagnostic Code Storage
- Field Adjustable Control Parameters (Over 200 settings)
- Indoor Air Quality Input (Demand Control Ventilation)
- Low Ambient Controls for cooling operation down to 0°F
- Gas Valve Time Delay Between First and Second Stage
- Minimum Compressor Run Time

- Network Capable (Can be daisy chained to other units or controls)
- Night Setback Mode
- Return Air Temperature Limit Control
- Safety Switch Input allows Controller to respond to a external safety switch trip
- Service Relay Output
- Smoke Alarm Mode has four choices (unit off, positive pressure, negative pressure, purge)
- Up to 2 heat/2 cool (standard Intelli-Guide™ unit controller thermostat input)
- Up to 3 cool with additional relay
- Up to 4 cool with room sensor or network operation
- “Strike Three” Protection
- Gas Reheat Control allows simultaneous heating and cooling operation for humidity control of process air applications such as supermarkets
- On Demand Dehumidification monitors and controls condenser hot gas reheat operation with dehumidification option
- Thermostat Bounce Delay
- Warm Up Mode Delay
- LED Indicators
- PC Interface connects the Intelli-Guide™ unit controller to a PC with the Unit Controller Software
- Room Sensor Operation controls temperature

Options/Accessories

Factory or Field Installed

Blower Proving Switch

- Monitors blower operation
- Shuts down unit if blower stops

Dirty Filter Switch

- Senses static pressure increase

Controls Options

Factory Installed

Airflow Control System (Available for 3, 4, and 5 Ton High Efficiency Models Equipped With a Direct Drive Blower and Economizer)

- Complete airflow management system that precisely controls the economizer damper for accurate ventilation
- Allows the installer to directly enter the design-specified supply air (blower) and outdoor air volume (economizer minimum position) parameters without the need to manually take measurements and adjust settings
- Monitors supply air volume and outside air volume as well as customizable diagnostics

CONTROL SYSTEM

INTELLI-GUIDE™ CONTROL SYSTEM (continued)

Controls Options (continued)

Factory or Field Installed

Fresh Air Tempering

- Used in applications with high outside air requirements
- Controller energizes the first stage heat as needed to maintain a minimum supply air temperature for comfort, regardless of the thermostat demand
- When ordered as a factory option, sensor ships with the unit for field installation

Smoke Detector

- Photoelectric type
- Installed in supply air section, return air section or both sections
- Available with power board and single sensor (supply or return) or power board and two sensors (supply and return)
- Power board located in unit control compartment

Interoperability via BACnet® or LonTalk® Protocols

- Communication compatible with third-party automation systems that support the BACnet Application Specific Controller device profile, LonMark® Space Comfort Controller functional profile, or LonMark Discharge Air Controller functional profile

Commercial Control Systems

After-Market DDC

- Novar® Unit Controller and options

Thermostats

- Control system and thermostat options
- After-Market unit controller options

Field Installed

General Purpose Control Kit

- Plug-in control provides additional analog and digital inputs/outputs for field installed options

Humidity Sensor Kit

- Humidity sensor required with factory installed Dehumidification Option or Supermarket reheat field selectable option

NOTE - Intelli-Guide™ Control System features vary with the type of rooftop unit in which the control is installed

OPTIONS / ACCESSORIES

ECONOMIZER

- 11 • Economizer operation is set and controlled by the Intelli-Guide™ Unit Controller
- Simple plug-in connections from economizer to unit controller for easy installation
- All E-Series™ rooftop units are equipped with factory installed CEC Title 24 approved sensors for outside, return and discharge air temperature monitoring

NOTE - Optional sensors may be used instead of unit sensors to determine whether outdoor air is suitable for free cooling. See Options/Accessories table.

Factory or Field Installed

High Performance Economizer

- Approved for California Title 24 building standards
- Low leakage dampers are Air Movement and Control Association International (AMCA) Class 1A Certified - Maximum 3 CFM per sq. ft. leakage at 1 in. w.g.
- ASHRAE 90.1 compliant
- Combination Outdoor Air Hood is furnished
- Factory installed Economizer can be ordered with three exhaust options:
 - Barometric Relief Dampers
 - Power Exhaust Fan

NOTE - See Power Exhaust Fan section for additional requirements.

- No Exhaust
- Field installed Economizer includes Barometric Relief Dampers with Combination Hood
- Barometric Relief Dampers allow relief of excess air
- Dampers prevent blow back and outdoor air infiltration during off cycle
- Bird screen furnished

NOTE - Barometric Relief Dampers are required when Economizer is factory installed with factory installed Power Exhaust Fan option. See Power Exhaust Fan section and Options/Accessories table.

- Demand Control Ventilation (DCV) ready using optional CO₂ sensors
- Horizontal Barometric Dampers are required for horizontal Economizer applications and must be ordered separately
- Gear-driven action
- High torque 24-volt
- Fully-modulating spring return damper motor
- Return air and outdoor air dampers
- Plug-in connections to unit
- Nylon bearings
- Enhanced neoprene blade edge seals
- Flexible stainless steel jamb seals to minimize air leakage

OPTIONS / ACCESSORIES

ECONOMIZER (continued)

Factory or Field Installed (continued)

NOTE - High Performance Economizers are not approved for use with enthalpy controls in Title 24 applications.

NOTE - The Free Cooling setpoint for Title 24 applications must be set based on the Climate Zone where the system is installed. See Section 140.4 "Prescriptive Requirements for Space Conditioning Systems" of the California Energy Commission's 2013 Building Energy Efficiency Standards.

NOTE - Refer to Installation Instructions for complete setup information.

Differential Sensible Control

- Factory setting
- Uses outdoor air and return air sensors that are furnished with the unit
- The Intelli-Guide™ unit controller compares outdoor air and return air and using setpoints
- Enables the economizer when the outdoor air temperature is below the configured setpoint and cooler than return air

NOTE - Differential Sensible Control can be configured in the field to provide Offset Differential Sensible Control or Single Sensible Control.

- In Offset Differential Sensible Control mode, the economizer is enabled if the temperature differential (offset) between outdoor air and return air reaches the configured setpoint
- In Single Sensible Control mode, the economizer is enabled when outdoor air temperature falls below the configured setpoint

Global Control

- The unit controller communicates with a DDC system with one global sensor (enthalpy or sensible) to determine whether outside air is suitable for free cooling on all units connected to the control system
- Sensor must be field provided

NOTE - Global control with enthalpy is not approved for Title 24 applications.

Single Enthalpy Temperature Control (Not for Title 24)

- Outdoor air enthalpy sensor enables Economizer if the outdoor enthalpy is less than the setpoint of the control

Differential Enthalpy Control (Not for Title 24)

- Order two Single Enthalpy Controls:
 - One is field installed in the return air section
 - One in the outdoor air section
- Allows the economizer control to select between outdoor air or return air, whichever has lower enthalpy

Field Installed

Building Pressure Control

- Maintains constant building pressure level
- Using differential pressure information between the outdoor air and the building air, the Intelli-Guide™ unit controller changes the economizer position to help maintain a constant building pressure

NOTE - Not available with Demand Control Ventilation (CO₂ Sensor).

Horizontal Barometric Relief Dampers

- For use when unit is configured for horizontal applications with an economizer
- Allows relief of excess air
- Blade type dampers prevent blow back and outdoor air infiltration during off cycle
- Field installed in return air duct
- Exhaust hood with bird screen furnished
- Requires Horizontal Economizer Conversion Kit

Horizontal Economizer Conversion Kit

- Insulated panel covers the bottom return air opening on the unit base to convert downflow economizer to horizontal air flow

OPTIONS / ACCESSORIES

EXHAUST

Factory or Field Installed

Power Exhaust Fan

- Installs internal to unit for downflow applications with economizer option
- Provides exhaust air pressure relief
- Interlocked to run when supply air blower is operating
- Fan runs when outdoor air dampers are 50% open (adjustable)
- Motor is overload protected
- Fan is 16 in. diameter
- Four fan blades
- 1/3 hp motor

NOTE - If Power Exhaust is field installed with a factory installed Economizer, the Economizer must be ordered with No Exhaust option. Barometric Relief Dampers must also be ordered separately for field installation.

NOTE - If Power Exhaust is factory installed with a factory installed Economizer, Barometric Relief Dampers must also be ordered separately for field installation.

OUTDOOR AIR

Factory or Field Installed

Outdoor Air Damper

- Downflow or Horizontal
- Linked mechanical dampers
- 0 to 25% (fixed) outdoor air adjustable
- Installs in unit
- Includes outdoor air hood
- Automatic model features fully modulating spring return damper motor with plug-in connection
- Manual model features parallel blade, gear-driven dampers with adjustable fixed position

ROOF CURBS

Field Installed

- Nailer strip furnished (downflow only)
- Mates to unit
- US National Roofing Contractors Approved
- Shipped knocked down

Hybrid Roof Curbs, Downflow

- Interlocking tabs fasten corners together
- No tools required
- Can also be fastened together with furnished hardware
- Available in 8, 14, 18, and 24 inch heights

Adjustable Pitch Curb

- Fully adjustable pitch curbs (3/4 in. per foot in any direction) provide a level platform for rooftop units allowing flexible installations on roofs with uneven or sloped angles
- Uses interlocking tabs to fasten corners together; no tools required
- Hardware is furnished to connect upper curb with lower curb
- Available in 14 inch height

Adaptor Curbs (not shown)

- Curbs are regionally sourced
- Dimensions vary based upon the source

NOTE - Contact your local sales representative for a detailed cut sheet with applicable dimensions.

CEILING DIFFUSERS

Field Installed

Ceiling Diffusers

(Flush or Step-Down)

- White powder coat finish on diffuser face and grilles
- Insulated UL listed duct liner
- Diffuser box has collars for duct connection
- Step-down diffusers have double deflection blades
- Flush diffusers have fixed blades
- Provisions for suspending
- Internally sealed to prevent recirculation
- Removable return air grille
- Adapts to T-bar ceiling grids or plaster ceilings

Transitions (Supply and Return)

- Used with diffusers
- Installs in roof curb
- Galvanized steel construction
- Flanges furnished for duct connection to diffusers
- Fully insulated

DEHUMIDIFICATION SYSTEM OPTION

OVERVIEW

- Factory installed option designed to control humidity
- Provides dehumidification on demand using ASHRAE 90.1 recommended method for comfort conditioning humidity control
- Unit comes equipped with one row reheat coil, solenoid valve and humidity controller
- A thermostat with a dehumidification output, a dehumidistat, or a DDC controller with an isolated output is required to control humidity and must be located in the occupied space

BENEFITS

- Improves indoor air quality
- Helps prevent damage due to high humidity levels
- Improves comfort levels by reducing space humidity levels

OPERATION

No Dehumidification Demand

- The unit will operate conventionally whenever there is a demand for cooling or heating and no dehumidification demand
- Free cooling is only permitted when there is no demand for dehumidification

Dehumidification Demand Only

- The Unit Controller is factory set at 60% relative humidity setpoint and can be adjusted at the Unit Controller or with optional Unit Controller Software
- Reheat operation will initiate on a dehumidification demand and does not require a cooling demand
- The unit will operate in the dehumidification mode until the relative humidity of the conditioned space is below the setpoint
- The reheat coil is sized to provide 68°F to 75°F supply air during reheat operation
- This reduces sensible cooling capacity and extends compressor run time to control humidity when the cooling load is low
- A solenoid valve diverts hot gas from the compressor to the reheat coil
- The cooled and dehumidified air from the evaporator is reheated as it passes through the reheat coil
- The de-superheated and partially condensed refrigerant continues to the outdoor condenser coil where condensing is completed
- Unit will continue to operate in this mode until the dehumidification demand is satisfied

NOTE - See Sequence of Operation for additional information.

Dehumidification and Cooling Demand (Thermostat/Room Sensor Application)

Two-stage compressor models (036, 048, 060, 074)

- If both a dehumidification and a 1st stage cooling demand occur, the system will operate in the full cooling mode at first stage indoor air flow. If a 2nd stage cooling demand occurs along with a dehumidification demand, the system operates in full cooling mode at full cooling airflow until the 2nd stage cooling demand is satisfied
- Then the system will revert to the dehumidification mode if a dehumidification mode demand is present

Single speed compressor model (072H)

- If both a dehumidification and a cooling demand occur, the system will operate in cooling until the cooling demand is satisfied; then the system will energize the dehumidification mode

Options/Accessories

Humidity Sensor Kit

- Remote mounted dehumidistat for factory installed Dehumidification option or Supermarket reheat field selectable option

NOTE - A thermostat with a dehumidification output or a DDC controller with an isolated output can be used instead.

TYPICAL DEHUMIDIFICATION SCHEMATIC

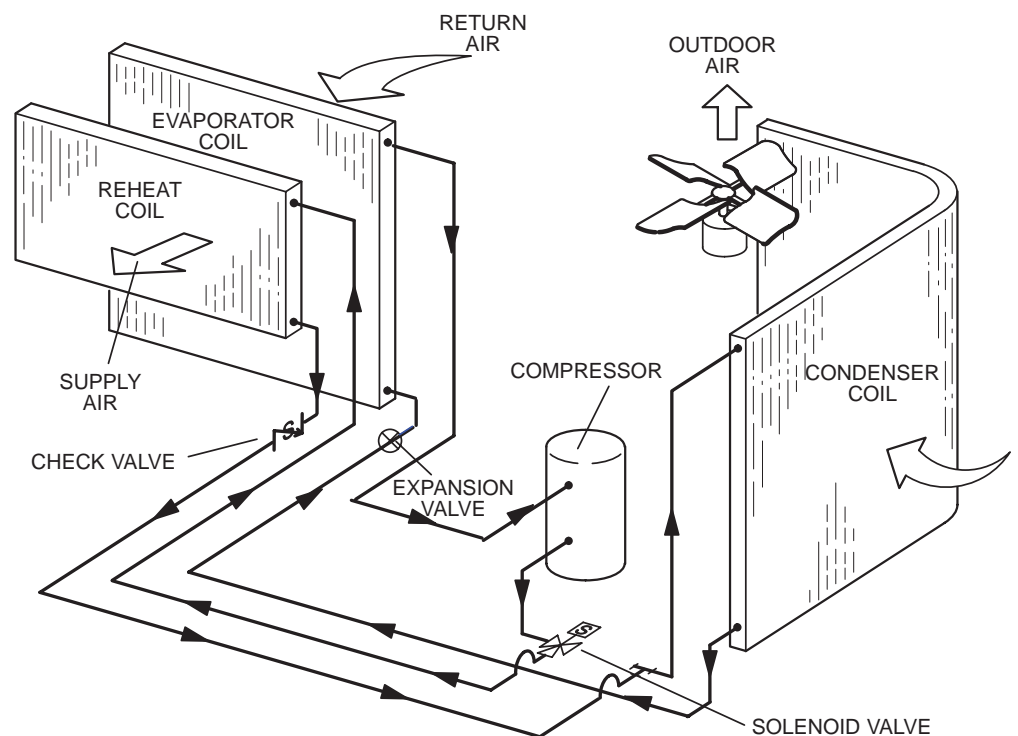

THIS PAGE INTENTIONALLY LEFT BLANK

THIS PAGE INTENTIONALLY LEFT BLANK

Objective: Outline the unit functions as a result of room thermostat or zone sensor demands.

Given: When economizer is present, it will function as initial part of the unit cooling system. When not present, unit will function as if outdoor ambient is high and sensed as not suitable.

DIRECT DRIVE AND BELT DRIVE SYSTEM OPERATION (3 THROUGH 5 TONS AND 6 TON 074 MODELS):

NOTE - Direct drive units feature ECM condenser fans that are staged to match the compressor's capacity. When the compressor is operating at first stage, the condenser fan is operating at low speed. The condenser fan switches to high speed when the compressor switches to second stage to match operation.

Modulating Outdoor Air Damper:

Damper minimum positions #1 and 2 are adjusted during unit setup to provide minimum fresh air requirements at the indicated supply fan speeds per ASHRAE 62.1.

- Supply fan is off and the outdoor air damper is closed
- Supply fan is on low speed and the outdoor air damper is at minimum position 1
- Supply fan is on high speed and the outdoor air damper is at minimum position 2

¹ Unit Features an Economizer and Outdoor Air is Suitable

Cooling - Thermostat or Zone Sensor Mode (Up to 3 stages Y1, Y2, Y3)

Y1 Demand:

Compressor is off, supply fan is on low speed, economizer modulates (minimum to maximum open position) to maintain 55°F supply air temperature (default unit controller setting)

After 5 minutes (default unit controller setting), supply fan switches to high speed. Economizer continues modulating with supply fan on high speed to maintain 55°F supply air temperature

Y2 Demand:

Compressor is off, supply fan is on high speed, and economizer modulates to maintain 55°F supply air temperature

Economizer opens to maximum. If economizer stays at maximum open for 3 minutes (default unit controller setting) compressor is energized and operates at first stage while supply fan stays on high speed

¹ Outdoor air suitability is determined by the energy state of outdoor ambient (enthalpy or sensible) and its ability to achieve the desired free cooling effects. Outdoor air suitability can also be determined by a third party controller and provided to the RTU via a network connection.

Y3 Demand:

Economizer is at maximum open and compressor operates at first stage. If economizer stays at maximum open for 3 minutes (default unit controller setting) compressor switches to second stage operation while supply fan stays on high speed

Unit Does Not Feature an Economizer (or Outdoor Air Is Not Suitable)

Cooling - Thermostat or Zone Sensor (Up to 2 stages Y1, Y2)

Y1 Demand:

Compressor operates at first stage and supply fan operates at low speed

Y2 Demand:

Compressor operates at second stage and supply fan operates at high speed

(Continued on Next Page)

DIRECT DRIVE AND BELT DRIVE SYSTEM OPERATION (3 THROUGH 5 TONS AND 6 TON 074 MODELS) (CONTINUED)

Dehumidification Mode (economizer free cooling is locked out):

Unit Features the Dehumidification option.

No Y1, Y2 Demand but a call for dehumidification:

Compressor operates at second stage, supply fan operates at low speed, and the reheat valve is energized

Y1 Demand:

Compressor operates at second stage, outdoor fan operates at high speed, supply fan operates at low speed and the reheat valve is de-energized

Y2 Demand:

Compressor operates at second stage, supply fan operates at high speed, and the reheat valve is de-energized

Heating Mode: Thermostat or Zone Sensor (1 stage W1)

W1 Demand:

Electric Heat is energized and the supply fan operates at high speed

SINGLE STAGE UNIT OPERATION (6 TON 072 MODELS)**Modulating Outdoor Air Damper:**

Damper minimum positions are adjusted during unit setup to provide minimum fresh air requirements at the indicated supply fan speeds per ASHRAE 62.1.

- Supply fan is off and the outdoor air damper is closed
- Supply fan is on and the outdoor air damper is at minimum position

¹ Unit Features an Economizer and Outdoor Air is Suitable

Cooling - Thermostat or Zone Sensor (Up to 2 stages Y1, Y2)

Y1 Demand:

Compressor is off, supply fan is on, economizer modulates (minimum to maximum open position) to maintain 55°F supply air temperature (default unit controller setting)

Y2 Demand:

Economizer goes to maximum open position and if the damper stays open for three minutes (default unit controller setting) the compressor is energized

Unit Does Not Feature an Economizer (or outdoor air is not suitable)

Cooling - Thermostat or Zone Sensor (Up to 1 stage Y1)

Y1 Demand:

Compressor is operating and supply fan is on

Dehumidification Mode (economizer free cooling is locked out):**Unit Features Dehumidification System****No Y1 Demand but a call for dehumidification:**

Compressor is operating, supply fan is on, and the reheat valve is energized

Y1 Demand:

Compressor is operating, supply fan is on, and the reheat valve is de-energized

Y2 Demand:

Compressor is operating, supply fan is on, and the reheat valve is de-energized

Heating Mode: Thermostat or Zone Sensor (1 stage W1)**W1 Demand:**

Electric Heat is energized and the supply fan operates at high speed

OPTIONS / ACCESSORIES

Item	Model Number	Catalog Number	Unit Model Number					
			036	048	060	072	074	
COOLING SYSTEM								
Condensate Drain Trap	PVC - C1TRAP20AD2	76W26	OX	OX	OX	OX	OX	
	Copper - C1TRAP10AD2	76W27	OX	OX	OX	OX	OX	
Conventional Fin/Tube Condenser Coil (replaces Eco-Last™ Coil System)		Factory	O	O	O	O	O	
Drain Pan Overflow Switch	E1SNSR71AD1	68W88	OX	OX	OX	OX	OX	
Efficiency	Standard	Factory	O	O	O			
	High	Factory	O	O	O	O	O	
Service Valves (not for Eco-Last™ Coil System or Dehumidification Option)		Factory	O	O	O	O	O	
BLOWER - SUPPLY AIR								
Motors	Direct Drive - 0.50 hp	Factory	O					
	Direct Drive - 0.75 hp	Factory		O				
	Direct Drive - 1 hp	Factory			O			
	Belt Drive - .75 hp (2 Speed)	Factory	O	O				
	Belt Drive - 1 hp (2 Speed)	Factory	O		O		O	
	Belt Drive - 2 hp (2 Speed)	Factory		O	O		O	
	Belt Drive - 1 hp Standard Efficiency	Factory					O	
	Belt Drive - 2 hp Standard Efficiency	Factory					O	
	Drive Kits See Blower Data Tables for selection	Kit A01 - T1DRKT001-1 - 673-1010 rpm	Factory	O				
		Kit A02 - T1DRKT002-1 - 745-1117 rpm	Factory		O			
Kit A03 - T1DRKT003-1 - 833-1250 rpm		Factory			O			
Kit A05 - T1DRKT005-1 - 897-1346 rpm		Factory	O					
Kit A06 - T1DRKT006-1 - 1071-1429 rpm		Factory		O				
Kit A07 - T1DRKT007-1 - 1212-1548 rpm		Factory			O			
Kit AA01 - T1DRKT001AP1 - 522-784 rpm		Factory					O O	
Kit AA02 - T1DRKT002AP1 - 632-875 rpm		Factory					O O	
Kit AA03 - T1DRKT003AP1 - 798-1105 rpm		Factory					O O	
Blower Belt Auto-Tensioner		Factory	O	O	O	O	O	
CABINET								
Combination Coil/Hail Guards	C1GARD51A-1	13R98	X	X				
	C1GARD51AT1	13T03			X	X	X	
Corrosion Protection (indoor coil / outdoor coil)		Factory	O	O	O	O	O	
CONTROLS								
Blower Proving Switch	C1SNSR35FF1	53W65	OX	OX	OX	OX	OX	
Commercial Controls	CPC Einstein Integration	Factory	O	O	O	O	O	
	Intelli-Guide™ Control System - BACnet® Module - C0CTRL60AE1L	59W51	OX	OX	OX	OX	OX	
	Intelli-Guide™ Control System - LonTalk® Module - C0CTRL65FF1	54W27	OX	OX	OX	OX	OX	
	Novar® LSE	Factory	O	O	O	O	O	
Dirty Filter Switch	E1SNSR55AP1	53W66	OX	OX	OX	OX	OX	
General Purpose Control Kit	E1GPBK30C1	13J78	X	X	X	X	X	
Fresh Air Tempering	C1SNSR75AD1	58W63	OX	OX	OX	OX	OX	
¹ Airflow Control System (Supply and Ventilation Airflow Control)		Factory	O	O	O			
Smoke Detector - Supply or Return (Power board and one sensor)	C1SNSR44AP1	53W78	OX	OX	OX	OX	OX	
Smoke Detector - Supply and Return (Power board and two sensors)	C1SNSR43AP1	53W79	OX	OX	OX	OX	OX	

¹ Available for 3, 4 and 5 ton high efficiency models equipped with direct drive blower and Economizer.

NOTE - Catalog and model numbers shown are for ordering field installed accessories.

OX = Configure To Order (Factory Installed) or Field Installed

O = Configure To Order (Factory Installed)

X = Field Installed

OPTIONS / ACCESSORIES

Item	Model Number	Catalog Number	Unit Model Number				
			036	048	060	072	074
ELECTRICAL							
Voltage	208/230V - 1 phase	Factory	¹ O	¹ O	¹ O		
60 hz	208/230V - 3 phase	Factory	O	O	O	O	O
	460V - 3 phase	Factory	O	O	O	O	O
	575V - 3 phase	Factory	O	O	O	O	O
	HACR Circuit Breakers	Factory	O	O	O	O	O
Disconnect Switch (See Electrical / Electric Heat Tables for selection)	80 amp - T2DISC080AH1	20W21	OX	OX			
	150 amp - T2DISC150AH1	20W22		OX			
	80 amp T2DISC080NH1	20W24			OX	OX	OX
	150 amp - T2DISC150NH1	20W25			OX	OX	OX
² Short-Circuit Current Rating (SCCR) of 100kA (includes Phase/Voltage Detection)		Factory	O	O	O	O	O
GFI Service Outlets	15 amp non-powered, field-wired (208/230V, 460V only) LTAGFIK10/15	74M70	OX	OX	OX	OX	OX
	20 amp non-powered, field-wired (575V only) C1GFCI20FF1	67E01	OX	OX	OX	OX	OX
Weatherproof Cover for GFI	C1GFCI99FF1	10C89	X	X	X	X	X
Phase/Voltage Detection - 3 Phase Models Only		Factory	O	O	O	O	O

¹ 208/230-1ph not available on belt drive units.

² Disconnect Switch not available with higher SCCR option.

ELECTRIC HEAT

7.5 kW	208/230V-1ph - E1EH0075AN1P	46W28	OX	OX	OX		
	208/230V-3ph - E1EH0075AN1Y	46W31	OX	OX	OX	OX	OX
	460V-3ph - E1EH0075AN1G	46W35	OX	OX	OX	OX	OX
	575V-3ph - E1EH0075AN1J	46W39	OX	OX	OX	OX	OX
15 kW	208/230V-1ph - E1EH0150AN1P	46W29	OX	OX	OX		
	208/230V-3ph - E1EH0150AN1Y	46W32	OX	OX	OX	OX	OX
	460V-3ph - E1EH0150AN1G	46W36	OX	OX	OX	OX	OX
	575V-3ph - E1EH0150AN1J	46W40	OX	OX	OX	OX	OX
22.5 kW	208/230V-1ph - E1EH0225N1P	46W30			OX		
	208/230V-3ph - E1EH0225N1Y	46W33			OX	OX	OX
	460V-3ph - E1EH0225N1G	46W37			OX	OX	OX
	575V-3ph - E1EH0225N1J	46W41			OX	OX	OX
30 kW	208/230V-3ph - E1EH0300N-1Y	46W34				OX	OX
	460V-3ph - E1EH0300N-1G	46W38				OX	OX
	575V-3ph - E1EH0300N-1J	46W42				OX	OX
SCR (Silicon Controlled Rectifier) Electric Heat Control		Factory	O	O	O	O	O
Thermostat (required)		Y9682	X	X	X	X	X
Duct Sensor (required)		Y9683	X	X	X	X	X

NOTE - Catalog and model numbers shown are for ordering field installed accessories.

OX - Configure To Order (Factory Installed) or Field Installed

O = Configure To Order (Factory Installed)

X = Field Installed

OPTIONS / ACCESSORIES

Item	Model Number	Catalog Number	Unit Model Number				
			036	048	060	072	074
ECONOMIZER							
High Performance Economizer With Outdoor Air Hood (Sensible Control) (Approved for California Title 24 Building Standards / AMCA Class 1A Certified)							
High Performance Economizer - Includes Barometric Relief Dampers and Combination Hood	E1ECON17A-1	10U54	OX	OX	OX	OX	OX
Economizer Accessories							
Horizontal Economizer Conversion Kit	T1HECK00AN1	17W45	X	X	X	X	X
Economizer Controls							
Differential Enthalpy (Not for Title 24)	Order 2 - C1SNSR64FF1	53W64	OX	OX	OX	OX	OX
Sensible Control	Sensor is Furnished	Factory	O	O	O	O	O
Single Enthalpy (Not for Title 24)	C1SNSR64FF1	53W64	OX	OX	OX	OX	OX
Global Control	Sensor Field Provided	Factory	O	O	O	O	O
Building Pressure Control	E1GPBK20C1	13J77	X	X	X	X	X
POWER EXHAUST FAN (DOWNFLOW ONLY)							
Standard Static	208/230V-1 or 3ph - C1PWRE10A-1P	79W87	OX	OX	OX	OX	OX
<i>NOTE - Factory or Field installed Power Exhaust Fan requires "Barometric Relief Dampers for Power Exhaust Kit" for field installation. See below.</i>	460V-3ph - C1PWRE10A-1G	79W88	OX	OX	OX	OX	OX
	575V-3ph - C1PWRE10A-1J	79W89	OX	OX	OX	OX	OX
BAROMETRIC RELIEF							
¹ Barometric Relief Dampers for Power Exhaust Kit	C1DAMP50A-3-	19D42	X	X	X	X	X
² Horizontal Barometric Relief Dampers With Exhaust Hood	LAGEDH03/15-2	19F01	X	X	X	X	X
¹ Required when Economizer is factory installed with factory installed Power Exhaust Fan option.							
² Required when Economizer is configured for horizontal airflow.							
OUTDOOR AIR							
Outdoor Air Dampers With Outdoor Air Hood							
Motorized	C1DAMP21A-1	15D17	OX	OX	OX	OX	OX
Manual	C1DAMP11A-2	15D18	OX	OX	OX	OX	OX
CONDENSER REHEAT OPTION							
Dehumidification Option	Factory		O	O	O	O	O
Humidity Sensor Kit, Remote mounted (required)	C0SNSR31AE-1	17M50	X	X	X	X	X
INDOOR AIR QUALITY							
Air Filters							
High Efficiency Air Filters Order 4 per unit	MERV 8 (16 x 20 x 2 in.) - C1FLTR15A-1-	54W20	OX	OX			
	MERV 13 (16 x 20 x 2 in.) - T1FLTR40A-1-	52W37	OX	OX			
	MERV 8 (20 x 20 x 2 in.) - C1FLTR15D-1-	54W21			OX	OX	OX
	MERV 13 (20 x 20 x 2 in.) - C1FLTR40D-1-	52W39			OX	OX	OX
Replaceable Media Filter With Metal Mesh	16 x 20 x 2 in. (Order 4) - K1FLTR30A-1	39W09	X	X			
Frame (includes non-pleated filter media)	20 x 20 x 2 in. (Order 4) - K1FLTR30A-2	44N60			X	X	X
Replaceable Media Filter With Metal Mesh	16 x 20 x 2 in. (Order 4) - K1FLTR30A-1	39W09	X	X			
Frame (includes non-pleated filter media)	20 x 20 x 2 in. (Order 4) - K1FLTR30A-2	44N60			X	X	X
NOTE - Catalog and model numbers shown are for ordering field installed accessories.							
OX = Configure To Order (Factory Installed) or Field Installed							
O = Configure To Order (Factory Installed)							
X = Field Installed							

OPTIONS / ACCESSORIES

Item	Model Number	Catalog Number	Unit Model Number				
			036	048	060	072	074
INDOOR AIR QUALITY (CO₂) SENSORS							
Sensor - Wall-mount, off-white plastic cover with LCD display	C0SNSR50AE1L	77N39	X	X	X	X	X
Sensor - Wall-mount, off-white plastic cover, no display	C0SNSR52AE1L	87N53	X	X	X	X	X
Sensor - Black plastic case with LCD display, rated for plenum mounting	C0SNSR51AE1L	87N52	X	X	X	X	X
Sensor - Wall-mount, black plastic case, no display, rated for plenum mounting	C0MISC19AE1	87N54	X	X	X	X	X
CO ₂ Sensor Duct Mounting Kit - for downflow applications	C0MISC19AE1-	85L43	X	X	X	X	X
Aspiration Box - for duct mounting non-plenum rated CO ₂ sensors (87N53 or 77N39)	C0MISC16AE1-	90N43	X	X	X	X	X
UVC GERMICIDAL LAMPS							
¹ UVC Light Kit (208/230V-1ph)	C1UVCL10AN1-	50W90	X	X	X	X	X
¹ Lamps operate on 110-230V single-phase power supply. Step-down transformer may be ordered separately for 460V and 575V units. Alternately, 110V power supply may be used to directly power the UVC ballast(s)							
ROOF CURBS							
Hybrid Roof Curbs, Downflow							
8 in. height	C1CURB70A-1	11F50	X	X	X	X	X
14 in. height	C1CURB71A-1	11F51	X	X	X	X	X
18 in. height	C1CURB72A-1	11F52	X	X	X	X	X
24 in. height	C1CURB73A-1	11F53	X	X	X	X	X
Transition Curb							
CEILING DIFFUSERS							
Step-Down - Order one	RTD9-65S	13K60	X	X	X		
	RTD11-95S	13K61				X	X
Flush - Order one	FD9-65S	13K55	X	X	X		
	FD11-95S	13K56				X	X
Transitions (Supply and Return) - Order one	T1TRAN10AN1	17W53	X	X	X		
	T1TRAN20N-1	17W54				X	X

NOTE - Catalog and model numbers shown are for ordering field installed accessories.

OX - Configure To Order (Factory Installed) or Field Installed

O = Configure To Order (Factory Installed)

X = Field Installed

SPECIFICATIONS		DIRECT DRIVE		
General Data	Nominal Tonnage	3 Ton	4 Ton	5 Ton
	Model Number	LCH036H4E	LCH048H4E	LCH060H4E
	Efficiency Type	High	High	High
	Blower Type	Multi-Speed Direct Drive	Multi-Speed Direct Drive	Multi-Speed Direct Drive
Cooling Performance	Gross Cooling Capacity - Btuh	36,600	50,100	61,600
	¹ Net Cooling Capacity - Btuh	36,000	49,000	60,000
	AHRI Rated Air Flow - cfm	1200	1600	1750
	Total Unit Power - kW	2.8	3.8	4.7
	¹ SEER (Btuh/Watt) - 208/230V-1-3ph	18.0	17.6	17.1
	¹ SEER (Btuh/Watt) - 460V-3ph, 575V-3ph	17.0	17.0	17.0
	¹ EER (Btuh/Watt) - 208/230V-1-3ph	12.8	12.8	12.7
	¹ EER (Btuh/Watt) - 460V-3ph, 575V-3ph	12.5	12.8	12.7
Refrigerant Charge	Refrigerant Type	R-410A	R-410A	R-410A
	Eco-Last™ Coil System	4 lbs. 5 oz.	6 lbs. 4 oz.	8 lbs. 0 oz.
	Conventional Fin/Tube Coil	8 lbs. 8 oz.	11 lbs. 2 oz.	14 lbs. 0 oz.
	Eco-Last™ Coil System With Dehumidification Option	5 lbs. 2 oz.	6 lbs. 8 oz.	8 lbs. 0 oz.
	Conventional Fin/Tube With Dehumidification Option	9 lbs. 3 oz.	12 lbs. 4 oz.	16 lbs. 0 oz.
Electric Heat Available - See Page 18		7.5 and 15 kW	7.5 and 15 kW	7.5, 15 and 22.5 kW
Compressor Type (one per unit)		Two-Stage Scroll	Two-Stage Scroll	Two-Stage Scroll
Outdoor Coil Eco-Last™ (Fin/Tube)	Net face area (total) - sq. ft.	11.70 (15.60)	14.50 (15.60)	17.80 (19.30)
	Tube diameter - in.	0.71 (3/8)	0.71 (3/8)	0.71 (3/8)
	Number of rows	1 (1.5)	1 (2)	1 (2)
	Fins per inch	20 (20)	20 (20)	20 (20)
Outdoor Coil Fans	Motor - (No.) horsepower	(1) 1/3 (ECM)	(1) 1/3 (ECM)	(1) 1/3 (ECM)
	Motor rpm	715-810	645-810	930-1100
	Total Motor Input - watts	112-160	89-165	230-350
	Diameter - (No.) in.	(1) 24	(1) 24	(1) 24
	Number of blades	3	3	3
	Total air volume - cfm	3400-3795	2910-3675	4315-4980
	Indoor Coil	Net face area (total) - sq. ft.	7.78	7.78
Tube diameter - in.		3/8	3/8	3/8
Number of rows		3	4	4
Fins per inch		14	14	14
Drain connection (Number) and size - in.		(1) 1 NPT	(1) 1 NPT	(1) 1 NPT
Expansion device type		Balanced Port Thermostatic Expansion Valve, removable power head		
³ Indoor Blower	Nominal motor HP	0.50 (ECM)	0.75 (ECM)	1 (ECM)
	Blower wheel nominal diameter x width - in.	(1) 10 X 10	(1) 10 X 10	(1) 11 X 10
Filters	Type of filter	disposable		
	Number and size - in.	(4) 16 X 20 X 2		(4) 20 x 20 x 2
Electrical characteristics		208/230V - 60 hz - 1 phase 208/230V, 460V, or 575V - 60 hz -3 phase		

NOTE - Net capacity includes evaporator blower motor heat deduction. Gross capacity does not include evaporator blower motor heat deduction.

¹ AHRI Certified to AHRI Standard 210/240: 95°F outdoor air temperature and 80°F db/67°F wb entering evaporator air; minimum external duct static pressure.

² Using total air volume and system static pressure requirements determine from blower performance tables rpm and motor output required. Maximum usable output of motors furnished are shown. In Canada, nominal motor output is also maximum usable motor output. If motors of comparable output are used, be sure to keep within the service factor limitations outlined on the motor nameplate.

SPECIFICATIONS

BELT DRIVE

General Data		Nominal Tonnage	3 Ton	4 Ton	5 Ton	6 Ton	6 Ton	
Model Number			LCH036S4T	LCH048S4T	LCH060S4T	LCH072H4B	LCH074H4T	
Efficiency Type			Standard	Standard	Standard	High	High	
Blower Type			Two Speed Belt Drive	Two Speed Belt Drive	Two Speed Belt Drive	Single Speed Belt Drive	Two Speed Belt Drive	
Cooling Performance	Gross Cooling Capacity - Btuh		35,800	49,100	61,600	73,500	72,000	
	Net Cooling Capacity - Btuh		¹ 34,800	¹ 48,000	¹ 60,000	² 72,000	² 69,000	
	AHRI Rated Air Flow - cfm		1200	1600	1750	1920	2100	
	Total Unit Power - kW		3.0	3.9	4.8	6.0	5.7	
	SEER (Btuh/Watt)		¹ 15.0	¹ 15.0	¹ 15.5	---	---	
	EER (Btuh/Watt)		¹ 11.6	¹ 11.6	¹ 12.3	² 12.0	² 12.0	
IEER (Btuh/Watt)			---	---	---	² 13.5	² 16.0	
Refrigerant Charge	Refrigerant Type		R-410A	R-410A	R-410A	R-410A	R-410A	
	Eco-Last™ Coil System		4 lbs. 5 oz.	6 lbs. 4 oz.	8 lbs. 0 oz.	7 lbs. 8 oz.	7 lbs. 2 oz.	
	Conventional Fin/Tube Coil		8 lbs. 8 oz.	11 lbs. 2 oz.	14 lbs. 0 oz.	13 lbs. 12 oz.	13 lbs. 11oz	
	Eco-Last™ Coil System With Dehumidification		5 lbs. 2 oz.	6 lbs. 8 oz.	8 lbs. 0 oz.	9 lbs. 0 oz.	8 lbs. 15 oz.	
	Conventional Fin/Tube With Dehumidification		9 lbs. 3 oz.	12 lbs. 4 oz.	16 lbs. 0 oz.	15 lbs. 3 oz.	15 lbs. 11oz	
Electric Heat Available - See Page 18			7.5 and 15 kW	7.5 and 15 kW	7.5, 15 and 22.5 kW	7.5, 15, 22.5 and 30 kW	7.5, 15, 22.5 and 30 kW	
Compressor Type (one per unit)			Two-Stage Scroll	Two-Stage Scroll	Two-Stage Scroll	Scroll	Two-Stage Scroll	
Outdoor Coil (Fin/Tube)	Net face area (total) - sq. ft.		11.70 (15.60)	14.5 (15.60)	17.80 (19.30)	17.80 (19.30)	17.80 (19.30)	
	Tube diameter - in.		0.71 (3/8)	0.71 (3/8)	0.71 (3/8)	0.71 (3/8)	0.71 (3/8)	
	Number of rows		1 (1.5)	1 (2)	1 (2)	1 (2)	1 (2)	
	Fins per inch		20 (20)	20 (20)	20 (20)	20 (20)	20 (20)	
Outdoor Coil Fans	Motor - (No.) horsepower		(1) 1/6 (PSC)	(1) 1/4 (PSC)	(1) 1/3 (PSC)	(1) 1/3 (PSC)	(1) 1/3 (PSC)	
	Motor rpm		825	825	1075	1075	1075	
	Total Motor Input - watts		168	230	410	410	375	
	Diameter - (No.) in.		(1) 24	(1) 24	(1) 24	(1) 24	(1) 24	
	Number of blades		3	3	3	3	3	
	Total air volume - cfm		3000	3300	4800	4800	4800	
Indoor Coil	Net face area (total) - sq. ft.		7.78	7.78	9.72	9.72	9.72	
	Tube diameter - in.		3/8	3/8	3/8	3/8	3/8	
	Number of rows		3	4	4	4	4	
	Fins per inch		14	14	14	14	14	
	Drain connection (Number) and size - in.		(1) 1 NPT	(1) 1 NPT	(1) 1 NPT	(1) 1 NPT	(1) 1 NPT	
Expansion device type			Balanced Port Thermostatic Expansion Valve, removable power head					
Indoor Blower and Drive Selection	No. of Speeds		2	2	2	1	2	
	Nominal motor HP	Low static	0.75	0.75	1	1	1	
		High static	1	2	2	2	2	
	Maximum usable motor output (US Only)	Low static	0.86	0.86	1.15	1.15	1.15	
		High static	1.15	2.3	2.3	2.3	2.3	
	Motor - Drive kit number	A01		A01	A02	A03	AA01	AA01
		low 449-673		low 497-673	low 555-833	522 - 784 rpm	522-784 rpm	522-784 rpm
high 673-1010			high 745-1117	high 833-1250	AA02	AA02	AA02	
A05			A06	A07	632 - 875 rpm	632-875 rpm	632-875 rpm	
low 598-897		low 714-953	low 808-1032	AA03	AA03	AA03		
high 897-1346		high 1071-1429	high 1212-1548	798 - 1105 rpm	798-1105 rpm	798-1105 rpm		
Blower wheel nominal diameter x width - in.		(1) 10 X 10	(1) 10 X 10	(1) 10 X 10	(1) 15 X 9	(1) 15 X 9		
Filters	Type of filter		disposable					
	Number and size - in.		(4) 16 X 20 X 2		(4) 20 X 20 X 2			
Electrical characteristics			208/230V, 460V, or 575V - 60 hz - 3 phase					

NOTE - Net capacity includes evaporator blower motor heat deduction. Gross capacity does not include evaporator blower motor heat deduction.

^{1,2}AHRI Certified to AHRI Standard ¹ 210/240 or ² 340/360: 95°F outdoor air temperature and 80°F db/67°F wb entering evaporator air; minimum external duct static pressure.

³ Using total air volume and system static pressure requirements determine from blower performance tables rpm and motor output required. Maximum usable output of motors furnished are shown. In Canada, nominal motor output is also maximum usable motor output. If motors of comparable output are used, be sure to keep within the service factor limitations outlined on the motor nameplate.

COOLING RATINGS

NOTE - For Temperatures and Capacities not shown in tables, see bulletin - Cooling Unit Rating Table Correction Factor Data in Miscellaneous Product Data section.

5 TON STANDARD EFFICIENCY LCH060S4 (1ST STAGE)

Entering Wet Bulb Temperature	Total Air Volume	Outdoor Air Temperature Entering Outdoor Coil																			
		65°F					75°F					85°F					95°F				
		Total Cool Cap.	Comp. Motor Input	Sensible To Total Ratio (S/T)			Total Cool Cap.	Comp. Motor Input	Sensible To Total Ratio (S/T)			Total Cool Cap.	Comp. Motor Input	Sensible To Total Ratio (S/T)			Total Cool Cap.	Comp. Motor Input	Sensible To Total Ratio (S/T)		
				Dry Bulb					Dry Bulb					Dry Bulb					Dry Bulb		
cfm	kBtuh	kW	75°F	80°F	85°F	kBtuh	kW	75°F	80°F	85°F	kBtuh	kW	75°F	80°F	85°F	kBtuh	kW	75°F	80°F	85°F	
63°F	1070	48	1.76	0.66	0.78	0.92	46.1	2.08	0.66	0.8	0.94	44.1	2.42	0.68	0.81	0.96	42.1	2.79	0.69	0.84	0.99
	1335	50.8	1.75	0.7	0.85	1	48.8	2.07	0.71	0.88	1	46.7	2.41	0.73	0.9	1	44.4	2.78	0.74	0.93	1
	1600	53	1.74	0.75	0.93	1	50.8	2.06	0.76	0.95	1	48.6	2.4	0.78	0.97	1	46.1	2.77	0.8	1	1
67°F	1070	51.2	1.75	0.53	0.64	0.74	49	2.06	0.53	0.64	0.76	46.9	2.41	0.53	0.65	0.78	45.1	2.78	0.54	0.67	0.79
	1335	54.1	1.73	0.55	0.67	0.81	52	2.06	0.56	0.69	0.83	49.7	2.4	0.57	0.7	0.86	47.4	2.78	0.58	0.72	0.88
	1600	56.4	1.72	0.58	0.72	0.89	54	2.05	0.58	0.73	0.91	51.6	2.39	0.57	0.75	0.93	49	2.77	0.6	0.78	0.97
71°F	1070	54.4	1.73	0.41	0.51	0.61	52.3	2.05	0.41	0.51	0.62	50	2.4	0.4	0.51	0.62	47.7	2.77	0.41	0.52	0.64
	1335	57.5	1.72	0.41	0.54	0.65	55.2	2.05	0.42	0.55	0.67	52.7	2.39	0.42	0.55	0.68	50.2	2.77	0.43	0.56	0.69
	1600	59.8	1.71	0.43	0.56	0.69	57.4	2.04	0.43	0.57	0.71	54.6	2.39	0.42	0.57	0.72	51.9	2.76	0.44	0.59	0.75

5 TON STANDARD EFFICIENCY LCH060S4 (2ND STAGE)

Entering Wet Bulb Temperature	Total Air Volume	Outdoor Air Temperature Entering Outdoor Coil																			
		85°F					95°F					105°F					115°F				
		Total Cool Cap.	Comp. Motor Input	Sensible To Total Ratio (S/T)			Total Cool Cap.	Comp. Motor Input	Sensible To Total Ratio (S/T)			Total Cool Cap.	Comp. Motor Input	Sensible To Total Ratio (S/T)			Total Cool Cap.	Comp. Motor Input	Sensible To Total Ratio (S/T)		
				Dry Bulb					Dry Bulb					Dry Bulb					Dry Bulb		
cfm	kBtuh	kW	75°F	80°F	85°F	kBtuh	kW	75°F	80°F	85°F	kBtuh	kW	75°F	80°F	85°F	kBtuh	kW	75°F	80°F	85°F	
63°F	1600	59.5	3.42	0.69	0.84	0.98	56.9	3.84	0.71	0.86	1	54.1	4.33	0.73	0.89	1	51	4.89	0.75	0.92	1
	2000	62.6	3.46	0.75	0.93	1	59.7	3.87	0.77	0.95	1	56.6	4.36	0.78	0.98	1	53.3	4.92	0.82	1	1
	2400	64.9	3.48	0.8	0.99	1	62.1	3.9	0.83	1	1	59.5	4.39	0.85	1	1	56.4	4.97	0.89	1	1
67°F	1600	62.9	3.46	0.55	0.67	0.8	60.3	3.88	0.56	0.69	0.82	57.4	4.37	0.57	0.7	0.85	54	4.93	0.58	0.72	0.88
	2000	66.3	3.5	0.59	0.73	0.88	63.3	3.92	0.6	0.74	0.91	60	4.4	0.6	0.76	0.94	56.6	4.97	0.62	0.79	0.98
	2400	68.4	3.52	0.61	0.77	0.96	65.3	3.94	0.63	0.8	0.99	61.8	4.42	0.64	0.82	1	58.1	4.98	0.65	0.86	1
71°F	1600	66.9	3.5	0.42	0.53	0.65	63.9	3.92	0.43	0.54	0.66	60.8	4.41	0.43	0.56	0.68	57.4	4.98	0.43	0.57	0.7
	2000	70	3.54	0.44	0.57	0.7	66.8	3.96	0.44	0.58	0.72	63.4	4.44	0.44	0.59	0.73	59.7	5.01	0.45	0.6	0.76
	2400	72.2	3.57	0.44	0.6	0.75	69	3.99	0.44	0.61	0.78	65.2	4.47	0.47	0.63	0.8	61.5	5.03	0.46	0.64	0.83

5 TON HIGH EFFICIENCY LCH060H4 (1ST STAGE)

Entering Wet Bulb Temperature	Total Air Volume	Outdoor Air Temperature Entering Outdoor Coil																			
		65°F					75°F					85°F					95°F				
		Total Cool Cap.	Comp. Motor Input	Sensible To Total Ratio (S/T)			Total Cool Cap.	Comp. Motor Input	Sensible To Total Ratio (S/T)			Total Cool Cap.	Comp. Motor Input	Sensible To Total Ratio (S/T)			Total Cool Cap.	Comp. Motor Input	Sensible To Total Ratio (S/T)		
				Dry Bulb					Dry Bulb					Dry Bulb					Dry Bulb		
cfm	kBtuh	kW	75°F	80°F	85°F	kBtuh	kW	75°F	80°F	85°F	kBtuh	kW	75°F	80°F	85°F	kBtuh	kW	75°F	80°F	85°F	
63°F	1070	47.4	1.82	0.66	0.79	0.92	45.5	2.14	0.67	0.8	0.94	43.5	2.49	0.68	0.82	0.97	41.5	2.87	0.7	0.85	0.99
	1335	50.1	1.81	0.71	0.85	1	48.2	2.13	0.72	0.88	1	46	2.48	0.73	0.91	1	43.7	2.86	0.75	0.93	1
	1600	52.3	1.8	0.75	0.93	1	50	2.13	0.77	0.95	1	47.9	2.48	0.79	0.98	1	45.5	2.86	0.8	1	1
67°F	1070	50.4	1.81	0.53	0.64	0.75	48.5	2.13	0.53	0.65	0.76	46.2	2.48	0.53	0.65	0.78	44.2	2.86	0.55	0.67	0.8
	1335	53.3	1.8	0.55	0.68	0.82	51.2	2.13	0.57	0.69	0.84	49	2.48	0.57	0.71	0.86	46.7	2.86	0.58	0.72	0.89
	1600	55.6	1.79	0.58	0.72	0.89	53.2	2.12	0.59	0.73	0.91	50.8	2.48	0.57	0.76	0.94	48.2	2.86	0.61	0.78	0.97
71°F	1070	53.6	1.8	0.41	0.51	0.62	51.5	2.12	0.41	0.52	0.62	49.3	2.47	0.41	0.52	0.63	47	2.86	0.42	0.53	0.65
	1335	56.7	1.79	0.42	0.54	0.66	54.4	2.12	0.43	0.55	0.67	51.9	2.47	0.43	0.56	0.68	49.5	2.86	0.43	0.57	0.7
	1600	58.9	1.78	0.43	0.57	0.7	56.5	2.12	0.44	0.58	0.71	53.9	2.47	0.44	0.58	0.72	51.2	2.86	0.45	0.6	0.75

5 TON HIGH EFFICIENCY LCH060H4 (2ND STAGE)

Entering Wet Bulb Temperature	Total Air Volume	Outdoor Air Temperature Entering Outdoor Coil																			
		85°F					95°F					105°F					115°F				
		Total Cool Cap.	Comp. Motor Input	Sensible To Total Ratio (S/T)			Total Cool Cap.	Comp. Motor Input	Sensible To Total Ratio (S/T)			Total Cool Cap.	Comp. Motor Input	Sensible To Total Ratio (S/T)			Total Cool Cap.	Comp. Motor Input	Sensible To Total Ratio (S/T)		
				Dry Bulb					Dry Bulb					Dry Bulb					Dry Bulb		
cfm	kBtuh	kW	75°F	80°F	85°F	kBtuh	kW	75°F	80°F	85°F	kBtuh	kW	75°F	80°F	85°F	kBtuh	kW	75°F	80°F	85°F	
63°F	1600	59.5	3.5	0.69	0.84	0.99	56.9	3.93	0.71	0.86	1	54	4.42	0.73	0.89	1	50.9	4.99	0.75	0.93	1
	2000	62.6	3.54	0.75	0.93	1	59.7	3.96	0.77	0.95	1	56.5	4.45	0.79	0.98	1	53.3	5.02	0.82	1	1
	2400	64.9	3.56	0.8	1	1	62.2	3.99	0.83	1	1	59.4	4.49	0.85	1	1	56.3	5.07	0.9	1	1
67°F	1600	63	3.54	0.54	0.67	0.8	60.2	3.97	0.56	0.68	0.82	57.3	4.46	0.57	0.7	0.85	53.9	5.03	0.58	0.72	0.88
	2000	66.4	3.58	0.59	0.73	0.89	63.2	4.01	0.59	0.74	0.92	59.7	4.5	0.6	0.76	0.94	56.4	5.07	0.62	0.79	0.98
	2400	68.4	3.61	0.61	0.78	0.97	65.2	4.03	0.63	0.8	0.99	61.6	4.52	0.64	0.83	1	58	5.09	0.65	0.87	1
71°F	1600	66.8	3.59	0.42	0.53	0.64	63.9	4.01	0.42	0.54	0.66	60.8	4.51	0.43	0.56	0.68	57.3	5.08	0.44	0.57	0.7
	2000	70.1	3.63	0.43	0.57	0.7	66.8	4.05	0.44	0.58	0.72	63.2	4.54	0.44	0.58	0.74	59.6	5.12	0.44	0.6	0.76
	2400	72.3	3.65	0.45	0.6	0.76	68.8	4.08	0.45	0.61	0.77	65.2	4.57	0.46	0.63	0.8	61.4	5.14	0.46	0.65	0.84

COOLING RATINGS

NOTE - For Temperatures and Capacities not shown in tables, see bulletin - Cooling Unit Rating Table Correction Factor Data in Miscellaneous Product Data section.

6 TON HIGH EFFICIENCY LCH072H4

Entering Wet Bulb Temperature	Total Air Volume	Outdoor Air Temperature Entering Outdoor Coil																			
		85°F					95°F					105°F					115°F				
		Total Cool Cap.	Comp. Motor Input	Sensible To Total Ratio (S/T)			Total Cool Cap.	Comp. Motor Input	Sensible To Total Ratio (S/T)			Total Cool Cap.	Comp. Motor Input	Sensible To Total Ratio (S/T)			Total Cool Cap.	Comp. Motor Input	Sensible To Total Ratio (S/T)		
				Dry Bulb					Dry Bulb					Dry Bulb					Dry Bulb		
cfm	kBtuh	kW	75°F	80°F	85°F	kBtuh	kW	75°F	80°F	85°F	kBtuh	kW	75°F	80°F	85°F	kBtuh	kW	75°F	80°F	85°F	
63°F	1920	72.3	4.53	0.71	0.85	0.99	69.1	5.05	0.73	0.87	1	65.7	5.63	0.74	0.9	1	61.8	6.28	0.76	0.93	1
	2400	76.2	4.55	0.76	0.93	1	72.8	5.06	0.78	0.96	1	69	5.63	0.8	0.98	1	64.9	6.28	0.82	1	1
	2880	79	4.56	0.82	1	1	75.6	5.06	0.84	1	1	72.5	5.64	0.86	1	1	68.8	6.31	0.9	1	1
67°F	1920	76.7	4.55	0.56	0.68	0.81	73.3	5.05	0.57	0.69	0.83	69.9	5.64	0.58	0.72	0.86	66	6.29	0.59	0.73	0.89
	2400	80.8	4.56	0.59	0.74	0.89	77.2	5.07	0.6	0.75	0.92	73.2	5.65	0.62	0.77	0.95	68.9	6.3	0.63	0.8	0.98
	2880	83.6	4.57	0.63	0.79	0.97	79.7	5.07	0.63	0.81	0.99	75.8	5.65	0.65	0.84	1	71	6.3	0.66	0.87	1
71°F	1920	81.6	4.56	0.43	0.55	0.66	78.1	5.07	0.43	0.55	0.67	74.4	5.65	0.43	0.56	0.69	70.1	6.3	0.44	0.58	0.71
	2400	85.7	4.58	0.44	0.58	0.71	81.8	5.08	0.45	0.59	0.73	77.7	5.66	0.45	0.6	0.75	73.1	6.31	0.46	0.62	0.77
	2880	88.4	4.59	0.46	0.61	0.77	84.4	5.09	0.46	0.62	0.79	80	5.67	0.46	0.63	0.8	75.5	6.32	0.47	0.65	0.84

6 TON HIGH EFFICIENCY LCH074H4 (1ST STAGE)

Entering Wet Bulb Temperature	Total Air Volume	Outdoor Air Temperature Entering Outdoor Coil																			
		65°F					75°F					85°F					95°F				
		Total Cool Cap.	Comp. Motor Input	Sensible To Total Ratio (S/T)			Total Cool Cap.	Comp. Motor Input	Sensible To Total Ratio (S/T)			Total Cool Cap.	Comp. Motor Input	Sensible To Total Ratio (S/T)			Total Cool Cap.	Comp. Motor Input	Sensible To Total Ratio (S/T)		
				Dry Bulb					Dry Bulb					Dry Bulb					Dry Bulb		
cfm	kBtuh	kW	75°F	80°F	85°F	kBtuh	kW	75°F	80°F	85°F	kBtuh	kW	75°F	80°F	85°F	kBtuh	kW	75°F	80°F	85°F	
63°F	1200	53.3	2.27	0.68	0.81	0.92	51	2.59	0.69	0.82	0.94	48.3	2.95	0.77	0.83	0.96	45.6	3.36	0.71	0.85	0.98
	1600	57.8	2.26	0.74	0.88	1	55.2	2.58	0.75	0.9	1	52.5	2.94	0.77	0.92	1	49.3	3.36	0.78	0.95	1
	2000	61.2	2.25	0.8	0.96	1	58.2	2.57	0.81	0.98	1	55.3	2.94	0.83	1	1	52.5	3.35	0.84	1	1
67°F	1200	57.2	2.26	0.55	0.66	0.77	54.7	2.58	0.55	0.67	0.78	51.9	2.94	0.55	0.67	0.79	48.9	3.36	0.55	0.68	0.81
	1600	61.9	2.25	0.58	0.72	0.85	59.2	2.57	0.59	0.73	0.86	56.3	2.93	0.59	0.74	0.88	53	3.35	0.6	0.76	0.91
	2000	65.4	2.24	0.62	0.78	0.93	62.3	2.56	0.62	0.78	0.94	59.2	2.93	0.63	0.8	0.97	55.6	3.34	0.64	0.82	0.99
71°F	1200	61.2	2.25	0.43	0.53	0.63	58.6	2.57	0.42	0.53	0.64	55.8	2.93	0.42	0.53	0.64	52.6	3.35	0.41	0.53	0.65
	1600	66.3	2.23	0.44	0.57	0.69	63.3	2.56	0.44	0.57	0.7	60.2	2.92	0.44	0.58	0.71	56.7	3.34	0.44	0.59	0.73
	2000	69.6	2.22	0.45	0.61	0.75	66.5	2.54	0.46	0.61	0.76	63.1	2.91	0.45	0.62	0.77	59.6	3.33	0.46	0.63	0.8

6 TON HIGH EFFICIENCY LCH074H4 (2ND STAGE)

Entering Wet Bulb Temperature	Total Air Volume	Outdoor Air Temperature Entering Outdoor Coil																			
		85°F					95°F					105°F					115°F				
		Total Cool Cap.	Comp. Motor Input	Sensible To Total Ratio (S/T)			Total Cool Cap.	Comp. Motor Input	Sensible To Total Ratio (S/T)			Total Cool Cap.	Comp. Motor Input	Sensible To Total Ratio (S/T)			Total Cool Cap.	Comp. Motor Input	Sensible To Total Ratio (S/T)		
				Dry Bulb					Dry Bulb					Dry Bulb					Dry Bulb		
cfm	kBtuh	kW	75°F	80°F	85°F	kBtuh	kW	75°F	80°F	85°F	kBtuh	kW	75°F	80°F	85°F	kBtuh	kW	75°F	80°F	85°F	
63°F	1920	68.6	4.12	0.73	0.88	1	64.9	4.65	0.75	0.9	1	60.9	5.25	0.77	0.93	1	56.6	5.94	0.79	0.96	1
	2400	72.2	4.16	0.79	0.96	1	68.1	4.68	0.81	0.99	1	63.9	5.28	0.83	1	1	60	5.97	0.86	1	1
	2880	75.2	4.18	0.85	1	1	71.6	4.72	0.87	1	1	67.6	5.32	0.9	1	1	63.4	6.01	0.94	1	1
67°F	1920	73	4.16	0.57	0.71	0.85	69	4.69	0.59	0.73	0.87	64.8	5.29	0.59	0.74	0.89	60.4	5.97	0.6	0.77	0.93
	2400	76.7	4.2	0.62	0.77	0.93	72.4	4.73	0.62	0.79	0.95	67.9	5.32	0.63	0.81	0.98	63	6	0.64	0.84	1
	2880	79.1	4.22	0.64	0.83	0.99	74.8	4.75	0.66	0.85	1	69.9	5.34	0.67	0.88	1	65	6.02	0.69	0.91	1
71°F	1920	77.6	4.21	0.44	0.56	0.69	73.5	4.74	0.43	0.57	0.7	69.1	5.34	0.43	0.58	0.72	64.2	6.02	0.43	0.59	0.74
	2400	81.1	4.24	0.45	0.6	0.75	76.8	4.77	0.45	0.61	0.77	72	5.37	0.45	0.62	0.79	67.1	6.05	0.44	0.64	0.81
	2880	83.7	4.27	0.47	0.64	0.8	79.3	4.8	0.46	0.65	0.83	74.2	5.4	0.48	0.66	0.85	69.2	6.07	0.48	0.68	0.89

DEHUMIDIFICATION SYSTEM RATINGS

6 TON HIGH EFFICIENCY LCH074H4 WITH DEHUMIDIFICATION OPERATING

Entering Wet Bulb Temperature	Total Air Volume	Outdoor Air Temperature Entering Outdoor Coil																			
		65°F					75°F					85°F					95°F				
		Total Cool Cap.	Comp. Motor Input	Sensible To Total Ratio (S/T) Dry Bulb			Total Cool Cap.	Comp. Motor Input	Sensible To Total Ratio (S/T) Dry Bulb			Total Cool Cap.	Comp. Motor Input	Sensible To Total Ratio (S/T) Dry Bulb			Total Cool Cap.	Comp. Motor Input	Sensible To Total Ratio (S/T) Dry Bulb		
				75°F	80°F	85°F			75°F	80°F	85°F			75°F	80°F	85°F			75°F	80°F	85°F
cfm	kBtuh	kW	75°F	80°F	85°F	kBtuh	kW	75°F	80°F	85°F	kBtuh	kW	75°F	80°F	85°F	kBtuh	kW	75°F	80°F	85°F	
63°F	1200	38.4	3.17	0.44	0.59	0.74	31.8	3.50	0.35	0.53	0.71	24.9	3.89	0.21	0.45	0.68	18.0	4.36	-0.04	0.29	0.61
	1600	41.9	3.22	0.49	0.68	0.86	34.4	3.54	0.42	0.63	0.86	26.4	3.91	0.28	0.58	0.86	18.4	4.36	0.03	0.45	0.86
	2000	44.1	3.26	0.55	0.77	0.97	35.5	3.56	0.49	0.76	1.00	28.1	3.94	0.35	0.64	1.00	18.1	4.36	0.10	0.64	1.00
67°F	1200	44.0	3.23	0.30	0.43	0.57	37.3	3.56	0.20	0.36	0.52	30.4	3.96	0.06	0.25	0.45	23.0	4.43	-0.18	0.09	0.33
	1600	47.7	3.29	0.33	0.49	0.65	39.8	3.61	0.23	0.43	0.61	32.0	3.99	0.08	0.32	0.56	23.8	4.44	-0.18	0.15	0.47
	2000	50.3	3.34	0.36	0.55	0.73	41.8	3.64	0.26	0.49	0.70	32.9	4.01	0.07	0.39	0.67	23.9	4.44	-0.18	0.23	0.62
71°F	1200	49.6	3.30	0.19	0.31	0.43	42.8	3.63	0.10	0.23	0.37	35.6	4.04	-0.05	0.12	0.28	28.4	4.51	-0.27	-0.06	0.15
	1600	53.7	3.37	0.19	0.34	0.48	45.9	3.69	0.09	0.26	0.43	37.8	4.07	-0.06	0.15	0.35	29.5	4.53	-0.31	-0.04	0.22
	2000	56.6	3.41	0.20	0.37	0.54	47.7	3.72	0.09	0.30	0.49	38.9	4.10	-0.08	0.17	0.42	29.6	4.53	-0.36	-0.02	0.30

BLOWER DATA

BLOWER TABLE INCLUDES RESISTANCE FOR BASE UNIT ONLY WITH DRY INDOOR COIL AND AIR FILTERS IN PLACE.

FOR ALL UNITS ADD:

1 - Any factory installed options air resistance (heat section, economizer, etc.).

2 - Any field installed accessories air resistance (duct resistance, diffuser, etc.).

See Page 40 for blower motors and drives and wet coil and options/accessory air resistance data.

DOWNFLOW

External Static Press. in. w.g.	Percentage of Total Motor Torque																										
	20%		30%		40%		50%		60%		70%		80%		90%		100%										
	Cfm	RPM	Cfm	RPM	Cfm	RPM	Cfm	RPM	Cfm	RPM	Cfm	RPM	Cfm	RPM	Cfm	RPM	Cfm	RPM									
0	785	38	407	969	68	468	1152	98	529	1301	140	581	1449	182	634	1571	236	683	1693	290	732	1799	352	770	1904	414	809
0.1	720	44	475	919	74	522	1117	104	569	1264	150	626	1411	195	684	1539	248	724	1667	301	765	1772	366	805	1877	431	844
0.2	645	50	550	851	83	593	1056	116	637	1218	161	680	1380	205	722	1509	259	762	1638	313	802	1744	380	840	1849	446	879
0.3	570	56	620	793	90	651	1016	124	681	1175	172	730	1334	220	779	1468	274	813	1601	328	846	1708	396	883	1815	464	920
0.4	505	60	678	731	97	712	956	135	746	1130	182	781	1303	229	815	1434	286	852	1564	342	889	1676	410	920	1787	477	951
0.5	432	65	740	663	105	775	895	145	810	1076	194	839	1257	243	867	1396	298	895	1534	353	923	1647	421	952	1759	489	981
0.6	---	---	---	---	---	---	855	152	852	1033	204	884	1211	256	917	1351	312	944	1490	369	971	1604	437	997	1718	505	1024
0.7	---	---	---	---	---	---	792	163	916	986	213	933	1180	264	949	1320	321	975	1460	379	1002	1575	447	1026	1690	515	1050
0.8	---	---	---	---	---	---	734	173	975	934	224	985	1134	275	995	1275	334	1021	1416	393	1046	1533	460	1067	1649	527	1088
0.9	---	---	---	---	---	---	674	183	1034	881	234	1037	1088	286	1039	1230	346	1064	1371	406	1088	1490	471	1106	1608	537	1123
1.0	---	---	---	---	---	---	613	193	1095	820	246	1094	1026	300	1093	1184	357	1104	1342	414	1115	1448	480	1140	1553	547	1165
1.1	---	---	---	---	---	---	---	---	---	---	---	---	980	309	1131	1139	367	1142	1297	425	1154	1404	488	1173	1511	551	1192
1.2	---	---	---	---	---	---	---	---	---	---	---	---	---	---	---	---	---	---	1253	436	1190	1355	495	1207	1456	554	1225

HORIZONTAL

External Static Press. in. w.g.	Percentage of Total Motor Torque																										
	20%		30%		40%		50%		60%		70%		80%		90%		100%										
	Cfm	RPM	Cfm	RPM	Cfm	RPM	Cfm	RPM	Cfm	RPM	Cfm	RPM	Cfm	RPM	Cfm	RPM	Cfm	RPM									
0	796	43	372	975	64	447	1155	85	524	1302	126	560	1448	168	597	1566	214	639	1684	260	680	1786	323	720	1888	386	761
0.1	709	50	461	909	75	512	1110	101	564	1254	143	613	1398	185	662	1523	231	695	1649	277	729	1754	344	769	1858	411	810
0.2	617	57	553	828	88	591	1040	118	629	1204	156	664	1368	194	698	1492	243	734	1616	291	771	1721	358	808	1826	424	845
0.3	503	64	662	747	97	668	992	131	676	1151	172	722	1310	212	768	1442	260	794	1574	308	820	1681	374	853	1787	440	887
0.4	419	69	747	671	107	746	924	146	747	1095	185	782	1266	225	818	1398	275	844	1530	325	870	1640	389	899	1749	454	927
0.5	323	75	843	589	117	832	857	159	821	1039	198	844	1221	237	867	1359	287	888	1496	337	909	1598	403	941	1701	470	973
0.6	---	---	---	---	---	---	817	165	871	990	208	900	1162	252	929	1296	306	954	1431	360	979	1546	421	995	1662	481	1010
0.7	---	---	---	---	---	---	747	176	957	933	219	966	1118	262	974	1264	314	987	1410	367	1000	1523	427	1016	1636	487	1032
0.8	---	---	---	---	---	---	700	181	1026	886	226	1022	1073	271	1018	1216	327	1035	1359	383	1051	1469	442	1066	1579	501	1081
0.9	---	---	---	---	---	---	643	187	1110	829	235	1091	1015	283	1073	1161	341	1087	1307	399	1101	1409	456	1118	1510	513	1136
1.0	---	---	---	---	---	---	592	190	1197	781	241	1154	970	291	1113	1114	352	1130	1258	413	1147	1355	467	1161	1452	520	1176
1.1	---	---	---	---	---	---	---	---	---	---	---	---	915	300	1162	1067	362	1171	1219	424	1180	1312	473	1192	1405	522	1204
1.2	---	---	---	---	---	---	---	---	---	---	---	---	---	---	---	---	---	---	1168	437	1223	1248	480	1235	1329	523	1246

BLOWER DATA

DIRECT DRIVE | 4 TON

BLOWER TABLE INCLUDES RESISTANCE FOR BASE UNIT ONLY WITH DRY INDOOR COIL AND AIR FILTERS IN PLACE.

FOR ALL UNITS ADD:

- 1 - Any factory installed options air resistance (heat section, economizer, etc.).
- 2 - Any field installed accessories air resistance (duct resistance, diffuser, etc.).

See Page 40 for blower motors and drives and wet coil and options/accessory air resistance data.

DOWNFLOW

External Static Press. in. w.g.	Percentage of Total Motor Torque																										
	20%			30%			40%			50%			60%			70%			80%			90%			100%		
	Cfm	Watts	RPM	Cfm	Watts	RPM	Cfm	Watts	RPM	Cfm	Watts	RPM	Cfm	Watts	RPM	Cfm	Watts	RPM	Cfm	Watts	RPM	Cfm	Watts	RPM	Cfm	Watts	RPM
0	1046	77	485	1257	134	565	1468	191	646	1639	271	715	1810	351	784	1960	445	837	2109	539	890	2251	674	947	2393	810	1004
0.1	992	85	543	1211	145	619	1430	205	695	1609	285	755	1788	365	814	1937	463	870	2086	561	925	2227	691	977	2367	822	1029
0.2	926	95	612	1166	154	669	1405	214	727	1580	299	793	1755	384	859	1909	482	909	2063	581	959	2200	708	1008	2336	835	1056
0.3	883	101	657	1125	164	715	1367	227	774	1551	311	831	1734	396	888	1891	495	934	2048	593	980	2181	719	1028	2314	844	1076
0.4	818	111	724	1074	175	772	1329	240	820	1515	327	875	1701	414	930	1859	515	975	2017	617	1021	2147	737	1064	2276	857	1107
0.5	752	121	791	1022	187	828	1291	253	865	1485	339	911	1679	425	957	1837	529	1003	1994	632	1049	2120	749	1090	2245	866	1131
0.6	---	---	---	---	---	---	1253	265	908	1450	354	952	1646	442	996	1809	544	1036	1972	646	1076	2094	760	1114	2215	873	1153
0.7	---	---	---	---	---	---	1202	282	965	1408	370	999	1613	458	1034	1777	560	1071	1941	662	1109	2063	771	1141	2185	879	1174
0.8	---	---	---	---	---	---	1164	294	1006	1372	383	1038	1580	473	1070	1745	574	1104	1910	676	1138	2025	781	1171	2139	886	1204
0.9	---	---	---	---	---	---	1126	306	1046	1337	396	1075	1548	487	1105	1714	587	1135	1880	687	1165	1987	788	1198	2094	889	1230
1.0	---	---	---	---	---	---	1081	320	1092	1298	410	1115	1515	500	1138	1675	599	1169	1834	699	1200	1941	794	1227	2048	889	1254
1.1	---	---	---	---	---	---	---	---	---	---	---	---	1476	514	1174	1632	609	1201	1788	704	1229	1896	795	1251	2003	886	1274
1.2	---	---	---	---	---	---	---	---	---	---	---	---	---	---	---	1728	702	1256	1835	790	1277	1942	878	1298	1942	878	1298

HORIZONTAL

External Static Press. in. w.g.	Percentage of Total Motor Torque																										
	20%			30%			40%			50%			60%			70%			80%			90%			100%		
	Cfm	Watts	RPM	Cfm	Watts	RPM	Cfm	Watts	RPM	Cfm	Watts	RPM	Cfm	Watts	RPM	Cfm	Watts	RPM	Cfm	Watts	RPM	Cfm	Watts	RPM	Cfm	Watts	RPM
0	1023	78	452	1234	131	536	1445	183	621	1611	251	688	1776	319	754	1910	400	800	2043	480	846	2192	613	904	2340	746	963
0.1	970	82	529	1192	137	596	1414	192	664	1586	261	722	1757	330	780	1902	427	837	2048	523	893	2189	640	942	2330	758	991
0.2	909	86	590	1146	144	647	1383	201	705	1553	275	764	1723	349	824	1876	444	873	2028	540	923	2170	659	970	2312	779	1018
0.3	829	95	675	1084	154	718	1339	213	761	1520	287	807	1701	361	853	1853	459	903	2005	557	953	2138	673	1001	2271	789	1049
0.4	772	104	734	1032	165	774	1293	226	814	1477	304	859	1661	382	904	1818	480	949	1975	579	993	2098	690	1039	2222	802	1084
0.5	688	118	818	967	178	841	1247	238	864	1439	317	902	1631	396	940	1787	498	986	1943	599	1032	2066	704	1069	2189	809	1106
0.6	---	---	---	---	---	---	1202	249	910	1400	330	944	1597	411	978	1758	512	1018	1920	613	1059	2035	715	1096	2150	817	1132
0.7	---	---	---	---	---	---	1146	265	967	1355	345	990	1565	426	1014	1727	527	1053	1889	629	1092	1997	726	1125	2105	822	1158
0.8	---	---	---	---	---	---	1085	280	1021	1302	362	1040	1520	443	1060	1685	544	1095	1849	646	1130	1950	737	1160	2051	828	1191
0.9	---	---	---	---	---	---	1029	292	1064	1255	376	1085	1481	460	1106	1643	560	1137	1805	660	1167	1898	745	1194	1991	830	1222
1.0	---	---	---	---	---	---	961	308	1114	1207	389	1126	1456	471	1137	1601	571	1173	1746	672	1209	1836	751	1230	1926	829	1251
1.1	---	---	---	---	---	---	---	---	---	---	---	---	1416	488	1185	1549	581	1213	1682	675	1241	1774	750	1258	1867	824	1276
1.2	---	---	---	---	---	---	---	---	---	---	---	---	---	---	---	1570	652	1268	1675	732	1286	1780	812	1305	1780	812	1305

DIRECT DRIVE | 5 TON

BLOWER DATA

BLOWER TABLE INCLUDES RESISTANCE FOR BASE UNIT ONLY WITH DRY INDOOR COIL AND AIR FILTERS IN PLACE.

FOR ALL UNITS ADD:

- 1 - Any factory installed options air resistance (heat section, economizer, etc.).
- 2 - Any field installed accessories air resistance (duct resistance, diffuser, etc.).

See Page 40 for blower motors and drives and wet coil and options/accessory air resistance data.

DOWNFLOW

External Static Press. in. w.g.	Percentage of Total Motor Torque																								
	20%		30%		40%		50%		60%		70%		80%		90%		100%								
	Cfm	RPM	Cfm	RPM	Cfm	RPM	Cfm	RPM	Cfm	RPM	Cfm	RPM	Cfm	RPM	Cfm	RPM	Cfm	RPM	Cfm	RPM					
0	1102	76	420	1324	143	510	601	1740	302	667	1934	393	734	2096	519	797	2258	645	860	2396	791	910	2534	938	959
0.1	1038	85	484	1284	153	559	633	1722	315	698	1914	410	763	2078	535	823	2242	660	882	2378	810	934	2514	960	986
0.2	975	94	546	1235	165	611	677	1692	332	737	1888	429	798	2057	553	851	2225	677	905	2363	825	954	2501	973	1003
0.3	911	104	603	1192	175	654	706	1672	343	763	1871	441	820	2040	566	874	2208	692	928	2348	839	974	2488	987	1020
0.4	847	114	657	1143	187	702	747	1642	359	800	1845	458	852	2015	585	904	2185	712	956	2327	858	1000	2469	1005	1044
0.5	784	124	708	1095	198	747	785	1613	374	835	1819	475	884	1994	600	931	2168	726	977	2309	874	1022	2450	1022	1066
0.6	---	---	---	---	---	---	822	1583	388	868	1793	490	915	1969	617	959	2145	743	1004	2288	890	1046	2431	1037	1087
0.7	---	---	---	---	---	---	856	1553	401	900	1767	505	944	1945	633	987	2122	760	1029	2267	906	1068	2411	1051	1108
0.8	---	---	---	---	---	---	899	1518	416	936	1741	519	973	1920	647	1013	2099	776	1054	2246	920	1090	2392	1064	1127
0.9	---	---	---	---	---	---	937	1478	432	974	1706	537	1010	1891	663	1043	2076	790	1077	2221	934	1113	2366	1078	1150
1.0	---	---	---	---	---	---	980	1437	446	1008	1680	549	1036	1867	676	1067	2053	803	1098	2200	945	1132	2347	1087	1166
1.1	---	---	---	---	---	---	---	---	---	---	1649	562	1066	1834	691	1097	2019	821	1129	2164	961	1162	2308	1100	1194
1.2	---	---	---	---	---	---	---	---	---	---	---	---	---	---	---	---	1984	836	1157	2133	971	1184	2282	1106	1211

HORIZONTAL

External Static Press. in. w.g.	Percentage of Total Motor Torque																								
	20%		30%		40%		50%		60%		70%		80%		90%		100%								
	Cfm	RPM	Cfm	RPM	Cfm	RPM	Cfm	RPM	Cfm	RPM	Cfm	RPM	Cfm	RPM	Cfm	RPM	Cfm	RPM	Cfm	RPM	Cfm	RPM	Cfm	RPM	Cfm
0	1129	85	418	1343	146	512	606	1740	306	679	1923	405	752	2084	530	812	2245	655	872	2377	807	927	2508	959	982
0.1	1063	88	464	1295	154	550	635	1715	318	705	1903	417	776	2070	546	835	2237	675	895	2368	823	948	2498	972	1002
0.2	984	95	534	1234	166	607	680	1681	335	743	1878	432	807	2046	562	863	2214	691	920	2347	842	971	2479	993	1023
0.3	917	103	606	1178	179	665	724	1645	351	780	1852	447	836	2018	580	894	2183	712	952	2321	862	997	2459	1012	1043
0.4	862	112	681	1128	192	725	768	1604	370	823	1814	468	878	1987	598	927	2160	728	975	2298	881	1021	2435	1034	1067
0.5	818	124	760	1091	204	779	798	1576	383	851	1788	482	905	1963	612	951	2137	742	997	2274	898	1044	2410	1055	1090
0.6	---	---	---	---	---	---	842	1541	398	886	1762	495	931	1934	628	979	2106	761	1026	2244	919	1071	2381	1076	1115
0.7	---	---	---	---	---	---	885	1499	415	926	1724	513	967	1900	646	1010	2075	779	1054	2219	934	1093	2362	1089	1131
0.8	---	---	---	---	---	---	914	1466	429	957	1686	531	1001	1865	663	1040	2044	796	1080	2188	951	1117	2332	1106	1154
0.9	---	---	---	---	---	---	957	1424	446	995	1647	547	1032	1830	679	1069	2013	812	1105	2154	968	1143	2294	1124	1181
1.0	---	---	---	---	---	---	1000	1382	461	1030	1609	563	1061	1796	695	1095	1983	826	1129	2124	980	1164	2264	1134	1200
1.1	---	---	---	---	---	---	---	---	---	---	1570	577	1087	1753	712	1124	1936	847	1162	2086	994	1189	2235	1141	1216
1.2	---	---	---	---	---	---	---	---	---	---	---	---	---	---	---	---	1905	859	1182	2041	1003	1213	2176	1146	1244

BLOWER DATA

BELT DRIVE | 3 TON | DOWNFLOW

BLOWER TABLE INCLUDES RESISTANCE FOR BASE UNIT ONLY WITH DRY INDOOR COIL AND AIR FILTERS IN PLACE.

FOR ALL UNITS ADD:

1 - Any factory installed options air resistance (heat section, economizer, etc.).

2 - Any field installed accessories air resistance (duct resistance, diffuser, etc.).

See Page 40 for blower motors and drives and wet coil and options/accessory air resistance data.

Air Volume (cfm)	External Static (in.w.g.)																			
	0.10		0.20		0.30		0.40		0.50		0.60		0.70		0.80		0.9		1.0	
	RPM	BHP	RPM	BHP	RPM	BHP	RPM	BHP	RPM	BHP	RPM	BHP	RPM	BHP	RPM	BHP	RPM	BHP	RPM	BHP
700	447	0.09	517	0.12	589	0.15	663	0.17	739	0.19	815	0.2	883	0.23	938	0.25	988	0.27	1039	0.29
800	465	0.1	534	0.14	605	0.17	678	0.19	753	0.21	825	0.23	890	0.25	946	0.27	996	0.3	1047	0.32
900	486	0.12	554	0.16	623	0.2	695	0.22	767	0.23	836	0.25	897	0.28	953	0.3	1004	0.33	1055	0.35
1000	508	0.15	576	0.19	643	0.22	713	0.24	783	0.26	848	0.28	907	0.3	961	0.33	1011	0.36	1062	0.38
1100	533	0.18	599	0.22	665	0.25	733	0.27	800	0.28	863	0.31	919	0.34	971	0.36	1020	0.39	1070	0.41
1200	560	0.21	625	0.25	689	0.28	755	0.3	820	0.32	879	0.34	932	0.37	983	0.4	1031	0.43	1079	0.45
1300	591	0.24	654	0.28	716	0.31	779	0.33	841	0.35	897	0.38	948	0.41	996	0.44	1044	0.47	1091	0.49
1400	631	0.26	690	0.3	748	0.34	807	0.36	864	0.39	916	0.42	964	0.46	1011	0.49	1058	0.51	1105	0.54

Air Volume (cfm)	External Static (in.w.g.)																			
	1.1		1.2		1.3		1.4		1.5		1.6		1.7		1.8		1.9		2.0	
	RPM	BHP	RPM	BHP	RPM	BHP	RPM	BHP	RPM	BHP	RPM	BHP	RPM	BHP	RPM	BHP	RPM	BHP	RPM	BHP
700	1088	0.31	---	---	---	---	---	---	---	---	---	---	---	---	---	---	---	---	---	---
800	1098	0.34	1144	0.36	1185	0.39	1224	0.42	---	---	---	---	---	---	---	---	---	---	---	---
900	1106	0.37	1152	0.4	1193	0.43	1232	0.46	1269	0.49	1305	0.52	1340	0.55	1376	0.59	---	---	---	---
1000	1111	0.41	1157	0.43	1199	0.47	1238	0.5	1276	0.53	1311	0.56	1347	0.6	1382	0.63	1417	0.67	1452	0.7
1100	1118	0.44	1163	0.47	1206	0.51	1245	0.54	1282	0.58	1318	0.61	1353	0.65	1388	0.68	1423	0.72	1458	0.75
1200	1127	0.48	1171	0.52	1213	0.55	1252	0.59	1289	0.62	1324	0.66	1358	0.7	1393	0.73	1428	0.77	1463	0.81
1300	1137	0.53	1181	0.56	1221	0.6	1259	0.64	1296	0.68	1330	0.71	1364	0.75	1398	0.78	1432	0.82	1467	0.86
1400	1150	0.57	1191	0.61	1231	0.65	1268	0.69	1303	0.73	1337	0.77	1371	0.8	1404	0.84	1437	0.88	1473	0.91

BLOWER DATA

BELT DRIVE | 3 TON | HORIZONTAL

BLOWER TABLE INCLUDES RESISTANCE FOR BASE UNIT ONLY WITH DRY INDOOR COIL AND AIR FILTERS IN PLACE.

FOR ALL UNITS ADD:

- 1 - Any factory installed options air resistance (heat section, economizer, etc.).
- 2 - Any field installed accessories air resistance (duct resistance, diffuser, etc.).

See Page 40 for blower motors and drives and wet coil and options/accessory air resistance data.

Air Volume (cfm)	External Static (in.w.g.)																			
	0.10		0.20		0.30		0.40		0.50		0.60		0.70		0.80		0.9		1.0	
	RPM	BHP	RPM	BHP	RPM	BHP	RPM	BHP	RPM	BHP	RPM	BHP	RPM	BHP	RPM	BHP	RPM	BHP	RPM	BHP
700	445	0.08	516	0.11	591	0.13	670	0.15	753	0.16	820	0.19	870	0.22	918	0.24	969	0.27	1021	0.29
800	463	0.09	534	0.12	608	0.14	685	0.16	766	0.18	830	0.21	878	0.24	926	0.27	977	0.29	1030	0.32
900	485	0.11	554	0.14	627	0.16	703	0.18	780	0.21	841	0.23	888	0.27	935	0.3	986	0.32	1039	0.35
1000	509	0.13	578	0.16	649	0.19	722	0.21	796	0.23	854	0.26	900	0.29	947	0.33	997	0.35	1048	0.38
1100	537	0.16	605	0.19	674	0.21	744	0.24	813	0.26	868	0.29	913	0.33	959	0.36	1008	0.39	1059	0.41
1200	567	0.19	633	0.22	700	0.24	768	0.27	833	0.3	884	0.33	928	0.37	974	0.4	1022	0.43	1071	0.45
1300	599	0.22	664	0.25	729	0.28	793	0.3	853	0.33	902	0.37	945	0.41	990	0.44	1037	0.47	1085	0.5
1400	634	0.26	697	0.29	758	0.31	819	0.34	875	0.38	921	0.42	964	0.46	1008	0.49	1054	0.52	1100	0.54

Air Volume (cfm)	External Static (in.w.g.)																			
	1.1		1.2		1.3		1.4		1.5		1.6		1.7		1.8		1.9		2.0	
	RPM	BHP	RPM	BHP	RPM	BHP	RPM	BHP	RPM	BHP	RPM	BHP	RPM	BHP	RPM	BHP	RPM	BHP	RPM	BHP
700	1071	0.32	---	---	---	---	---	---	---	---	---	---	---	---	---	---	---	---	---	---
800	1082	0.34	1128	0.37	1169	0.4	1205	0.42	---	---	---	---	---	---	---	---	---	---	---	---
900	1090	0.37	1137	0.4	1177	0.43	1214	0.46	1248	0.49	1280	0.51	1310	0.54	1340	0.57	---	---	---	---
1000	1098	0.41	1143	0.44	1184	0.47	1221	0.5	1255	0.53	1287	0.56	1318	0.59	1347	0.61	1377	0.64	1406	0.67
1100	1107	0.44	1150	0.47	1191	0.51	1228	0.54	1263	0.57	1295	0.6	1325	0.63	1355	0.66	1384	0.69	1413	0.72
1200	1117	0.48	1160	0.52	1200	0.55	1237	0.59	1271	0.62	1303	0.66	1334	0.69	1363	0.72	1392	0.75	1420	0.78
1300	1130	0.53	1171	0.57	1210	0.6	1246	0.64	1280	0.68	1312	0.71	1342	0.74	1372	0.78	1400	0.81	1429	0.84
1400	1144	0.58	1183	0.62	1221	0.66	1256	0.7	1290	0.73	1321	0.77	1352	0.8	1381	0.84	1410	0.87	1439	0.9

BLOWER DATA

BELT DRIVE | 4 TON | DOWNFLOW

BLOWER TABLE INCLUDES RESISTANCE FOR BASE UNIT ONLY WITH DRY INDOOR COIL AND AIR FILTERS IN PLACE.

FOR ALL UNITS ADD:

1 - Any factory installed options air resistance (heat section, economizer, etc.).

2 - Any field installed accessories air resistance (duct resistance, diffuser, etc.).

See Page 40 for blower motors and drives and wet coil and options/accessory air resistance data.

Air Volume (cfm)	External Static (in.w.g.)																			
	0.10		0.20		0.30		0.40		0.50		0.60		0.70		0.80		0.9		1.0	
	RPM	BHP	RPM	BHP	RPM	BHP	RPM	BHP	RPM	BHP	RPM	BHP	RPM	BHP	RPM	BHP	RPM	BHP	RPM	BHP
900	496	0.13	568	0.16	640	0.18	711	0.2	779	0.22	844	0.25	905	0.28	960	0.3	1010	0.33	1061	0.35
1000	521	0.15	592	0.18	662	0.2	731	0.23	796	0.25	858	0.28	916	0.31	969	0.34	1019	0.36	1069	0.38
1100	548	0.18	618	0.21	686	0.23	752	0.25	814	0.28	873	0.31	929	0.34	980	0.37	1029	0.39	1078	0.42
1200	577	0.21	646	0.24	712	0.26	775	0.29	834	0.31	890	0.35	943	0.38	993	0.41	1041	0.43	1089	0.46
1300	611	0.24	677	0.27	740	0.3	800	0.32	856	0.35	909	0.39	959	0.42	1007	0.45	1055	0.47	1102	0.5
1400	654	0.26	713	0.29	771	0.33	826	0.36	878	0.39	928	0.43	976	0.47	1023	0.49	1070	0.52	1117	0.55
1500	698	0.28	751	0.32	802	0.36	852	0.4	901	0.44	948	0.48	995	0.51	1041	0.54	1088	0.57	1133	0.6
1600	738	0.32	785	0.36	831	0.41	878	0.45	923	0.49	969	0.53	1014	0.57	1061	0.59	1107	0.62	1151	0.66
1700	773	0.36	816	0.41	859	0.46	903	0.51	947	0.55	991	0.58	1036	0.62	1082	0.65	1128	0.68	1169	0.72
1800	803	0.42	844	0.47	886	0.52	929	0.57	972	0.61	1016	0.64	1060	0.68	1106	0.71	1150	0.74	1189	0.79
1900	831	0.48	872	0.54	915	0.59	957	0.63	1000	0.67	1043	0.71	1087	0.74	1131	0.78	1173	0.81	1208	0.86

Air Volume (cfm)	External Static (in.w.g.)																			
	1.1		1.2		1.3		1.4		1.5		1.6		1.7		1.8		1.9		2.0	
	RPM	BHP	RPM	BHP	RPM	BHP	RPM	BHP	RPM	BHP	RPM	BHP	RPM	BHP	RPM	BHP	RPM	BHP	RPM	BHP
900	1112	0.38	1157	0.4	1198	0.43	1236	0.46	1273	0.49	1309	0.52	1344	0.56	1380	0.59	---	---	---	---
1000	1119	0.41	1164	0.44	1206	0.47	1244	0.5	1281	0.54	1317	0.57	1352	0.6	1387	0.64	1422	0.67	1458	0.71
1100	1126	0.45	1171	0.48	1213	0.51	1252	0.55	1288	0.58	1324	0.62	1359	0.65	1394	0.69	1429	0.72	1464	0.76
1200	1136	0.49	1180	0.52	1221	0.56	1259	0.6	1296	0.63	1331	0.67	1365	0.7	1400	0.74	1435	0.78	1471	0.81
1300	1148	0.53	1190	0.57	1230	0.61	1268	0.65	1304	0.68	1338	0.72	1372	0.76	1406	0.79	1440	0.83	1476	0.87
1400	1161	0.58	1202	0.62	1240	0.66	1277	0.7	1312	0.74	1346	0.78	1379	0.81	1412	0.85	1446	0.89	1482	0.92
1500	1175	0.64	1214	0.68	1252	0.72	1287	0.76	1321	0.8	1355	0.83	1387	0.87	1420	0.91	1454	0.95	1490	0.99
1600	1190	0.7	1228	0.74	1264	0.78	1298	0.82	1332	0.86	1364	0.9	1397	0.93	1430	0.97	1464	1.01	1499	1.06
1700	1206	0.76	1242	0.8	1277	0.84	1310	0.88	1343	0.92	1375	0.96	1407	1	1440	1.04	1475	1.09	1510	1.13
1800	1223	0.83	1257	0.87	1291	0.91	1324	0.95	1356	0.99	1388	1.03	1420	1.08	1453	1.12	1487	1.16	1523	1.21
1900	1240	0.91	1273	0.95	1306	0.99	1338	1.03	1369	1.07	1401	1.12	1433	1.16	1467	1.2	1501	1.25	1537	1.29

BLOWER DATA

BELT DRIVE | 4 TON | HORIZONTAL

BLOWER TABLE INCLUDES RESISTANCE FOR BASE UNIT ONLY WITH DRY INDOOR COIL AND AIR FILTERS IN PLACE.

FOR ALL UNITS ADD:

1 - Any factory installed options air resistance (heat section, economizer, etc.).

2 - Any field installed accessories air resistance (duct resistance, diffuser, etc.).

See Page 40 for blower motors and drives and wet coil and options/accessory air resistance data.

Air Volume (cfm)	External Static (in.w.g.)																			
	0.10		0.20		0.30		0.40		0.50		0.60		0.70		0.80		0.9		1.0	
	RPM	BHP	RPM	BHP	RPM	BHP	RPM	BHP	RPM	BHP	RPM	BHP	RPM	BHP	RPM	BHP	RPM	BHP	RPM	BHP
900	493	0.12	564	0.14	637	0.17	712	0.19	788	0.21	847	0.24	894	0.27	942	0.3	993	0.33	1046	0.35
1000	520	0.14	589	0.17	660	0.19	733	0.21	805	0.24	861	0.27	907	0.3	954	0.33	1004	0.36	1056	0.38
1100	549	0.16	617	0.19	686	0.22	756	0.24	823	0.27	876	0.3	921	0.33	968	0.37	1017	0.39	1067	0.42
1200	582	0.19	648	0.22	714	0.25	781	0.27	843	0.3	893	0.34	938	0.37	984	0.41	1032	0.43	1081	0.46
1300	624	0.22	686	0.25	747	0.28	808	0.31	865	0.34	912	0.38	956	0.42	1001	0.45	1048	0.48	1096	0.5
1400	670	0.24	726	0.27	782	0.31	837	0.35	887	0.39	932	0.43	975	0.47	1020	0.5	1066	0.52	1112	0.55
1500	714	0.26	765	0.31	814	0.35	863	0.39	910	0.44	953	0.48	996	0.52	1041	0.55	1086	0.58	1130	0.61
1600	752	0.3	798	0.35	844	0.4	889	0.45	933	0.49	975	0.53	1018	0.57	1062	0.6	1107	0.63	1149	0.67
1700	785	0.35	827	0.4	871	0.46	914	0.51	957	0.55	999	0.59	1042	0.63	1085	0.66	1129	0.69	1169	0.73
1800	813	0.42	855	0.47	898	0.52	940	0.57	983	0.62	1025	0.66	1067	0.69	1110	0.72	1152	0.76	1190	0.8
1900	841	0.49	883	0.54	926	0.6	969	0.65	1011	0.69	1052	0.72	1094	0.76	1136	0.79	1176	0.83	1212	0.89

Air Volume (cfm)	External Static (in.w.g.)																			
	1.1		1.2		1.3		1.4		1.5		1.6		1.7		1.8		1.9		2.0	
	RPM	BHP	RPM	BHP	RPM	BHP	RPM	BHP	RPM	BHP	RPM	BHP	RPM	BHP	RPM	BHP	RPM	BHP	RPM	BHP
900	1097	0.38	1142	0.41	1182	0.43	1218	0.46	1252	0.49	1284	0.52	1314	0.55	1344	0.57	---	---	---	---
1000	1105	0.41	1149	0.44	1190	0.47	1226	0.5	1260	0.53	1292	0.56	1322	0.59	1352	0.62	1381	0.65	1410	0.68
1100	1115	0.45	1158	0.48	1198	0.51	1235	0.55	1269	0.58	1301	0.61	1331	0.64	1360	0.67	1389	0.7	1418	0.73
1200	1126	0.49	1168	0.53	1208	0.56	1244	0.6	1278	0.63	1309	0.66	1340	0.69	1369	0.72	1398	0.75	1426	0.78
1300	1140	0.54	1180	0.57	1218	0.61	1254	0.65	1287	0.68	1319	0.72	1349	0.75	1378	0.78	1407	0.81	1436	0.84
1400	1154	0.59	1193	0.63	1230	0.67	1265	0.7	1298	0.74	1330	0.78	1360	0.81	1389	0.85	1418	0.88	1447	0.91
1500	1170	0.65	1208	0.69	1244	0.73	1278	0.77	1310	0.8	1341	0.84	1371	0.88	1401	0.91	1430	0.95	1459	0.98
1600	1187	0.71	1223	0.75	1258	0.79	1291	0.83	1323	0.87	1354	0.91	1384	0.95	1414	0.99	1443	1.02	1474	1.06
1700	1204	0.78	1240	0.82	1274	0.86	1306	0.9	1338	0.95	1369	0.99	1399	1.03	1429	1.06	1459	1.1	1490	1.14
1800	1223	0.85	1258	0.9	1291	0.94	1323	0.99	1354	1.03	1385	1.07	1415	1.11	1445	1.15	1476	1.19	1507	1.23
1900	1243	0.94	1277	0.99	1309	1.03	1341	1.08	1372	1.12	1402	1.16	1433	1.2	1464	1.24	1495	1.28	1527	1.32

BLOWER DATA

BELT DRIVE | 5 TON | DOWNFLOW

BLOWER TABLE INCLUDES RESISTANCE FOR BASE UNIT ONLY WITH DRY INDOOR COIL AND AIR FILTERS IN PLACE.

FOR ALL UNITS ADD:

- 1 - Any factory installed options air resistance (heat section, economizer, etc.).
- 2 - Any field installed accessories air resistance (duct resistance, diffuser, etc.).

See Page 40 for blower motors and drives and wet coil and options/accessory air resistance data.

Air Volume (cfm)	External Static (in.w.g.)																			
	0.10		0.20		0.30		0.40		0.50		0.60		0.70		0.80		0.9		1.0	
	RPM	BHP	RPM	BHP	RPM	BHP	RPM	BHP	RPM	BHP	RPM	BHP	RPM	BHP	RPM	BHP	RPM	BHP	RPM	BHP
1100	512	0.15	571	0.19	630	0.23	690	0.26	770	0.26	854	0.26	922	0.27	970	0.30	1006	0.35	1045	0.39
1200	535	0.18	593	0.22	651	0.26	710	0.29	788	0.30	868	0.30	933	0.31	978	0.34	1013	0.38	1053	0.42
1300	559	0.22	616	0.26	674	0.29	732	0.32	807	0.34	883	0.34	944	0.35	987	0.38	1022	0.42	1062	0.46
1400	584	0.26	641	0.29	698	0.33	755	0.36	827	0.37	899	0.38	956	0.40	997	0.43	1033	0.47	1072	0.51
1500	615	0.29	671	0.33	726	0.36	782	0.39	850	0.41	917	0.42	970	0.44	1009	0.47	1045	0.52	1085	0.56
1600	665	0.30	716	0.34	768	0.38	819	0.41	879	0.44	937	0.46	985	0.49	1022	0.52	1059	0.57	1098	0.61
1700	723	0.31	768	0.35	814	0.39	860	0.43	910	0.47	959	0.50	1001	0.54	1037	0.58	1074	0.62	1113	0.66
1800	779	0.32	818	0.37	857	0.41	897	0.46	939	0.50	980	0.55	1018	0.59	1054	0.64	1091	0.68	1129	0.72
1900	826	0.36	859	0.41	894	0.45	928	0.50	964	0.56	1000	0.61	1036	0.66	1072	0.70	1109	0.75	1146	0.79
2000	857	0.42	889	0.47	920	0.52	952	0.57	986	0.62	1020	0.68	1055	0.73	1091	0.77	1128	0.82	1164	0.86
2100	878	0.49	909	0.54	940	0.59	973	0.64	1006	0.70	1041	0.75	1076	0.80	1112	0.85	1148	0.89	1185	0.93
2200	897	0.55	929	0.61	961	0.66	994	0.72	1028	0.78	1063	0.83	1099	0.89	1134	0.93	1170	0.97	1206	1.01
2300	918	0.62	950	0.68	983	0.74	1017	0.80	1052	0.86	1087	0.92	1122	0.97	1157	1.02	1193	1.06	1228	1.09
2400	941	0.70	974	0.77	1008	0.83	1042	0.90	1077	0.96	1111	1.01	1146	1.06	1181	1.11	1216	1.15	1250	1.19

Air Volume (cfm)	External Static (in.w.g.)																			
	1.1		1.2		1.3		1.4		1.5		1.6		1.7		1.8		1.9		2.0	
	RPM	BHP	RPM	BHP	RPM	BHP	RPM	BHP	RPM	BHP	RPM	BHP	RPM	BHP	RPM	BHP	RPM	BHP	RPM	BHP
1100	1089	0.43	1134	0.46	---	---	---	---	---	---	---	---	---	---	---	---	---	---	---	---
1200	1095	0.46	1139	0.50	1186	0.53	1230	0.57	1266	0.60	---	---	---	---	---	---	---	---	---	---
1300	1104	0.50	1146	0.54	1192	0.57	1234	0.60	1269	0.64	1301	0.68	1334	0.71	1367	0.75	---	---	---	---
1400	1114	0.55	1155	0.58	1199	0.61	1240	0.65	1275	0.68	1305	0.72	1338	0.76	1372	0.80	1406	0.83	1440	0.87
1500	1125	0.60	1165	0.63	1208	0.66	1248	0.69	1281	0.73	1311	0.77	1344	0.81	1378	0.85	1412	0.89	1446	0.92
1600	1138	0.65	1177	0.68	1218	0.71	1257	0.75	1290	0.79	1319	0.83	1352	0.87	1385	0.91	1418	0.95	1452	0.98
1700	1152	0.70	1190	0.74	1231	0.77	1268	0.80	1299	0.84	1328	0.89	1360	0.93	1393	0.97	1426	1.01	1459	1.05
1800	1167	0.76	1205	0.80	1244	0.83	1280	0.87	1310	0.91	1338	0.95	1370	0.99	1402	1.04	1434	1.08	1466	1.11
1900	1183	0.82	1221	0.86	1260	0.90	1294	0.94	1323	0.98	1349	1.02	1380	1.07	1412	1.11	1443	1.15	1475	1.19
2000	1201	0.89	1239	0.93	1276	0.97	1310	1.01	1336	1.06	1362	1.10	1392	1.15	1423	1.19	1454	1.23	1485	1.27
2100	1221	0.97	1258	1.01	1294	1.05	1325	1.09	1351	1.14	1376	1.19	1406	1.23	1436	1.27	1466	1.31	1497	1.35
2200	1242	1.05	1277	1.09	1311	1.14	1341	1.18	1365	1.23	1390	1.28	1420	1.32	1450	1.36	1480	1.41	1510	1.45
2300	1262	1.14	1295	1.19	1327	1.24	1355	1.29	1380	1.33	1406	1.37	1435	1.42	1465	1.46	1494	1.50	1524	1.54
2400	1282	1.24	1313	1.30	1343	1.36	1371	1.40	1396	1.44	1423	1.48	1452	1.52	1481	1.56	1510	1.60	1540	1.64

BLOWER DATA

BELT DRIVE | 5 TON | HORIZONTAL

BLOWER TABLE INCLUDES RESISTANCE FOR BASE UNIT ONLY WITH DRY INDOOR COIL AND AIR FILTERS IN PLACE.

FOR ALL UNITS ADD:

- 1 - Any factory installed options air resistance (heat section, economizer, etc.).
- 2 - Any field installed accessories air resistance (duct resistance, diffuser, etc.).

See Page 40 for blower motors and drives and wet coil and options/accessory air resistance data.

Air Volume (cfm)	External Static (in.w.g.)																			
	0.10		0.20		0.30		0.40		0.50		0.60		0.70		0.80		0.9		1.0	
	RPM	BHP	RPM	BHP	RPM	BHP	RPM	BHP	RPM	BHP	RPM	BHP	RPM	BHP	RPM	BHP	RPM	BHP	RPM	BHP
1100	509	0.15	562	0.18	624	0.20	691	0.22	771	0.24	852	0.25	919	0.28	970	0.31	1010	0.35	1049	0.38
1200	535	0.18	589	0.21	650	0.23	715	0.25	792	0.27	869	0.29	932	0.32	980	0.35	1019	0.38	1058	0.42
1300	564	0.21	618	0.24	678	0.27	741	0.29	815	0.31	887	0.33	946	0.36	991	0.39	1030	0.43	1068	0.47
1400	604	0.24	657	0.27	715	0.30	775	0.33	842	0.35	908	0.37	962	0.40	1004	0.43	1042	0.47	1080	0.51
1500	656	0.26	706	0.30	760	0.33	814	0.36	874	0.39	931	0.41	979	0.45	1019	0.48	1056	0.53	1094	0.57
1600	712	0.29	758	0.32	807	0.36	855	0.39	906	0.43	955	0.46	997	0.50	1035	0.54	1071	0.58	1109	0.62
1700	766	0.32	808	0.36	850	0.40	892	0.44	936	0.47	978	0.51	1016	0.56	1052	0.60	1088	0.64	1126	0.68
1800	814	0.36	851	0.40	888	0.44	925	0.49	963	0.53	1000	0.57	1035	0.62	1071	0.66	1107	0.70	1143	0.74
1900	853	0.41	886	0.46	919	0.50	952	0.55	986	0.60	1021	0.64	1056	0.69	1091	0.73	1126	0.77	1163	0.81
2000	883	0.48	913	0.53	944	0.57	976	0.62	1009	0.67	1043	0.71	1078	0.76	1112	0.80	1148	0.84	1183	0.88
2100	906	0.56	936	0.60	967	0.65	999	0.70	1033	0.75	1067	0.79	1101	0.84	1135	0.88	1170	0.92	1206	0.96
2200	930	0.64	960	0.68	991	0.73	1024	0.78	1058	0.83	1092	0.88	1126	0.92	1160	0.96	1195	1.00	1230	1.04
2300	954	0.72	985	0.77	1017	0.82	1051	0.87	1085	0.92	1119	0.96	1152	1.00	1186	1.04	1220	1.08	1254	1.13
2400	981	0.81	1013	0.86	1046	0.91	1079	0.96	1113	1.00	1146	1.05	1180	1.09	1213	1.13	1245	1.18	1278	1.22

Air Volume (cfm)	External Static (in.w.g.)																			
	1.1		1.2		1.3		1.4		1.5		1.6		1.7		1.8		1.9		2.0	
	RPM	BHP	RPM	BHP	RPM	BHP	RPM	BHP	RPM	BHP	RPM	BHP	RPM	BHP	RPM	BHP	RPM	BHP	RPM	BHP
1100	1091	0.42	1134	0.45	1176	0.48	1218	0.51	1258	0.54	1297	0.57	1335	0.59	---	---	---	---	---	---
1200	1099	0.46	1141	0.49	1182	0.52	1223	0.55	1263	0.58	1302	0.61	1339	0.64	1376	0.67	1410	0.70	1444	0.72
1300	1108	0.50	1149	0.53	1190	0.56	1230	0.59	1270	0.63	1308	0.66	1345	0.70	1381	0.73	1415	0.75	1449	0.78
1400	1120	0.55	1160	0.58	1200	0.61	1240	0.65	1278	0.68	1315	0.72	1352	0.75	1387	0.78	1421	0.81	1454	0.84
1500	1133	0.60	1172	0.63	1212	0.67	1250	0.70	1288	0.74	1324	0.77	1360	0.81	1394	0.84	1428	0.87	1460	0.90
1600	1147	0.66	1186	0.69	1225	0.72	1263	0.76	1299	0.80	1334	0.83	1369	0.87	1402	0.90	1435	0.94	1467	0.96
1700	1164	0.72	1202	0.75	1240	0.78	1276	0.82	1311	0.86	1345	0.90	1379	0.93	1411	0.97	1443	1.00	1475	1.03
1800	1181	0.78	1219	0.81	1256	0.85	1291	0.89	1324	0.93	1357	0.97	1390	1.00	1421	1.04	1453	1.07	1483	1.10
1900	1200	0.85	1237	0.88	1273	0.92	1306	0.96	1339	1.00	1371	1.04	1402	1.08	1433	1.11	1463	1.15	1493	1.18
2000	1220	0.92	1257	0.96	1291	1.00	1323	1.04	1354	1.08	1385	1.12	1416	1.16	1446	1.20	1476	1.23	1505	1.26
2100	1242	1.00	1277	1.04	1310	1.08	1340	1.13	1371	1.17	1401	1.21	1431	1.25	1460	1.29	1489	1.32	1519	1.36
2200	1265	1.08	1299	1.13	1330	1.18	1359	1.23	1388	1.27	1418	1.31	1447	1.35	1476	1.39	1504	1.42	1533	1.45
2300	1288	1.17	1320	1.23	1350	1.28	1378	1.34	1406	1.38	1435	1.42	1464	1.46	1492	1.50	1521	1.53	1549	1.56
2400	1311	1.28	1341	1.33	1370	1.40	1397	1.45	1425	1.50	1454	1.54	1482	1.57	1510	1.61	1538	1.64	1567	1.67

BLOWER DATA

BELT DRIVE | 6 TON | DOWNFLOW

BLOWER TABLE INCLUDES RESISTANCE FOR BASE UNIT ONLY WITH DRY INDOOR COIL AND AIR FILTERS IN PLACE.

FOR ALL UNITS ADD:

- 1 - Any factory installed options air resistance (heat section, economizer, etc.).
- 2 - Any field installed accessories air resistance (duct resistance, diffuser, etc.).

See Page 40 for blower motors and drives and wet coil and options/accessory air resistance data.

Air Volume (cfm)	External Static (in.w.g.)																			
	0.10		0.20		0.30		0.40		0.50		0.60		0.70		0.80		0.9		1.0	
	RPM	BHP	RPM	BHP	RPM	BHP	RPM	BHP	RPM	BHP	RPM	BHP	RPM	BHP	RPM	BHP	RPM	BHP	RPM	BHP
1900	480	0.38	512	0.44	545	0.51	579	0.57	614	0.63	648	0.7	683	0.76	719	0.83	752	0.89	781	0.95
2000	493	0.43	525	0.49	558	0.56	592	0.62	626	0.68	659	0.75	693	0.81	728	0.88	759	0.94	788	1
2100	507	0.48	539	0.54	572	0.61	605	0.67	639	0.74	671	0.8	704	0.86	737	0.93	768	0.99	795	1.04
2200	522	0.53	554	0.6	587	0.66	619	0.73	652	0.79	684	0.86	716	0.92	747	0.98	777	1.04	803	1.1
2300	537	0.59	569	0.65	602	0.72	634	0.79	666	0.85	697	0.91	728	0.98	758	1.04	786	1.1	812	1.15
2400	553	0.65	585	0.71	617	0.78	649	0.85	680	0.91	711	0.98	740	1.04	769	1.1	796	1.15	821	1.21
2500	570	0.71	602	0.78	633	0.84	665	0.91	695	0.97	725	1.04	753	1.1	781	1.16	807	1.22	832	1.27
2600	588	0.77	619	0.84	650	0.91	680	0.97	710	1.04	739	1.1	767	1.16	793	1.22	818	1.28	842	1.33
2700	607	0.84	637	0.91	667	0.97	697	1.04	726	1.11	753	1.17	780	1.23	806	1.29	830	1.35	854	1.4
2800	626	0.91	655	0.97	684	1.04	713	1.11	741	1.18	768	1.24	794	1.3	819	1.36	842	1.42	866	1.47
2900	646	0.98	674	1.05	702	1.11	730	1.18	757	1.25	783	1.32	808	1.38	832	1.44	855	1.49	878	1.54

Air Volume (cfm)	External Static (in.w.g.)																			
	1.1		1.2		1.3		1.4		1.5		1.6		1.7		1.8		1.9		2.0	
	RPM	BHP	RPM	BHP	RPM	BHP	RPM	BHP	RPM	BHP	RPM	BHP	RPM	BHP	RPM	BHP	RPM	BHP	RPM	BHP
1900	807	1	832	1.04	857	1.07	883	1.11	912	1.14	941	1.17	968	1.21	993	1.25	1017	1.29	1039	1.34
2000	813	1.04	838	1.08	862	1.12	889	1.15	917	1.19	945	1.22	972	1.26	997	1.3	1020	1.35	1042	1.4
2100	820	1.09	844	1.13	869	1.17	895	1.21	923	1.24	951	1.28	977	1.32	1001	1.36	1024	1.41	1046	1.46
2200	828	1.14	852	1.18	877	1.22	903	1.26	930	1.3	957	1.33	983	1.37	1006	1.42	1028	1.47	1050	1.53
2300	836	1.2	861	1.24	885	1.28	911	1.31	938	1.35	964	1.39	989	1.43	1012	1.48	1033	1.54	1054	1.6
2400	846	1.25	870	1.29	895	1.33	920	1.37	947	1.41	972	1.45	996	1.5	1018	1.55	1039	1.61	1059	1.67
2500	856	1.31	880	1.35	905	1.39	930	1.43	956	1.47	980	1.52	1003	1.57	1024	1.63	1044	1.69	1064	1.76
2600	866	1.38	891	1.42	915	1.46	940	1.5	965	1.54	988	1.59	1010	1.65	1031	1.71	1050	1.78	1069	1.84
2700	878	1.44	902	1.48	926	1.52	950	1.57	974	1.61	997	1.67	1018	1.73	1037	1.8	1056	1.87	1075	1.93
2800	889	1.51	913	1.55	937	1.59	961	1.64	984	1.69	1006	1.75	1026	1.82	1044	1.89	1063	1.96	1081	2.03
2900	902	1.58	925	1.63	949	1.67	972	1.72	994	1.78	1015	1.84	1034	1.91	1052	1.99	1069	2.06	1087	2.13

BLOWER DATA

BELT DRIVE | 6 TON | HORIZONTAL

BLOWER TABLE INCLUDES RESISTANCE FOR BASE UNIT ONLY WITH DRY INDOOR COIL AND AIR FILTERS IN PLACE.

FOR ALL UNITS ADD:

- 1 - Any factory installed options air resistance (heat section, economizer, etc.).
- 2 - Any field installed accessories air resistance (duct resistance, diffuser, etc.).

See Page 40 for blower motors and drives and wet coil and options/accessory air resistance data.

Air Volume (cfm)	External Static (in.w.g.)																			
	0.10		0.20		0.30		0.40		0.50		0.60		0.70		0.80		0.9		1.0	
	RPM	BHP	RPM	BHP	RPM	BHP	RPM	BHP	RPM	BHP	RPM	BHP	RPM	BHP	RPM	BHP	RPM	BHP	RPM	BHP
1900	507	0.55	538	0.58	571	0.6	604	0.63	639	0.66	673	0.7	707	0.74	740	0.78	772	0.82	802	0.86
2000	522	0.59	554	0.62	586	0.64	620	0.67	653	0.71	687	0.74	720	0.78	752	0.82	783	0.87	812	0.91
2100	539	0.63	571	0.66	603	0.69	636	0.72	669	0.75	702	0.79	734	0.83	765	0.88	795	0.92	823	0.97
2200	557	0.68	588	0.71	620	0.74	652	0.77	685	0.81	717	0.84	748	0.89	778	0.93	807	0.98	834	1.03
2300	576	0.73	607	0.76	638	0.79	670	0.83	701	0.86	733	0.9	763	0.95	792	0.99	820	1.04	846	1.09
2400	596	0.79	626	0.82	657	0.85	688	0.89	718	0.92	749	0.96	778	1.01	806	1.06	833	1.11	858	1.16
2500	616	0.85	645	0.88	676	0.91	706	0.95	736	0.99	765	1.03	794	1.08	821	1.13	847	1.18	871	1.23
2600	636	0.91	665	0.94	695	0.98	724	1.02	754	1.06	782	1.1	809	1.15	836	1.2	861	1.25	885	1.3
2700	657	0.97	685	1.01	714	1.04	743	1.08	771	1.13	799	1.17	826	1.22	851	1.27	875	1.32	899	1.37
2800	677	1.03	706	1.07	734	1.11	762	1.16	790	1.2	816	1.25	842	1.3	867	1.35	890	1.4	913	1.45
2900	698	1.1	726	1.14	754	1.19	781	1.23	808	1.28	834	1.33	859	1.38	883	1.43	906	1.48	928	1.54

Air Volume (cfm)	External Static (in.w.g.)																			
	1.1		1.2		1.3		1.4		1.5		1.6		1.7		1.8		1.9		2.0	
	RPM	BHP	RPM	BHP	RPM	BHP	RPM	BHP	RPM	BHP	RPM	BHP	RPM	BHP	RPM	BHP	RPM	BHP	RPM	BHP
1900	830	0.91	857	0.95	883	0.99	910	1.04	937	1.09	964	1.13	991	1.18	1017	1.23	1042	1.28	1067	1.34
2000	839	0.96	865	1	891	1.05	917	1.09	944	1.14	970	1.19	996	1.24	1022	1.29	1047	1.34	1071	1.4
2100	849	1.02	874	1.06	900	1.11	926	1.15	952	1.2	978	1.25	1003	1.3	1028	1.35	1052	1.41	1075	1.46
2200	860	1.08	885	1.12	910	1.17	935	1.21	960	1.26	986	1.31	1010	1.36	1034	1.42	1058	1.48	1081	1.53
2300	871	1.14	895	1.19	920	1.23	945	1.28	969	1.33	994	1.38	1018	1.43	1042	1.49	1065	1.55	1087	1.61
2400	883	1.21	907	1.25	931	1.3	955	1.35	979	1.4	1003	1.45	1027	1.51	1050	1.57	1072	1.63	1094	1.69
2500	895	1.28	919	1.32	942	1.37	966	1.42	990	1.48	1013	1.53	1036	1.59	1059	1.65	1081	1.71	1102	1.78
2600	908	1.35	931	1.4	955	1.45	978	1.5	1001	1.56	1024	1.62	1046	1.68	1068	1.74	1089	1.8	1110	1.87
2700	922	1.43	945	1.48	967	1.53	990	1.59	1013	1.65	1035	1.71	1056	1.77	1078	1.84	1099	1.9	1119	1.96
2800	936	1.51	958	1.56	980	1.62	1003	1.68	1025	1.74	1046	1.8	1067	1.87	1088	1.93	1109	2	1129	2.06
2900	950	1.6	972	1.66	994	1.72	1016	1.78	1037	1.84	1058	1.91	1079	1.97	1099	2.04	1119	2.11	1139	2.17

BLOWER DATA

BELT DRIVE KIT SPECIFICATIONS - 036-060

Model No.	Motor HP		No. of Speeds	Drive Kits and RPM Range					
	Nominal	Maximum		A01	A02	A03	A05	A06	A07
036	0.75	0.86	2	low 449-673 high 673-1010	---	---	---	---	---
	1	1.15	2	---	---	---	low 598-897 high 897-1346	---	---
048	0.75	0.86	2	---	low 497-673 high 745-1117	---	---	---	---
	2	2.3	2	---	---	---	---	low 714-953 high 1071-1429	---
060	1	1.15	2	---	---	low 555-833 high 833-1250	---	---	---
	2	2.3	2	---	---	---	---	---	low 808-1032 high 1212-1548

BELT DRIVE KIT SPECIFICATIONS - 072-074

Model No.	Motor HP		No. of Speeds	Drive Kits and RPM Range		
	Nominal	Maximum		AA01	AA02	AA03
072	1	1.15	1	522-784	---	---
	2	2.3	1	---	632-875	798-1105
074	1	1.15	2	522-784	---	---
	2	2.3	2	---	632-875	798-1105

FACTORY INSTALLED OPTIONS/FIELD INSTALLED ACCESSORY AIR RESISTANCE - in. w.g.

Air Volume cfm	Wet Indoor Coil			Dehumidification Coil	Electric Heat	Economizer	Filters	
	036	048	060, 072, 074				MERV 8	MERV 13

036-048 MODELS

800	0.01	0.01	---	0.00	0.01	0.04	0.04	0.05
1000	0.02	0.02	---	0.00	0.03	0.04	0.04	0.07
1200	0.03	0.04	---	0.01	0.06	0.04	0.04	0.07
1400	0.04	0.05	---	0.02	0.09	0.04	0.04	0.07
1600	0.05	0.06	---	0.03	0.12	0.04	0.04	0.07
1800	0.06	0.07	---	0.04	0.15	0.05	0.04	0.07
2000	0.08	0.09	---	0.04	0.18	0.05	0.05	0.08

060, 072, 074 MODELS

1000	---	---	0.02	0.00	0.01	0.04	0.03	0.05
1200	---	---	0.04	0.00	0.03	0.04	0.03	0.07
1400	---	---	0.05	0.01	0.06	0.04	0.04	0.07
1600	---	---	0.07	0.02	0.09	0.04	0.04	0.07
1800	---	---	0.08	0.02	0.12	0.05	0.05	0.07
2000	---	---	0.10	0.03	0.15	0.05	0.05	0.07
2200	---	---	0.11	0.04	0.18	0.05	0.05	0.08
2400	---	---	0.13	0.04	0.20	0.05	0.05	0.08
2600	---	---	0.15	0.05	0.22	0.06	0.05	0.08
2800	---	---	0.16	0.05	0.24	0.06	0.05	0.08
3000	---	---	0.18	0.06	0.28	0.06	0.05	0.08

POWER EXHAUST FAN PERFORMANCE

Return Air System Static Pressure in. w.g.	Air Volume Exhausted cfm
0.00	2000
0.05	1990
0.10	1924
0.15	1810
0.20	1664
0.25	1507
0.30	1350
0.35	1210

BLOWER DATA

CEILING DIFFUSERS AIR RESISTANCE (in. w.g.)

Air Volume cfm	RTD9-65S Step-Down Diffuser			FD9-65S Flush Diffuser	RTD11-95S Step-Down Diffuser			FD11-95S Flush Diffuser
	2 Ends Open	1 Side & 2 Ends Open	All Ends & Sides Open		2 Ends Open	1 Side & 2 Ends Open	All Ends & Sides Open	
800	0.15	0.13	0.11	0.11	---	---	---	---
1000	0.19	0.16	0.14	0.14	---	---	---	---
1200	0.25	0.20	0.17	0.17	---	---	---	---
1400	0.33	0.26	0.20	0.20	---	---	---	---
1600	0.43	0.32	0.20	0.24	---	---	---	---
1800	0.56	0.40	0.30	0.30	0.13	0.11	0.09	0.09
2000	0.73	0.50	0.36	0.36	0.15	0.13	0.11	0.10
2200	0.95	0.63	0.44	0.44	0.18	0.15	0.12	0.12
2400	---	----	---	---	0.21	0.18	0.15	0.14
2600	---	----	---	---	0.24	0.21	0.18	0.17
2800	---	----	---	---	0.27	0.24	0.21	0.20
3000	---	----	---	---	0.32	0.29	0.25	0.25

CEILING DIFFUSER AIR THROW DATA

Air Volume - cfm	¹ Effective Throw - ft.	
Model No.	RTD9-65S	FD9-65S
800	10 - 17	14 - 18
1000	10 - 17	15 - 20
1200	11 - 18	16 - 22
1400	12 - 19	17 - 24
1600	12 - 20	18 - 25
1800	13 - 21	20 - 28
2000	14 - 23	21 - 29
2200	16 - 25	22 - 30
Model No.	RTD11-95S	FD11-95S
2600	24 - 29	19 - 24
2800	25 - 30	20 - 28
3000	27 - 33	21 - 29

¹ Effective throw based on terminal velocities of 75 ft. per minute.

ELECTRICAL/ELECTRIC HEAT DATA
3 TON

Model No.		LCH036H4			
¹ Voltage - 60hz		208/230V - 1 Ph	208/230V - 3 Ph	460V - 3 Ph	575V - 3 Ph
Compressor	Rated Load Amps	14.2	8.8	4	3.4
	Locked Rotor Amps	78.1	70	31	27
Outdoor Fan Motor	Full Load Amps	4.1	4.1	2.1	1.6
Power Exhaust (1) 0.33 HP	Full Load Amps	2.4	2.4	1.3	1
Service Outlet 115V GFI (amps)		15	15	15	20
Indoor Blower Motor	Horsepower	0.5	0.5	0.5	0.5
	Full Load Amps	4.3	4.3	2.2	1.7
² Maximum Overcurrent Protection	Unit Only	40	25	15	15
	With (1) 0.33 HP Power Exhaust	40	30	15	15
³ Minimum Circuit Ampacity	Unit Only	27	20	10	8
	With (1) 0.33 HP Power Exhaust	29	22	11	9

ELECTRIC HEAT DATA

Electric Heat Voltage			208V	240V	208V	240V	480V	600V
² Maximum Overcurrent Protection	Unit+	7.5 kW	⁴ 40	45	⁴ 25	30	15	15
	Electric Heat	15 kW	⁴ 80	90	⁴ 45	60	30	25
³ Minimum Circuit Ampacity	Unit+	7.5 kW	40	45	25	28	15	12
	Electric Heat	15 kW	74	84	45	51	26	21
² Maximum Overcurrent Protection	Unit+	7.5 kW	⁴ 45	50	⁴ 30	35	20	15
	Electric Heat and (1) 0.33 HP Power Exhaust	15 kW	⁴ 80	90	⁴ 50	60	30	25
³ Minimum Circuit Ampacity	Unit+	7.5 kW	43	48	28	31	16	13
	Electric Heat and (1) 0.33 HP Power Exhaust	15 kW	77	87	48	54	27	22

ELECTRICAL ACCESSORIES

Disconnect	7.5 kW	20W21	20W21	20W21	20W21	20W21	20W21
	15 kW	20W21	20W21	20W21	20W21	20W21	20W21

NOTE - All units have a minimum Short Circuit Current Rating (SCCR) of 5000 amps.

¹ Extremes of operating range are plus and minus 10% of line voltage.

² HACR type breaker or fuse.

³ Refer to National or Canadian Electrical Code manual to determine wire, fuse and disconnect size requirements.

⁴ Factory installed circuit breaker not available.

ELECTRICAL/ELECTRIC HEAT DATA

3 TON

Model No.		LCH036S4					
¹ Voltage - 60hz		208/230V - 3 Ph		460V - 3 Ph		575V - 3 Ph	
Compressor	Rated Load Amps	8.8		4		3.4	
	Locked Rotor Amps	70		31		27	
Outdoor Fan Motor	Full Load Amps	0.9		0.6		0.5	
Power Exhaust (1) 0.33 HP	Full Load Amps	2.4		1.3		1	
Service Outlet 115V GFI (amps)		15		15		20	
Indoor Blower Motor	Horsepower	0.75	1	0.75	1	0.75	1
	Full Load Amps	3.5	4.6	1.6	2.1	1.3	1.7
² Maximum Overcurrent Protection	Unit Only	20	25	15	15	15	15
	With (1) 0.33 HP Power Exhaust	25	25	15	15	15	15
³ Minimum Circuit Ampacity	Unit Only	16	17	8	8	7	7
	With (1) 0.33 HP Power Exhaust	18	19	9	9	8	8

ELECTRIC HEAT DATA

Electric Heat Voltage			208V	240V	208V	240V	480V	480V	600V	600V
² Maximum Overcurrent Protection	Unit+	7.5 kW	⁴ 25	30	30	30	15	15	15	15
	Electric Heat	15 kW	⁴ 45	50	⁴ 45	60	25	30	20	25
³ Minimum Circuit Ampacity	Unit+	7.5 kW	24	27	26	29	14	14	11	12
	Electric Heat	15 kW	44	50	45	51	25	26	20	21
² Maximum Overcurrent Protection	Unit+	7.5 kW	30	30	⁴ 30	35	15	20	15	15
	Electric Heat and (1) 0.33 HP Power Exhaust	15 kW	⁴ 50	60	⁴ 50	60	30	30	25	25
³ Minimum Circuit Ampacity	Unit+	7.5 kW	27	30	29	32	15	16	12	13
	Electric Heat and (1) 0.33 HP Power Exhaust	15 kW	47	53	48	54	27	27	21	22

ELECTRICAL ACCESSORIES

Disconnect	7.5 kW	20W21	20W21	20W21	20W21	20W21	20W21	20W21	20W21
	15 kW	20W21	20W21	20W21	20W21	20W21	20W21	20W21	20W21

NOTE - All units have a minimum Short Circuit Current Rating (SCCR) of 5000 amps.

¹ Extremes of operating range are plus and minus 10% of line voltage.

² HACR type breaker or fuse.

³ Refer to National or Canadian Electrical Code manual to determine wire, fuse and disconnect size requirements.

⁴ Factory installed circuit breaker not available.

ELECTRICAL/ELECTRIC HEAT DATA
4 TON

Model No.		LCH048H4			
¹ Voltage - 60hz		208/230V - 1 Ph	208/230V - 3 Ph	460V - 3 Ph	575V - 3 Ph
Compressor	Rated Load Amps	17.1	11.7	5.7	4.9
	Locked Rotor Amps	109	123	60	41
Outdoor Fan Motor	Full Load Amps	4.1	4.1	2.1	1.6
Power Exhaust (1) 0.33 HP	Full Load Amps	2.4	2.4	1.3	1
Service Outlet 115V GFI (amps)		15	15	15	20
Indoor Blower Motor	Horsepower	0.75	0.75	0.75	0.75
	Full Load Amps	6.1	6.1	3.1	2.4
² Maximum Overcurrent Protection	Unit Only	45	35	15	15
	With (1) 0.33 HP Power Exhaust	50	35	15	15
³ Minimum Circuit Ampacity	Unit Only	32	25	13	11
	With (1) 0.33 HP Power Exhaust	34	28	14	12

ELECTRIC HEAT DATA

Electric Heat Voltage			208V	240V	208V	240V	480V	600V
² Maximum Overcurrent Protection	Unit+ 7.5 kW		⁴ 45	50	35	35	20	15
	Electric Heat 15 kW		⁴ 80	90	⁴ 50	60	30	25
³ Minimum Circuit Ampacity	Unit+ 7.5 kW		42	47	28	31	16	13
	Electric Heat 15 kW		76	86	47	53	27	22
² Maximum Overcurrent Protection	Unit+ 7.5 kW		50	50	35	35	20	15
	Electric Heat and (1) 0.33 HP Power Exhaust 15 kW		⁴ 80	90	⁴ 50	60	30	25
³ Minimum Circuit Ampacity	Unit+ 7.5 kW		45	50	31	34	17	14
	Electric Heat and (1) 0.33 HP Power Exhaust 15 kW		79	89	50	56	29	23

ELECTRICAL ACCESSORIES

Disconnect	7.5 kW	20W21	20W21	20W21	20W21	20W21	20W21
	15 kW	20W22	20W22	20W21	20W21	20W21	20W21

NOTE - All units have a minimum Short Circuit Current Rating (SCCR) of 5000 amps.

¹ Extremes of operating range are plus and minus 10% of line voltage.

² HACR type breaker or fuse.

³ Refer to National or Canadian Electrical Code manual to determine wire, fuse and disconnect size requirements.

⁴ Factory installed circuit breaker not available.

ELECTRICAL/ELECTRIC HEAT DATA

4 TON

Model No.		LCH048S4					
¹ Voltage - 60hz		208/230V - 3 Ph		460V - 3 Ph		575V - 3 Ph	
Compressor	Rated Load Amps	11.7		5.7		4.9	
	Locked Rotor Amps	123		60		41	
Outdoor Fan Motor	Full Load Amps	1.7		1.1		0.7	
Power Exhaust\ (1) 0.33 HP	Full Load Amps	2.4		1.3		1	
Service Outlet 115V GFI (amps)		15		15		20	
Indoor Blower Motor	Horsepower	0.75	2	0.75	2	0.75	2
	Full Load Amps	3.5	7.5	1.6	3.4	1.3	2.7
² Maximum Overcurrent Protection	Unit Only	30	35	15	15	15	15
	With (1) 0.33 HP Power Exhaust	30	35	15	15	15	15
³ Minimum Circuit Ampacity	Unit Only	20	24	10	12	9	10
	With (1) 0.33 HP Power Exhaust	23	27	12	13	10	11

ELECTRIC HEAT DATA

Electric Heat Voltage			208V	240V	208V	240V	480V	480V	600V	600V
² Maximum Overcurrent Protection	Unit+	7.5 kW	30	30	35	35	15	20	15	15
	Electric Heat	15 kW	⁴ 45	50	⁴ 50	60	25	30	20	25
³ Minimum Circuit Ampacity	Unit+	7.5 kW	24	27	29	32	14	16	11	13
	Electric Heat	15 kW	44	50	49	55	25	27	20	22
² Maximum Overcurrent Protection	Unit+	7.5 kW	30	30	35	35	15	20	15	15
	Electric Heat and (1) 0.33 HP Power Exhaust	15 kW	⁴ 50	60	60	60	30	30	25	25
³ Minimum Circuit Ampacity	Unit+	7.5 kW	27	30	32	35	15	18	12	14
	Electric Heat and (1) 0.33 HP Power Exhaust	15 kW	47	53	52	58	27	29	21	23

ELECTRICAL ACCESSORIES

Disconnect	7.5 kW	20W21	20W21	20W21	20W21	20W21	20W21	20W21	20W21	20W21
	15 kW	20W21	20W21	20W21	20W21	20W21	20W21	20W21	20W21	20W21

NOTE - All units have a minimum Short Circuit Current Rating (SCCR) of 5000 amps.

¹ Extremes of operating range are plus and minus 10% of line voltage.

² HACR type breaker or fuse.

³ Refer to National or Canadian Electrical Code manual to determine wire, fuse and disconnect size requirements.

⁴ Factory installed circuit breaker not available.

ELECTRICAL/ELECTRIC HEAT DATA

5 TON

Model No.		LCH060H4			
¹ Voltage - 60hz		208/230V - 1 Ph	208/230V - 3 Ph	460V - 3 Ph	575V - 3 Ph
Compressor	Rated Load Amps	23.5	14	6.5	4.9
	Locked Rotor Amps	118	93	60	41
Outdoor Fan Motor	Full Load Amps	4.1	4.1	2.1	1.6
Power Exhaust (1) 0.33 HP	Full Load Amps	2.4	2.4	1.3	1
Service Outlet 115V GFI (amps)		15	15	15	20
Indoor Blower Motor	Horsepower	1	1	1	1
	Full Load Amps	7.4	7.4	3.7	3
² Maximum Overcurrent Protection	Unit Only	60	40	20	15
	With (1) 0.33 HP Power Exhaust	60	45	20	15
³ Minimum Circuit Ampacity	Unit Only	41	29	14	11
	With (1) 0.33 HP Power Exhaust	44	32	16	12

ELECTRIC HEAT DATA

Electric Heat Voltage			208V	240V	208V	240V	480V	600V
² Maximum Overcurrent Protection	Unit+ Electric Heat	7.5 kW	60	60	40	40	20	15
		15 kW	⁴ 80	90	⁴ 50	60	30	25
		22.5 kW	⁴ 125	150	⁴ 70	80	40	35
³ Minimum Circuit Ampacity	Unit+ Electric Heat	7.5 kW	44	49	29	32	16	13
		15 kW	77	88	49	55	28	22
		22.5 kW	111	127	68	77	39	31
² Maximum Overcurrent Protection	Unit+ Electric Heat and (1) 0.33 HP Power Exhaust	7.5 kW	60	60	45	45	20	15
		15 kW	⁴ 80	100	60	60	30	25
		22.5 kW	⁴ 125	150	80	80	45	35
³ Minimum Circuit Ampacity	Unit+ Electric Heat and (1) 0.33 HP Power Exhaust	7.5 kW	47	52	32	35	18	15
		15 kW	80	91	52	58	29	24
		22.5 kW	114	130	71	80	41	33

ELECTRICAL ACCESSORIES

Disconnect	7.5 kW	20W24	20W24	20W24	20W24	20W24	20W24
	15 kW	20W25	20W25	20W24	20W24	20W24	20W24
	22.5 kW	20W25	20W25	20W24	20W24	20W24	20W24

NOTE - All units have a minimum Short Circuit Current Rating (SCCR) of 5000 amps.

¹ Extremes of operating range are plus and minus 10% of line voltage.

² HACR type breaker or fuse.

³ Refer to National or Canadian Electrical Code manual to determine wire, fuse and disconnect size requirements.

⁴ Factory installed circuit breaker not available.

ELECTRICAL/ELECTRIC HEAT DATA

5 TON

Model No.		LCH060S4					
¹ Voltage - 60hz		208/230V - 3 Ph		460V - 3 Ph		575V - 3 Ph	
Compressor	Rated Load Amps	14		6.5		4.9	
	Locked Rotor Amps	93		60		41	
Outdoor Fan Motor	Full Load Amps	2.4		1.3		1	
Power Exhaust (1) 0.33 HP	Full Load Amps	2.4		1.3		1	
Service Outlet 115V GFI (amps)		15		15		20	
Indoor Blower Motor	Horsepower	1	2	1	2	1	2
	Full Load Amps	4.6	7.5	2.1	3.4	1.7	2.7
² Maximum Overcurrent Protection	Unit Only	35	40	15	15	15	15
	With (1) 0.33 HP Power Exhaust	40	40	15	20	15	15
³ Minimum Circuit Ampacity	Unit Only	25	28	12	13	9	10
	With (1) 0.33 HP Power Exhaust	27	30	13	15	10	11

ELECTRIC HEAT DATA

Electric Heat Voltage			208V	240V	208V	240V	480V	480V	600V	600V
² Maximum Overcurrent Protection	Unit+	7.5 kW	35	35	40	40	15	20	15	15
	Electric Heat	15 kW	⁴ 45	60	⁴ 50	60	30	30	25	25
		22.5 kW	⁴ 70	80	⁴ 70	80	40	40	30	35
³ Minimum Circuit Ampacity	Unit+	7.5 kW	26	29	29	32	14	16	12	13
	Electric Heat	15 kW	45	51	49	55	26	27	21	22
		22.5 kW	65	74	69	78	37	39	30	31
² Maximum Overcurrent Protection	Unit+	7.5 kW	40	40	40	40	20	20	15	15
	Electric Heat and (1) 0.33 HP Power Exhaust	15 kW	⁴ 50	60	60	60	30	30	25	25
		22.5 kW	⁴ 70	80	⁴ 80	90	40	40	35	35
³ Minimum Circuit Ampacity	Unit+	7.5 kW	29	32	32	35	16	18	13	14
	Electric Heat and (1) 0.33 HP Power Exhaust	15 kW	48	54	52	58	27	29	22	23
		22.5 kW	68	77	72	81	39	40	31	32

ELECTRICAL ACCESSORIES

Disconnect	7.5 kW	20W24	20W24	20W24	20W24	20W24	20W24	20W24	20W24
	15 kW	20W24	20W24	20W24	20W24	20W24	20W24	20W24	20W24
	22.5 kW	20W24	20W24	20W24	20W24	20W24	20W24	20W24	20W24

NOTE - All units have a minimum Short Circuit Current Rating (SCCR) of 5000 amps.

¹ Extremes of operating range are plus and minus 10% of line voltage.

² HACR type breaker or fuse.

³ Refer to National or Canadian Electrical Code manual to determine wire, fuse and disconnect size requirements.

⁴ Factory installed circuit breaker not available.

ELECTRICAL/ELECTRIC HEAT DATA

6 TON

Model No.		LCH072H4					
¹ Voltage - 60hz		208/230V - 3 Ph		460V - 3 Ph		575V - 3 Ph	
Compressor	Rated Load Amps	19.6		8.2		6.6	
	Locked Rotor Amps	136		66.1		55.3	
Outdoor Fan Motor	Full Load Amps	2.4		1.3		1	
Power Exhaust (1) 0.33 HP	Full Load Amps	2.4		1.3		1	
Service Outlet 115V GFI (amps)		15		15		20	
Indoor Blower Motor	Horsepower	1	2	1	2	1	2
	Full Load Amps	4.6	7.5	2.1	3.4	1.7	2.7
² Maximum Overcurrent Protection	Unit Only	50	50	20	20	15	15
	With (1) 0.33 HP Power Exhaust	50	50	20	20	15	15
³ Minimum Circuit Ampacity	Unit Only	32	35	14	15	11	12
	With (1) 0.33 HP Power Exhaust	34	37	15	17	12	13

ELECTRIC HEAT DATA

Electric Heat Voltage			208V	240V	208V	240V	480V	480V	600V	600V
² Maximum Overcurrent Protection	Unit+ Electric Heat	7.5 kW	50	50	50	50	20	20	15	15
		15 kW	⁴ 50	60	⁴ 50	60	30	30	25	25
		22.5 kW	⁴ 70	80	⁴ 70	80	40	40	30	35
		30 kW	⁴ 90	100	⁴ 90	100	50	50	40	40
³ Minimum Circuit Ampacity	Unit+ Electric Heat	7.5 kW	32	32	35	35	14	16	12	13
		15 kW	45	51	49	55	26	27	21	22
		22.5 kW	65	74	69	78	37	39	30	31
		30 kW	84	96	88	100	48	50	39	40
² Maximum Overcurrent Protection	Unit+ Electric Heat and (1) 0.33 HP Power Exhaust	7.5 kW	50	50	50	50	20	20	15	15
		15 kW	⁴ 50	60	60	60	30	30	25	25
		22.5 kW	⁴ 70	80	⁴ 80	90	40	40	35	35
		30 kW	⁴ 90	100	⁴ 100	110	50	60	40	45
³ Minimum Circuit Ampacity	Unit+ Electric Heat and (1) 0.33 HP Power Exhaust	7.5 kW	34	34	37	37	16	18	13	14
		15 kW	48	54	52	58	27	29	22	23
		22.5 kW	68	77	72	81	39	40	31	32
		30 kW	87	99	91	103	50	51	40	41

ELECTRICAL ACCESSORIES

Disconnect	7.5 kW	20W24	20W24	20W24	20W24	20W24	20W24	20W24	20W24
	15 kW	20W24	20W24	20W24	20W24	20W24	20W24	20W24	20W24
	22.5 kW	20W24	20W24	20W24	20W24	20W24	20W24	20W24	20W24
	30 kW	20W25	20W25	20W25	20W24	20W24	20W24	20W24	20W24

NOTE - All units have a minimum Short Circuit Current Rating (SCCR) of 5000 amps.

¹ Extremes of operating range are plus and minus 10% of line voltage.

² HACR type breaker or fuse.

³ Refer to National or Canadian Electrical Code manual to determine wire, fuse and disconnect size requirements.

⁴ Factory installed circuit breaker not available.

ELECTRICAL/ELECTRIC HEAT DATA

6 TON

Model No.		LCH074H4					
¹ Voltage - 60hz		208/230V - 3 Ph		460V - 3 Ph		575V - 3 Ph	
Compressor	Rated Load Amps	17.6		8.5		6.3	
	Locked Rotor Amps	136		66.1		55.3	
Outdoor Fan Motor	Full Load Amps	2.4		1.3		1	
Power Exhaust (1) 0.33 HP	Full Load Amps	2.4		1.3		1	
Service Outlet 115V GFI (amps)		15		15		20	
Indoor Blower Motor	Horsepower	1	2	1	2	1	2
	Full Load Amps	4.6	7.5	2.1	3.4	1.7	2.7
² Maximum Overcurrent Protection	Unit Only	45	45	20	20	15	15
	With (1) 0.33 HP Power Exhaust	45	50	20	25	15	15
³ Minimum Circuit Ampacity	Unit Only	29	32	15	16	11	12
	With (1) 0.33 HP Power Exhaust	32	35	16	17	12	13

ELECTRIC HEAT DATA

Electric Heat Voltage			208V	240V	208V	240V	480V	480V	600V	600V
² Maximum Overcurrent Protection	Electric Heat	Unit+ 7.5 kW	45	45	45	45	20	20	15	15
		15 kW	⁴ 45	60	⁴ 50	60	30	30	25	25
		22.5 kW	⁴ 70	80	⁴ 70	80	40	40	30	35
		30 kW	⁴ 90	100	⁴ 90	100	50	50	40	40
³ Minimum Circuit Ampacity	Electric Heat	Unit+ 7.5 kW	29	29	32	32	15	16	12	13
		15 kW	45	51	49	55	26	27	21	22
		22.5 kW	65	74	69	78	37	39	30	31
		30 kW	84	96	88	100	48	50	39	40
² Maximum Overcurrent Protection	Electric Heat and (1) 0.33 HP Power Exhaust	Unit+ 7.5 kW	45	45	50	50	20	25	15	15
		15 kW	⁴ 50	60	60	60	30	30	25	25
		22.5 kW	⁴ 70	80	⁴ 80	90	40	40	35	35
		30 kW	⁴ 90	100	⁴ 100	110	50	60	40	45
³ Minimum Circuit Ampacity	Electric Heat and (1) 0.33 HP Power Exhaust	Unit+ 7.5 kW	32	32	35	35	16	18	13	14
		15 kW	48	54	52	58	27	29	22	23
		22.5 kW	68	77	72	81	39	40	31	32
		30 kW	87	99	91	103	50	51	40	41

ELECTRICAL ACCESSORIES

Disconnect	7.5 kW	20W24	20W24	20W24	20W24	20W24	20W24	20W24	20W24
	15 kW	20W24	20W24	20W24	20W24	20W24	20W24	20W24	20W24
	22.5 kW	20W24	20W24	20W24	20W24	20W24	20W24	20W24	20W24
	30 kW	20W25	20W25	20W25	20W24	20W24	20W24	20W24	20W24

NOTE - All units have a minimum Short Circuit Current Rating (SCCR) of 5000 amps.

¹ Extremes of operating range are plus and minus 10% of line voltage.

² HACR type breaker or fuse.

³ Refer to National or Canadian Electrical Code manual to determine wire, fuse and disconnect size requirements.

⁴ Factory installed circuit breaker not available.

ELECTRIC HEAT CAPACITIES

Input Voltage	7.5 kW			15 kW			22.5 kW			30 kW		
	No of Stages	kW input	Btuh Output	No of Stages	kW input	Btuh Output	No of Stages	kW input	Btuh Output	No of Stages	kW input	Btuh Output
208	1	5.6	19,200	1	11.2	38,200	1	16.9	57,700	1	22.5	76,800
220	1	6.3	21,500	1	12.6	43,000	1	18.9	64,500	1	25.2	86,000
230	1	6.9	23,500	1	13.8	47,000	1	20.7	70,700	1	27.5	93,900
240	1	7.5	25,600	1	15	51,200	1	22.5	76,800	1	30	102,400
440	1	6.3	21,500	1	12.6	43,000	1	18.9	64,500	1	25.2	86,000
460	1	6.9	23,500	1	13.8	47,000	1	20.7	70,700	1	27.5	93,900
480	1	7.5	25,600	1	15	51,200	1	22.5	76,800	1	30	102,400
550	1	6.3	21,500	1	12.6	43,000	1	18.9	64,500	1	25.2	86,000
575	1	6.9	23,500	1	13.8	47,000	1	20.7	70,700	1	27.5	93,900
600	1	7.5	25,600	1	15	51,200	1	22.5	76,800	1	30	102,400

UNIT CLEARANCES

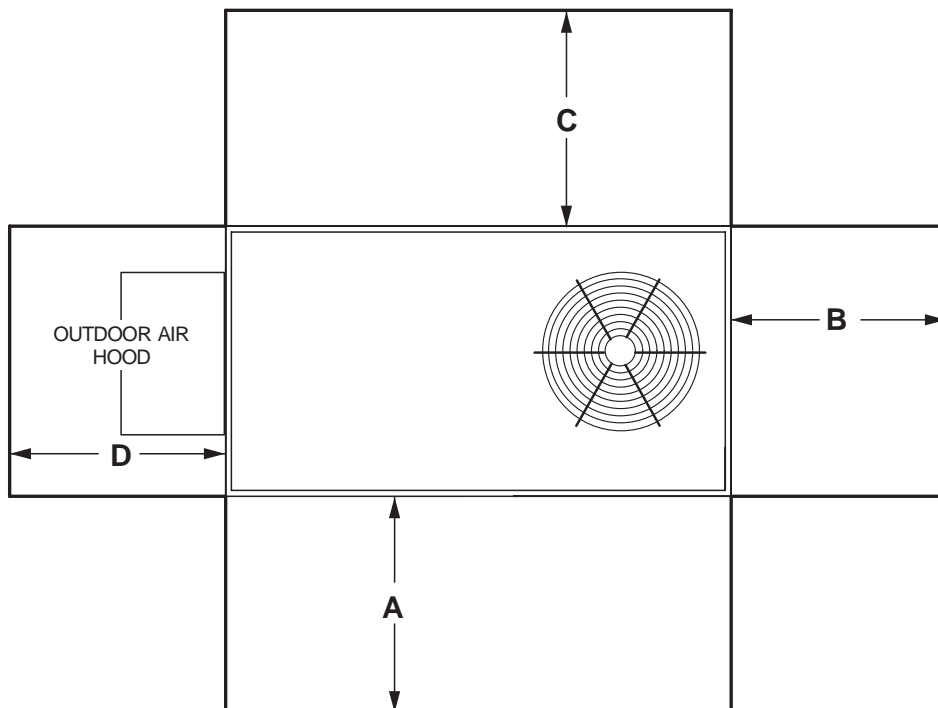

1 Unit Clearance	A		B		C		D		Top Clearance
	in.	mm	in.	mm	in.	mm	in.	mm	
Service Clearance	36	914	36	914	36	934	36	914	Unobstructed
Minimum Operation Clearance	36	914	36	914	36	914	36	914	

NOTE - Entire perimeter of unit base requires support when elevated above the mounting surface.

¹ Service Clearance - Required for removal of serviceable parts.

Minimum Operation Clearance - Required clearance for proper unit operation.

OUTDOOR SOUND DATA

1 Unit Model No.	Octave Band Sound Power Levels dBA, re 10 ⁻¹² Watts Center Frequency - Hz							1 Sound Rating Number dBA
	125	250	500	1000	2000	4000	8000	
036, 048	63	66	70	71	68	62	53	75
060, 072, 074	67	72	77	76	73	68	61	82

NOTE - The octave sound power data does not include tonal corrections.

¹ Sound Rating Number according to AHRI Standard 270-95 (includes pure tone penalty). Sound Rating Number is the overall A-Weighted Sound Power Level, (Lwa), dBA (100 Hz to 10,000 Hz).

WEIGHT DATA

Model Number	Outdoor Coil	Net		Shipping		Outdoor Coil	Net		Shipping	
		lbs.	kg	lbs.	kg		lbs.	kg	lbs.	kg
036 Base Unit	Eco-Last™	513	233	574	260	Fin/Tube	532	241	593	269
036 Max. Unit	Eco-Last™	723	328	784	356	Fin/Tube	742	337	803	364
048 Base Unit	Eco-Last™	529	240	590	268	Fin/Tube	562	255	623	283
048 Max. Unit	Eco-Last™	723	328	803	364	Fin/Tube	775	351	836	379
060 Base Unit	Eco-Last™	607	275	668	303	Fin/Tube	649	294	710	322
060 Max. Unit	Eco-Last™	844	383	905	410	Fin/Tube	886	402	947	430
072 Base Unit	Eco-Last™	684	310	745	338	Fin/Tube	726	329	787	357
072 Max. Unit	Eco-Last™	891	404	952	432	Fin/Tube	933	423	994	451
074 Base Unit	Eco-Last™	684	310	745	338	Fin/Tube	726	329	787	357
074 Max. Unit	Eco-Last™	891	404	952	432	Fin/Tube	933	423	994	451

OPTIONS / ACCESSORIES

		Shipping Weight	
		lbs.	kg.
ECONOMIZER / OUTDOOR AIR / EXHAUST			
Economizer			
Economizer, Includes Combination Outdoor Air Hood and Barometric Relief Dampers		131	59
Outdoor Air Dampers			
Motorized		40	18
Manual		30	14
Power Exhaust			
Standard Static		35	17
ELECTRIC HEAT			
		7.5 kW	14
		15 kW	14
		22.5 kW	16
		30 kW	16
PACKAGING			
LTL Packaging (less than truck load)		60	27
ROOF CURBS			
Hybrid Roof Curbs, Downflow			
8 in. height	C1CURB70A-1	50	23
14 in. height	C1CURB71A-1	70	32
18 in. height	C1CURB72A-1	80	36
24 in. height	C1CURB73A-1	100	45
Adjustable Pitch Curb, Downflow			
14 in. height		113	51
CEILING DIFFUSERS			
Step-Down	RTD9-65S	80	36
	RTD11-95S	118	54
Flush	FD9-65S	80	36
	FD11-95S	118	54
Transitions	T1TRAN10AN1	22	10
	T1TRAN20N-1	21	10
DEHUMIDIFICATION SYSTEM			
Dehumidification Option (Net Weight)		27	12

DIMENSIONS - UNIT

CORNER WEIGHTS

Model No.	CORNER WEIGHTS								CENTER OF GRAVITY			
	AA		BB		CC		DD		EE		FF	
	lbs.	kg	lbs.	kg	lbs.	kg	lbs.	kg	in.	mm	in.	mm
LCH036 Base Unit	92	42	112	51	180	82	148	67	38.5	978	18	457
LCH036 Max. Unit	133	61	151	69	243	110	215	98	40	1016	18	457
LCH048 Base Unit	97	44	118	54	190	87	157	71	38.5	978	18	457
LCH048 Max. Unit	139	63	158	72	254	115	224	102	40	1016	18	457
LCH060 Base Unit	112	51	136	62	219	100	181	82	38.5	978	18	457
LCH060 Max. Unit	159	72	180	82	290	132	257	117	40	1016	18	457
LCH072 Base Unit	126	57	152	69	246	112	202	92	38.5	978	18	457
LCH072 Max. Unit	168	76	190	86	306	139	270	123	40	1016	18	457
LCH074 Base Unit	126	57	152	69	246	112	202	92	38.5	978	18	457
LCH074 Max Unit	168	76	190	86	306	139	270	123	40	1016	18	457

Base Unit - The unit with NO INTERNAL OPTIONS.

Max. Unit - The unit with ALL INTERNAL OPTIONS Installed. (Economizer, Standard Static Power Exhaust Fans, Controls, etc.). Does not include accessories external to unit or high static power exhaust.

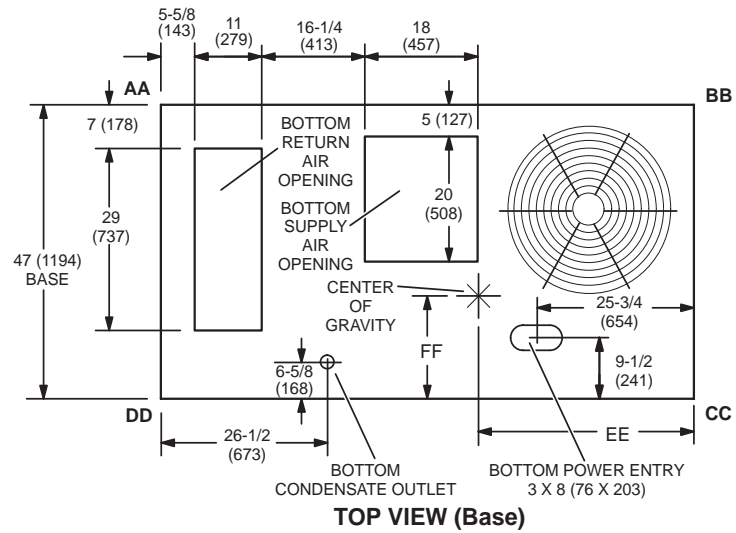

TOP VIEW (Base)

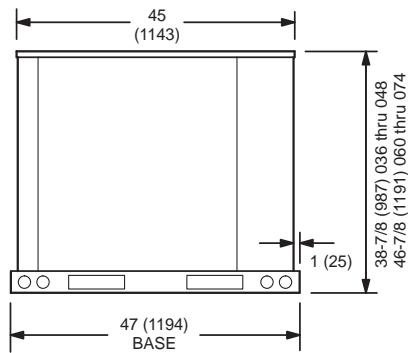

END VIEW

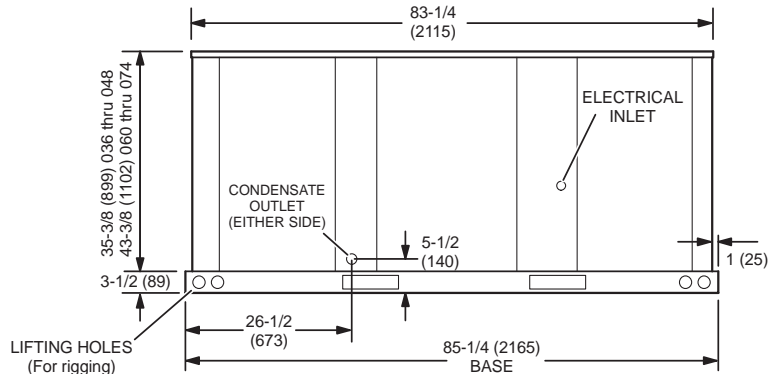

SIDE VIEW

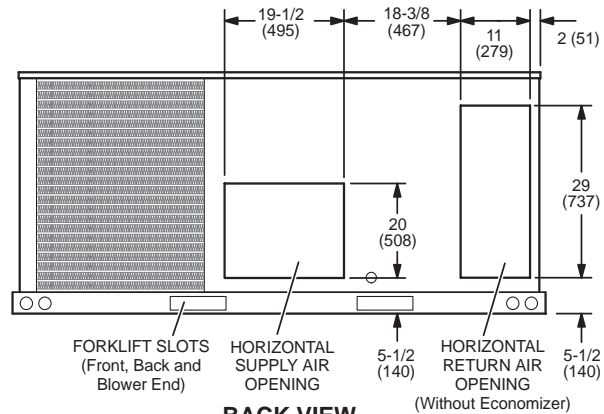

BACK VIEW

OUTDOOR AIR DAMPER HOOD DETAIL (Downflow or Horizontal Applications)

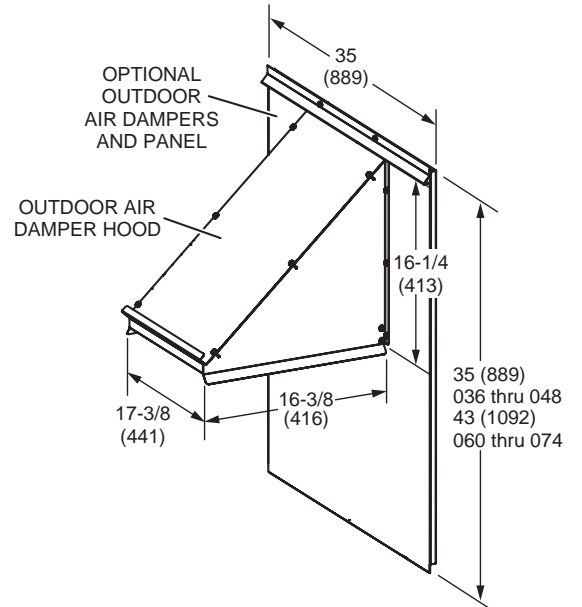
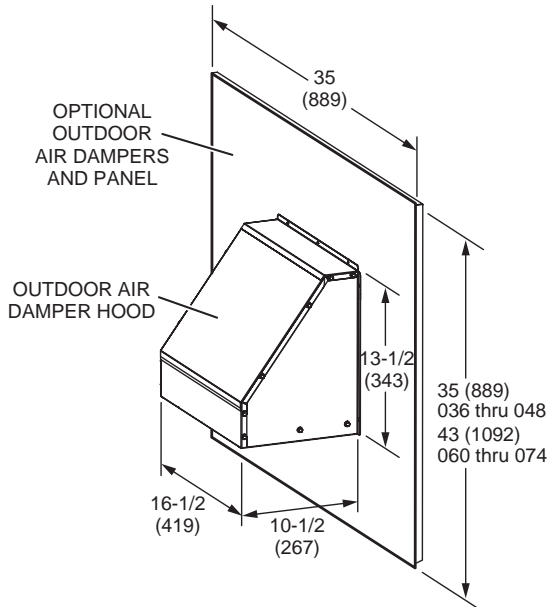
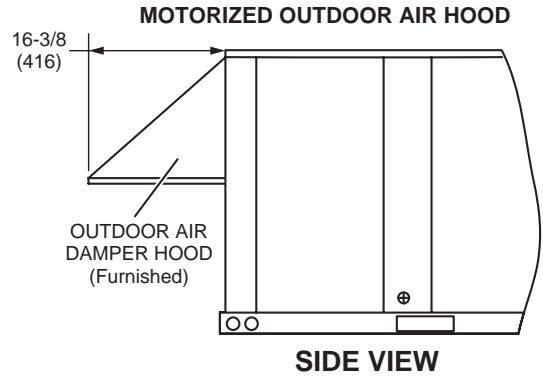
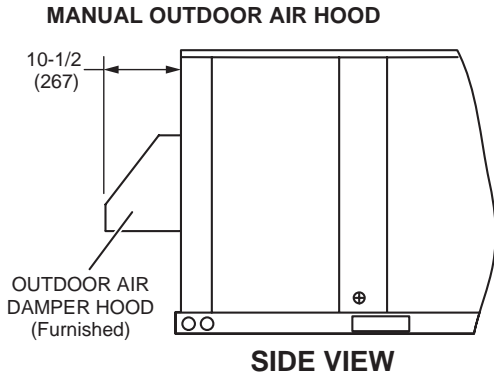

DIMENSIONS - ACCESSORIES

OUTDOOR AIR HOOD DETAIL WITH OPTIONAL ECONOMIZER AND OPTIONAL BAROMETRIC RELIEF DAMPERS WITH HOOD (Horizontal Application)

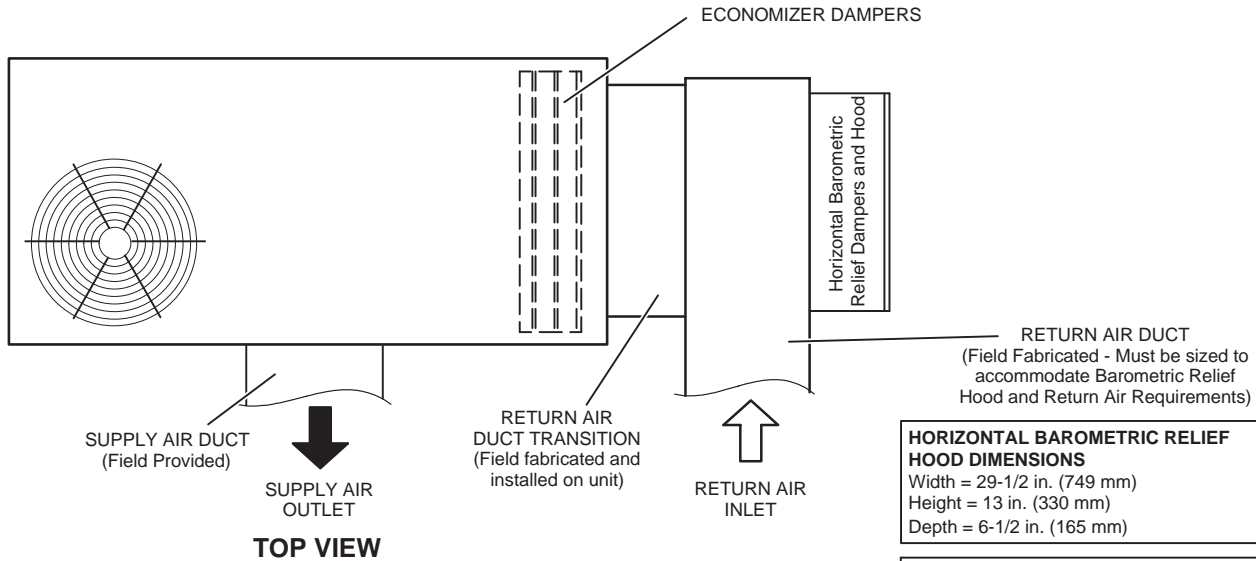

HORIZONTAL BAROMETRIC RELIEF HOOD DIMENSIONS
 Width = 29-1/2 in. (749 mm)
 Height = 13 in. (330 mm)
 Depth = 6-1/2 in. (165 mm)

NOTE - Horizontal applications with Economizer require **Horizontal Economizer Conversion Kit**. See Options/Accessories table.

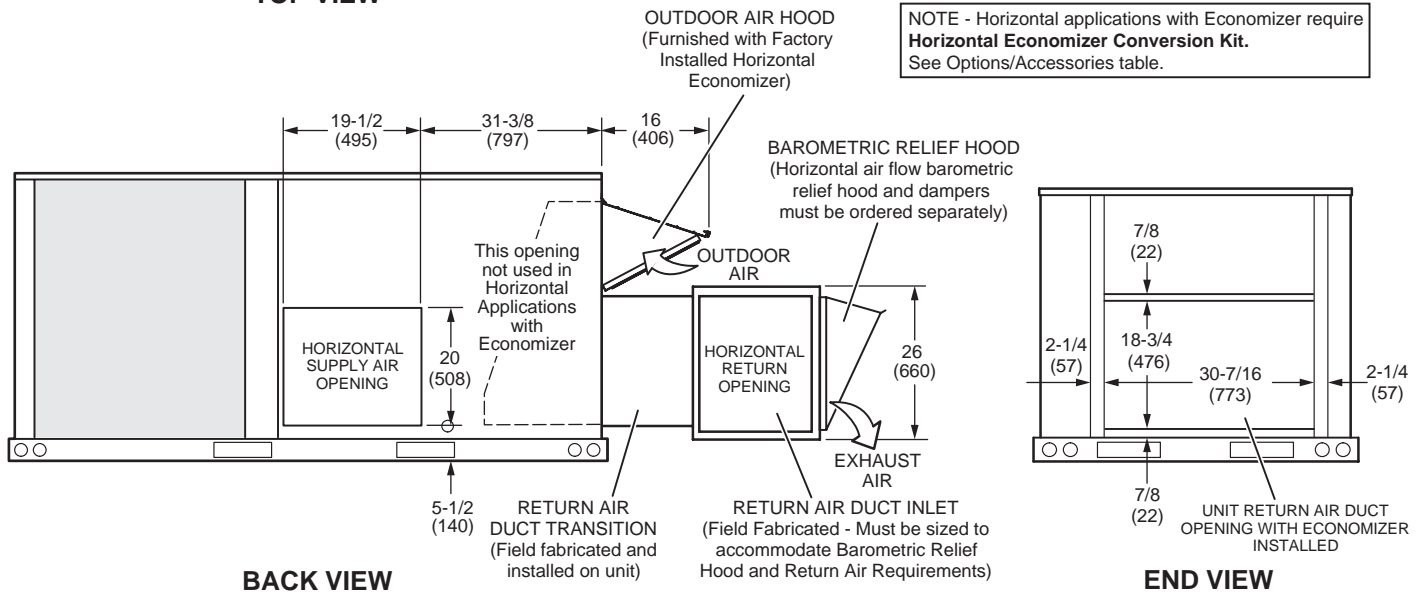

NOTE - Return Air Duct and Transition must be supported

DIMENSIONS - ACCESSORIES

HYBRID ROOF CURBS - DOUBLE DUCT OPENING

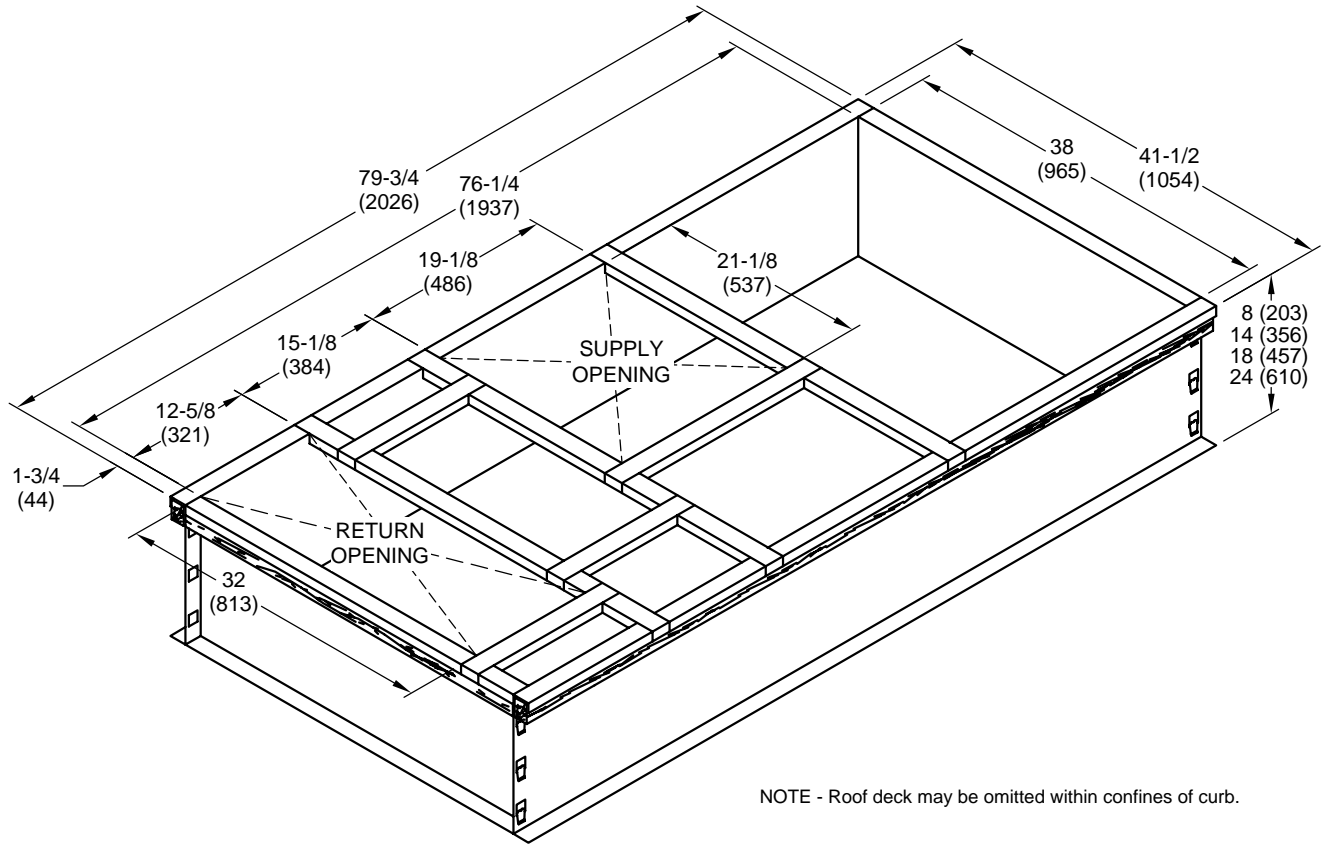

TYPICAL FLASHING DETAIL FOR ROOF CURB

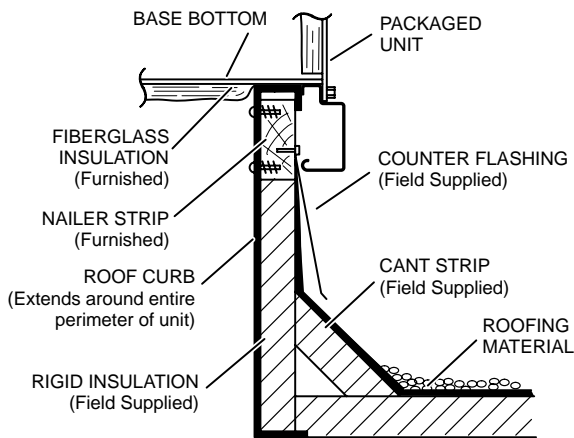

DETAIL ROOF CURB

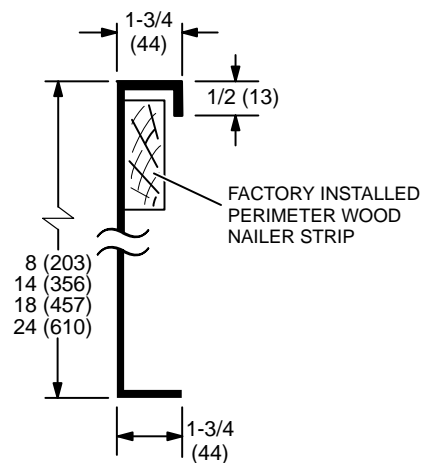

DIMENSIONS - ACCESSORIES

ADJUSTABLE PITCH CURBS - DOUBLE DUCT OPENING

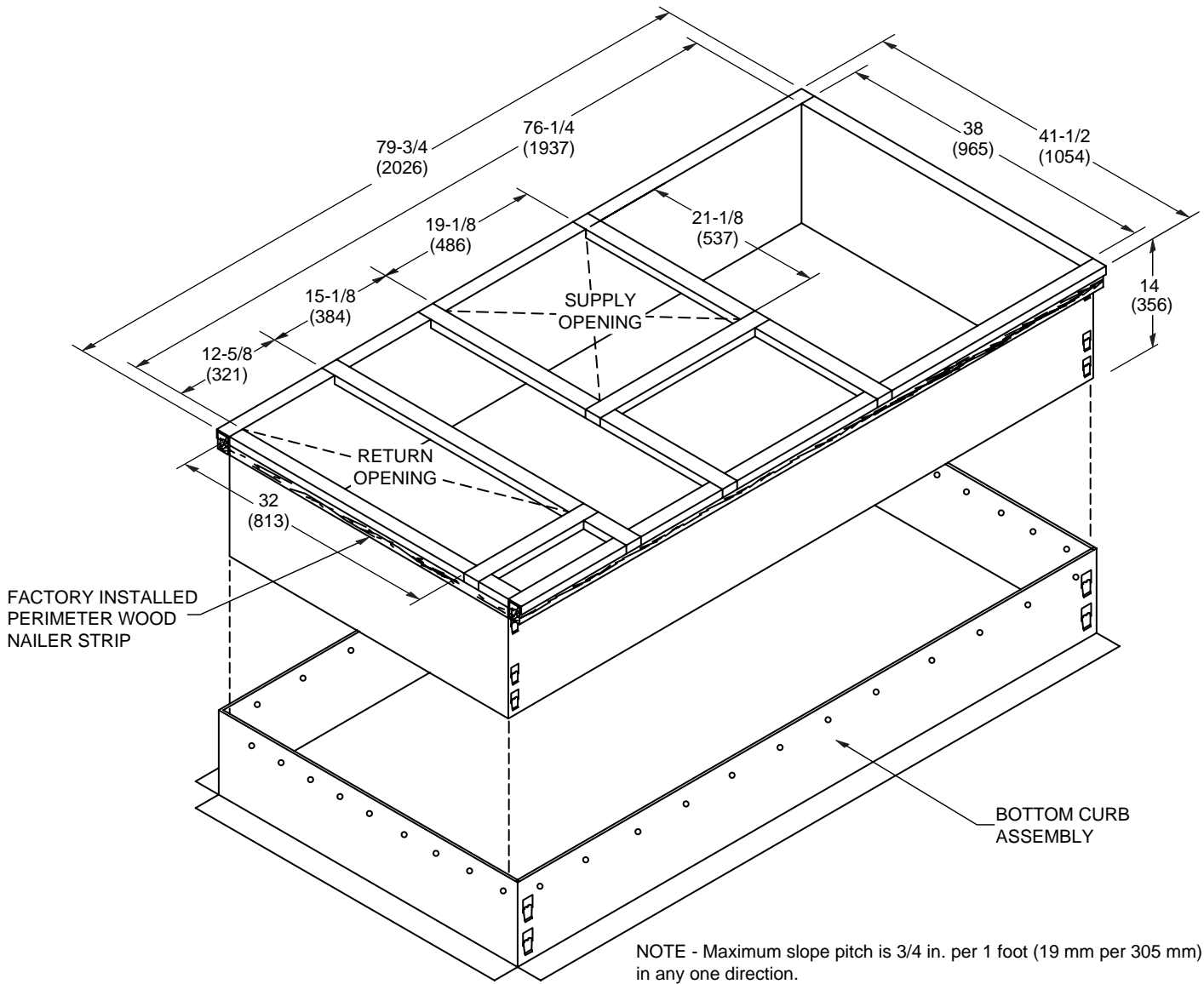

TYPICAL FLASHING DETAIL FOR ROOF CURB

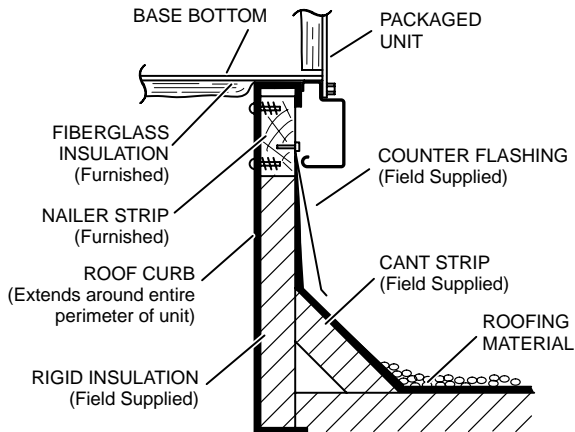

DETAIL ROOF CURB

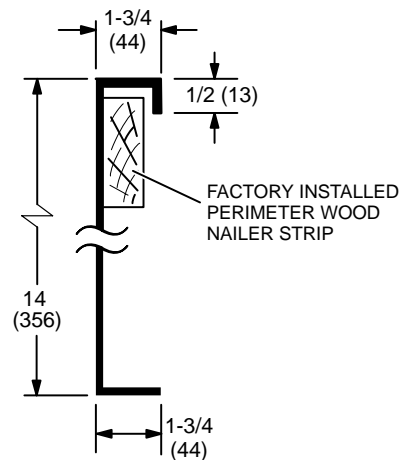

TRANSITIONS

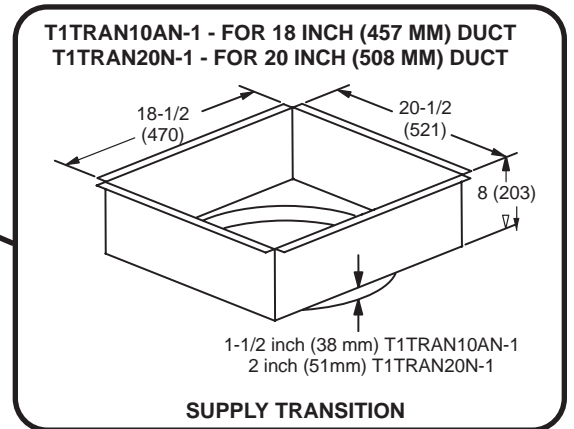
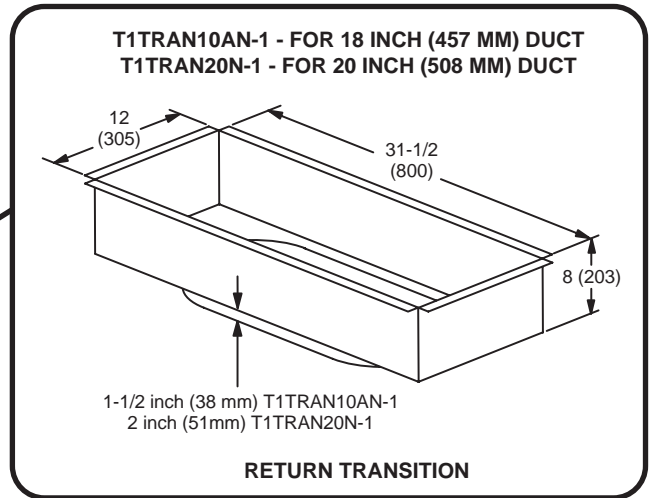
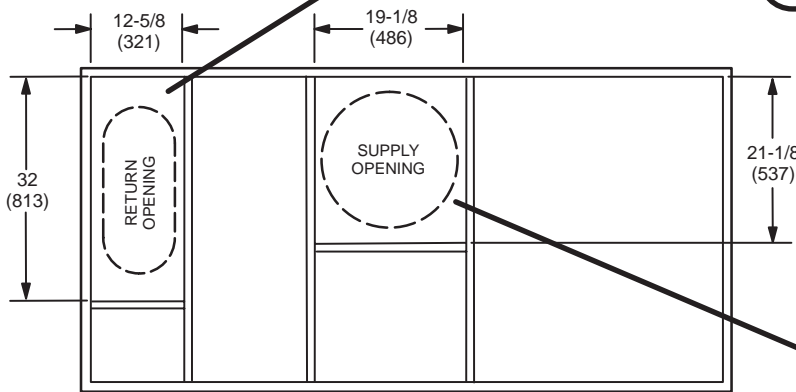

DIMENSIONS - ACCESSORIES

COMBINATION CEILING SUPPLY AND RETURN DIFFUSERS

STEP-DOWN CEILING DIFFUSER

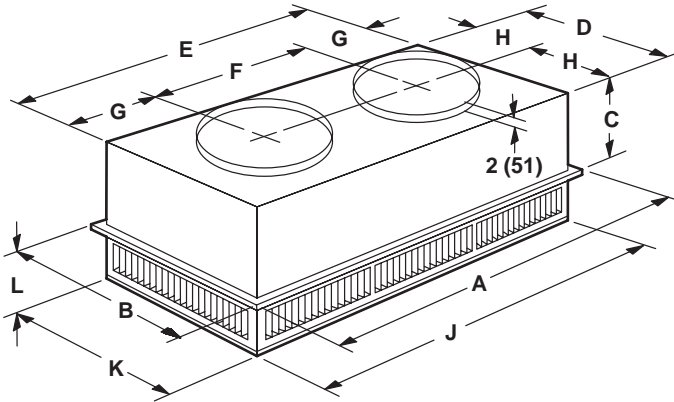

FLUSH CEILING DIFFUSER

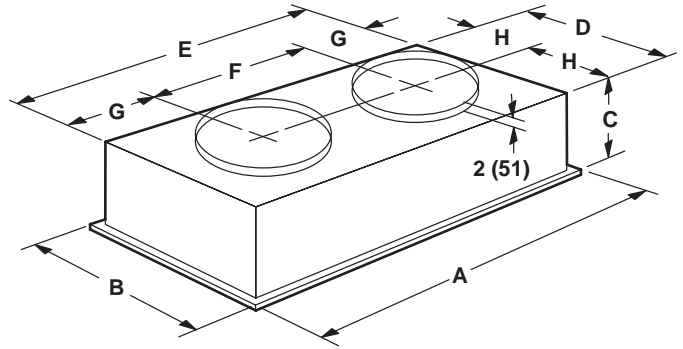

Model Number		RTD9-65S	RTD11-95S
A	in.	47-5/8	47-5/8
	mm	1159	1159
B	in.	23-5/8	29-5/8
	mm	600	752
C	in.	11-3/8	14-3/8
	mm	289	365
D	in.	21-1/2	27-1/2
	mm	546	699
E	in.	45-1/2	45-1/2
	mm	1156	1158
F	in.	22-1/2	22-1/2
	mm	572	572
G	in.	11-1/2	11-1/2
	mm	292	292
H	in.	10-3/4	13-3/4
	mm	273	349
J	in.	45-1/2	45-1/2
	mm	1156	1156
K	in.	21-1/2	27-1/2
	mm	546	699
L	in.	7-1/8	8-1/8
	mm	181	206
Duct Size	in.	18 round	20 round
	mm	457 round	508 round

Model Number		FD9-65S	FD11-95S
A	in.	47-5/8	47-5/8
	mm	1159	1159
B	in.	23-5/8	29-5/8
	mm	600	752
C	in.	13-1/2	16-5/8
	mm	343	422
D	in.	21	27
	mm	533	686
E	in.	45	45
	mm	1143	1143
F	in.	22-1/2	22-1/2
	mm	572	572
G	in.	11-1/4	11-1/4
	mm	286	286
H	in.	10-1/2	13-1/2
	mm	267	343
Duct Size	in.	18 round	20 round
	mm	457 round	508 round

REVISIONS

Section	Description
Electrical / Electric Heat Data	Updated tables for 3, 4, and 5 ton standard and high efficiency units.



Intertek



Visit us at www.allied-commercial.com

For the latest technical information, visit us at www.allied-commercial.com

Contact us at 1-800-448-5872

NOTE - Due to Allied Commercial ongoing commitment to quality, Specifications, Ratings and Dimensions subject to change without notice and without incurring liability. Improper installation, adjustment, alteration, service or maintenance can cause property damage or personal injury. Installation and service must be performed by a qualified installer and servicing agency.