

**INSTALLATION INSTRUCTIONS FOR SMOKE DETECTOR KITS
USED WITH KC/KG/KH024-090 & LCH/LGH036-072 UNITS**

Shipping and Packing List

53W78; 603408-01

Single-sensor kit contains the following:

- 1 - Smoke detector sensor
- 1 - Smoke detector power board
- 1 - Supply bracket
- 1 - Supply brace
- 1 - Return bracket (used on KC, KG & KH units only)
- 1 - Return brace (used on KC, KG & KH units only)
- 1 - Power harness
- 1 - Supply or return air harness
- 1 - Jumper harness
- 1 - Metal sampling tube
- 1 - Plastic exhaust tube
- 1 - Magnet
- 1 - Sensor manufacturer's instructions
- #10 - 16 X 3/4" sheet metal screws
- #8 - 32 X 1" thread-forming screws

53W79; 603408-02

Dual-sensor kit contains the following:

- 2 - Smoke detector sensors
- 1 - Smoke detector power board
- 1 - Supply bracket
- 1 - Supply brace
- 1 - Return bracket (used on KC, KG & KH units only)
- 1 - Return brace (used on KC, KG & KH units only)
- 1 - Power harness
- 1 - Supply and return air harness
- 2 - Metal sampling tubes
- 2 - Plastic exhaust tubes
- 2 - Magnets
- 1 - Sensor manufacturer's instructions
- #10 - 16 X 3/4" sheet metal screws
- #8 - 32 X 1" thread-forming screws

Application

LCH and LGH Units -- Smoke detector will send a 24Vac signal to the unit A55 IMC when smoke is sensed. IMC default mode will de-energize unit.

KC, KG and KH Units -- Smoke detector will interrupt the 24Vac signal to the unit control circuit when smoke is sensed. Unit will be de-energized.

Identify Harnesses

Three harnesses are provided in the single sensor kit and two harnesses are provided in the dual sensor kit. Use wire labels, length of harnesses and number and size of connectors to determine appropriate harnesses used in each application. Refer to figure 1 for 53W78 single sensor kits and figure 2 for 54W79 dual sensor kits.

Installation

⚠ WARNING

Improper installation, adjustment, alteration, service or maintenance can cause property damage, personal injury or loss of life. Installation and service must be performed by a licensed professional installer, service agency or the gas supplier.

⚠ CAUTION

Before attempting to perform any service or maintenance, turn the electrical power to unit OFF at disconnect switch.

⚠ CAUTION

Danger of sharp metallic edges. Can cause injury. Take care when servicing unit to avoid accidental contact with sharp edges.



**HARNESS IDENTIFICATION (not to scale)
53W78 SINGLE SENSOR KITS
(SUPPLY AIR ONLY OR RETURN AIR ONLY APPLICATIONS)**

POWER HARNESS - 2 FT. IN LENGTH
Used in KG/KC/KH applications.
Discard in LGH/LCH applications.

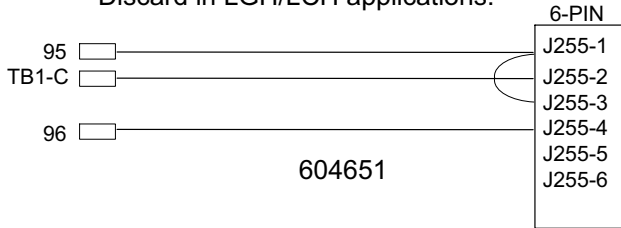

JUMPER HARNESS - 4" IN LENGTH
Used in LGH/LCH supply air only applications.
Discard harness in other applications.

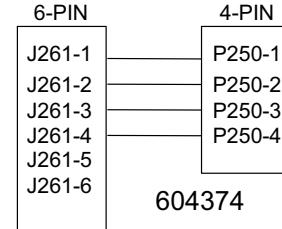

SUPPLY OR RETURN AIR HARNESS - APPROX. 10 FT. IN LENGTH
Use this harness in unit return air only AND KG/KC/KH supply air only applications.
Discard in LGH/LCH applications; harness is provided in unit.

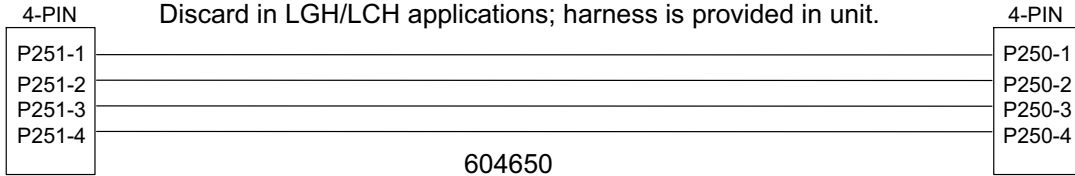
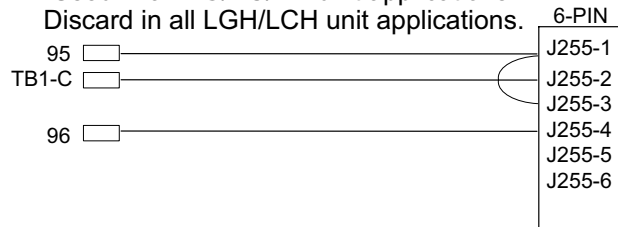

FIGURE 1

**HARNESS IDENTIFICATION (not to scale)
53W79 DUAL SENSOR KITS
(COMBINATION SUPPLY AIR AND RETURN AIR APPLICATIONS)**

POWER HARNESS - 2 FT. IN LENGTH
Used in all KG/KC/KH unit applications.
Discard in all LGH/LCH unit applications.



SUPPLY AND RETURN AIR HARNESS - 4 CONNECTORS
Used in all dual sensor applications.

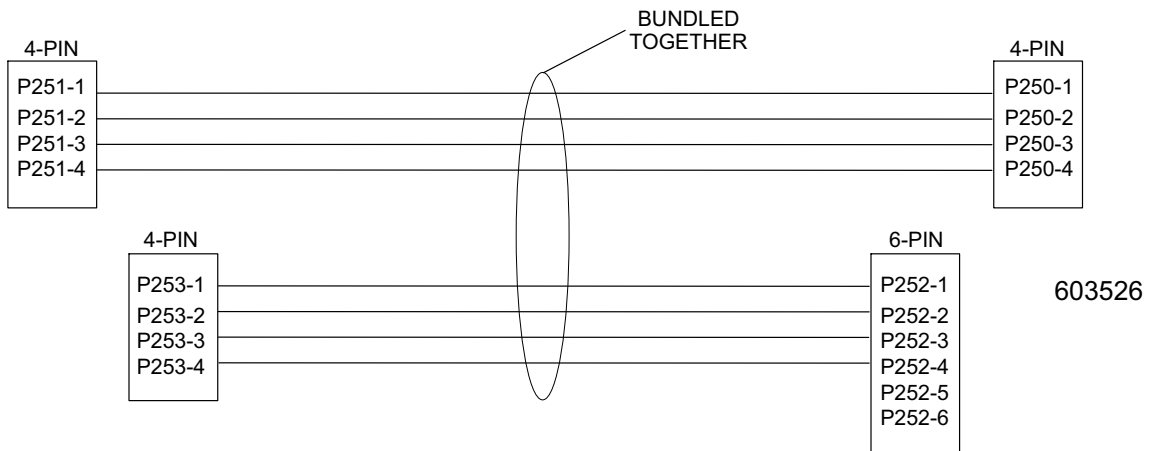

FIGURE 2

Installation - continued

Smoke detector sensor and power board installation

Use manufacturer's instructions provided with smoke detector to install sensor(s) and power board. Refer to figure 3 for location of power board, supply air sensor and return air sensor on units with an economizer. For location of return air sensor on units without an economizer, refer to figure 4 for KC, KG and KH units, and figure 5 for LCH and LGH units.

Sampling tube installation

- 1 - Slide metal sampling tube onto the back side of the sensor as shown in figure 6. When sensor is installed in return air applications, slide plastic exhaust tube onto back side of the sensor as shown in figure 6.
NOTE - Plastic exhaust tube is NOT used in supply air applications and should be discarded.
- 2 - Orient sampling tube so that holes point toward the air stream.

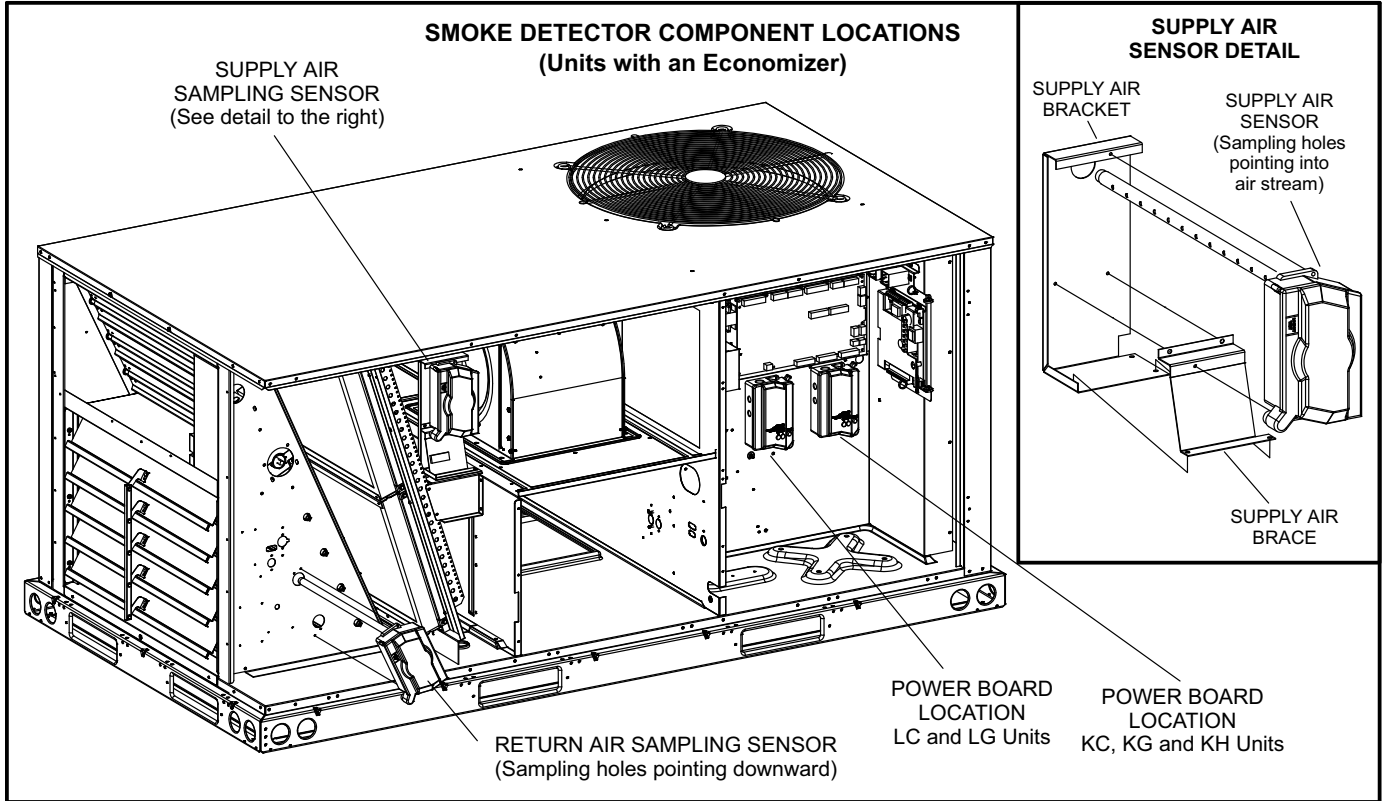

FIGURE 3

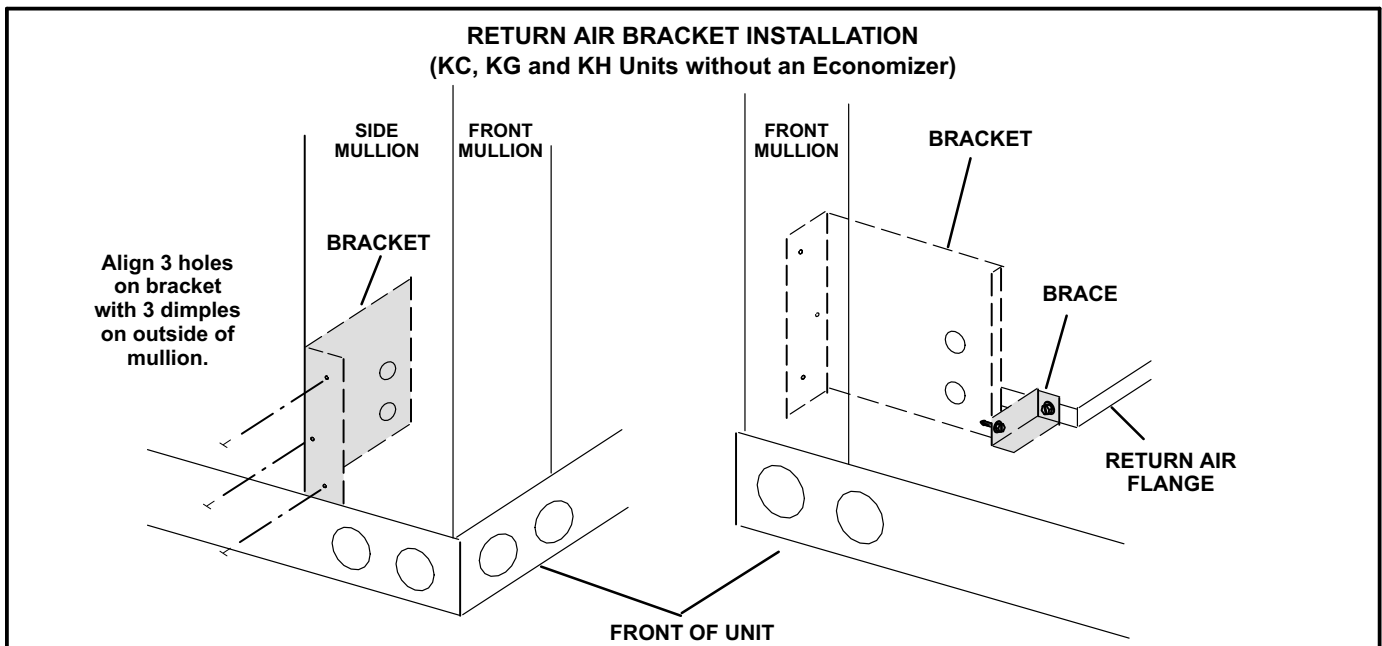

FIGURE 4

**SMOKE DETECTOR COMPONENT LOCATIONS
(LCH and LGH Units without an Economizer)**

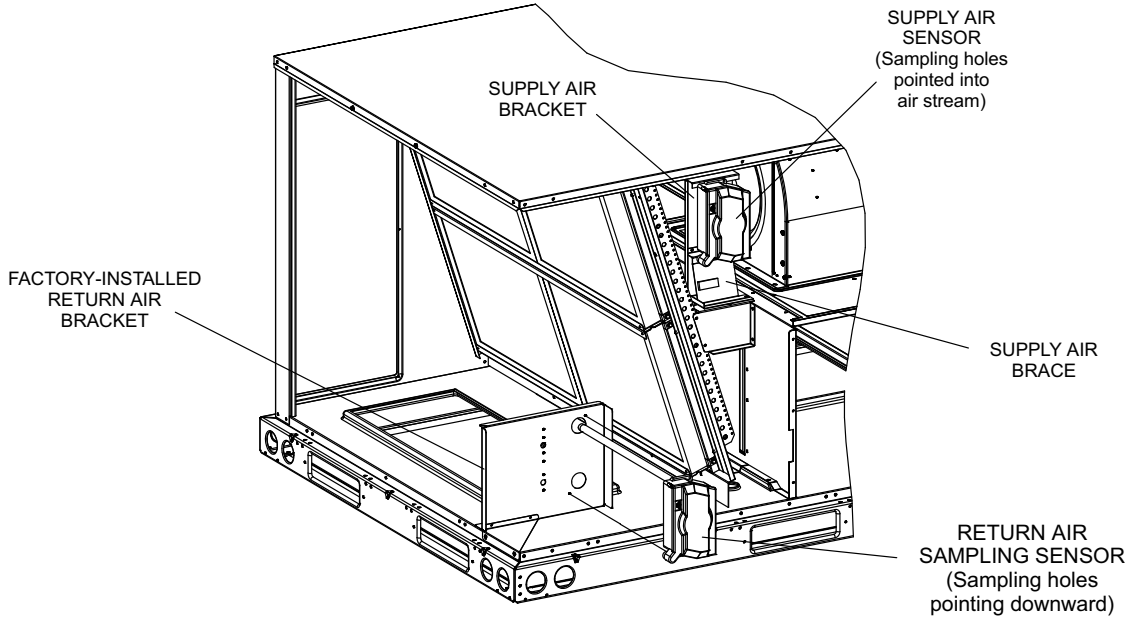

FIGURE 5

SMOKE DETECTOR SENSOR WITH SAMPLING TUBE AND EXHAUST TUBE

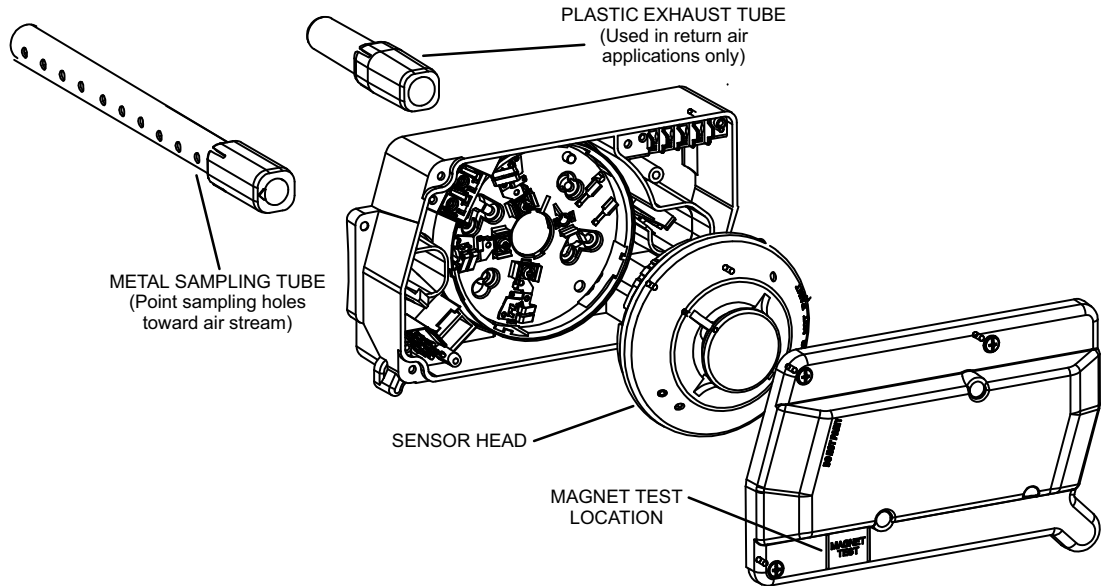

FIGURE 6

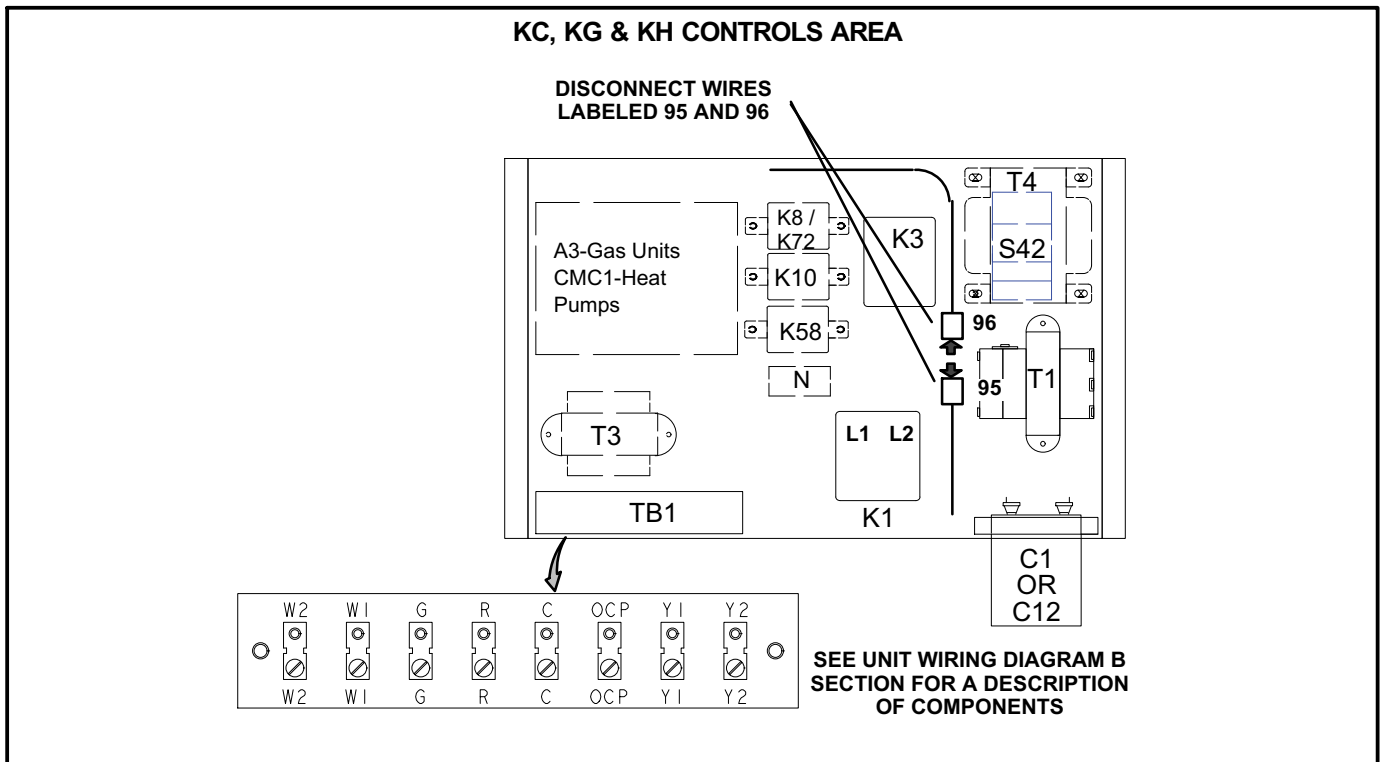

FIGURE 7

Wiring - KG/KC/KH Units

- 1 - Locate and disconnect wires labeled 95 and 96 in the control area above compressor. See figure 7.
- 2 - Connect wires labeled 95, 96 and TB1-C from the kit harness to wires labeled 95, 96 and TB1-C in unit.
- 3 - Route harness wires to the top of the unit. Secure to existing bundle of wires and route to control area above compressor. See figure 8. Make sure wires are secured away from other components.
- 4 - Make jack/plug connections as shown in figure 9 when installing return air smoke detector only, figure 10 when installing supply air smoke detector only, and figure 11 when installing both supply and return air smoke detectors. Refer to respective wiring diagrams in figure 12, 13 and 14.

NOTE - In single-sensor applications, the wiring harness is sized for return air applications. There will be excess wiring in supply air applications. Gather excess wire and secure away from other components.

WIRE ROUTING KG, KC & KH UNITS

Connect J255 and P250 harnesses to power board P255 and J250. On dual sensor applications, also connect P252 harness to power board J252.

ROUTE THROUGH FOAM INSULATION TUBE BETWEEN BLOWER AND COMPRESSOR SECTIONS

ROUTE THROUGH PLASTIC CONDUIT OVER FILTER FRAME

FILTER ACCESS PANEL

Connect P251 harness to RA sensor J251 **OR** SA sensor J253. On dual sensor applications, connect RA P251 harness to RA sensor J251 **AND** P253 harness to J253 SA sensor.

Note - Harness routing also applies to LGH/ LCH units in supply air only applications. Refer to "Wiring - LGH/LCH Units" section.

FIGURE 8

KC, KG or KH Unit Application with Single Return Air Smoke Detector
 (Note: Verify that power board DIP switch is set to 1)

Kit 53W78 three harnesses provided; discard jumper (shortest) harness.

Kit Harnesses -----

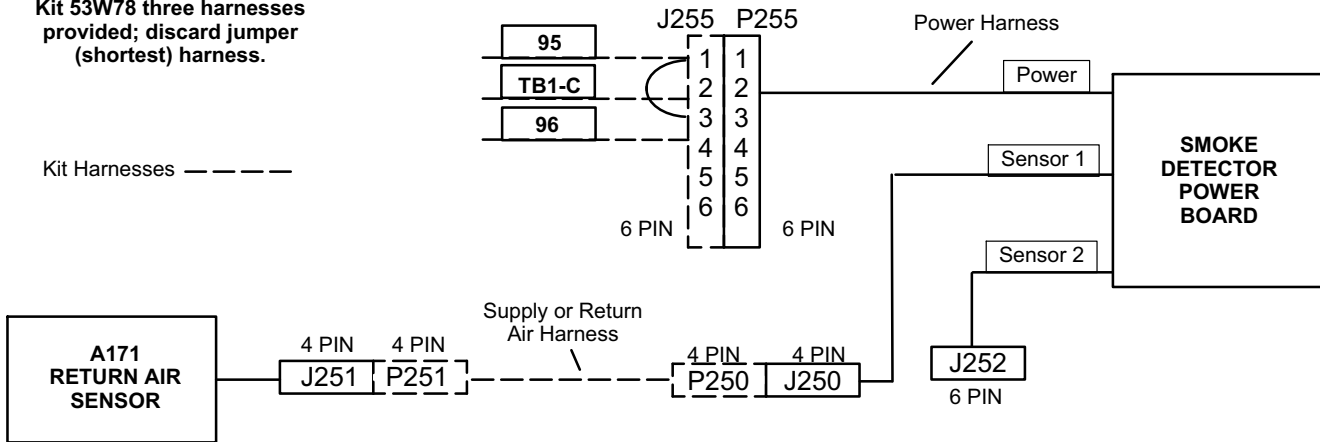

FIGURE 9

KC, KG or KH Unit Application with Single Supply Air Smoke Detector
 (Note: Verify that power board DIP switch is set to 1)

Kit 53W78 three harnesses provided; discard jumper harness.

Kit Harnesses -----

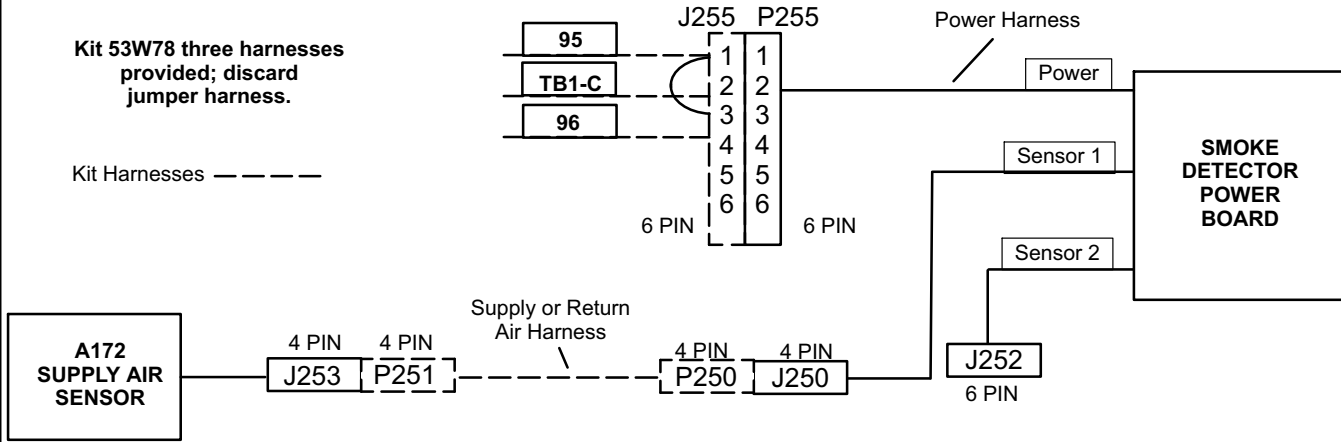

FIGURE 10

KC, KG or KH Unit Application with Return Air and Supply Air Smoke Detector
 (Note: Verify that power board DIP switch is set to 2)

Kit 53W79 two harnesses provided.

Kit Harnesses -----

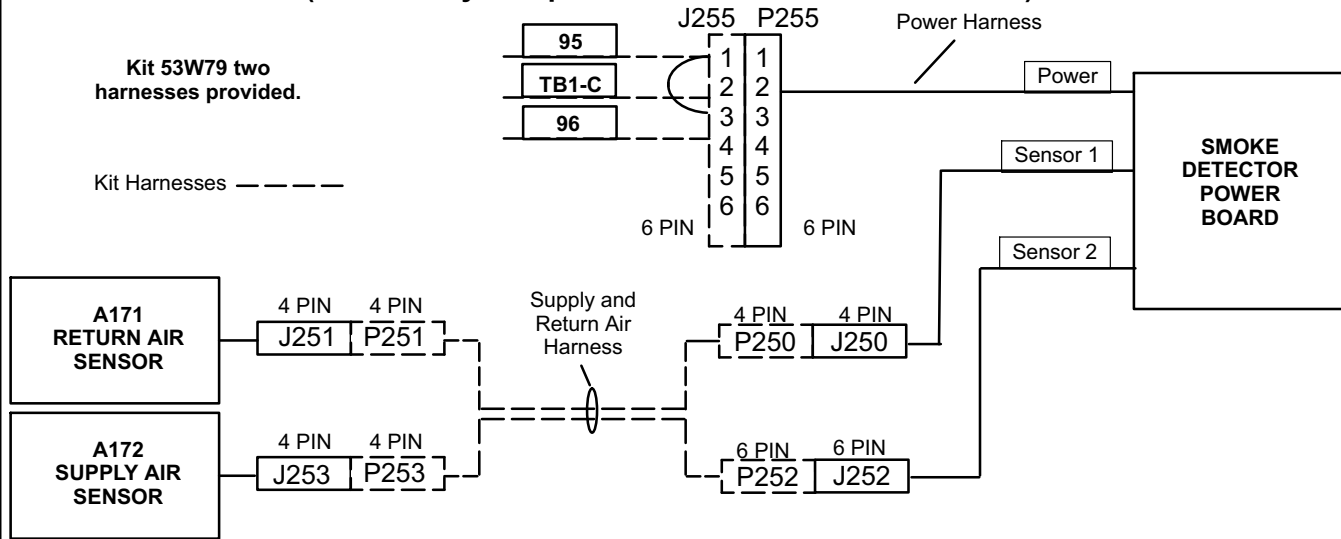
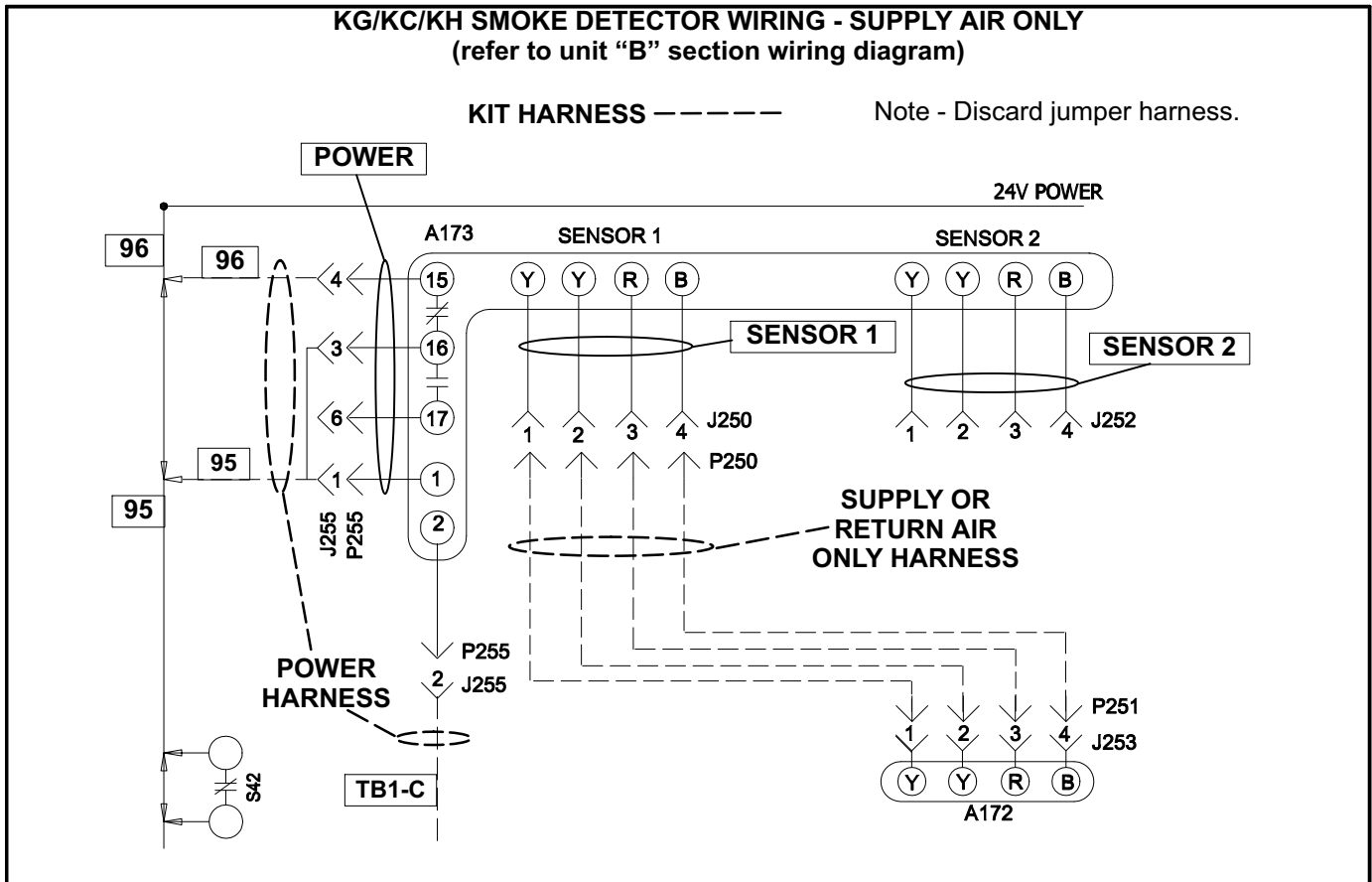
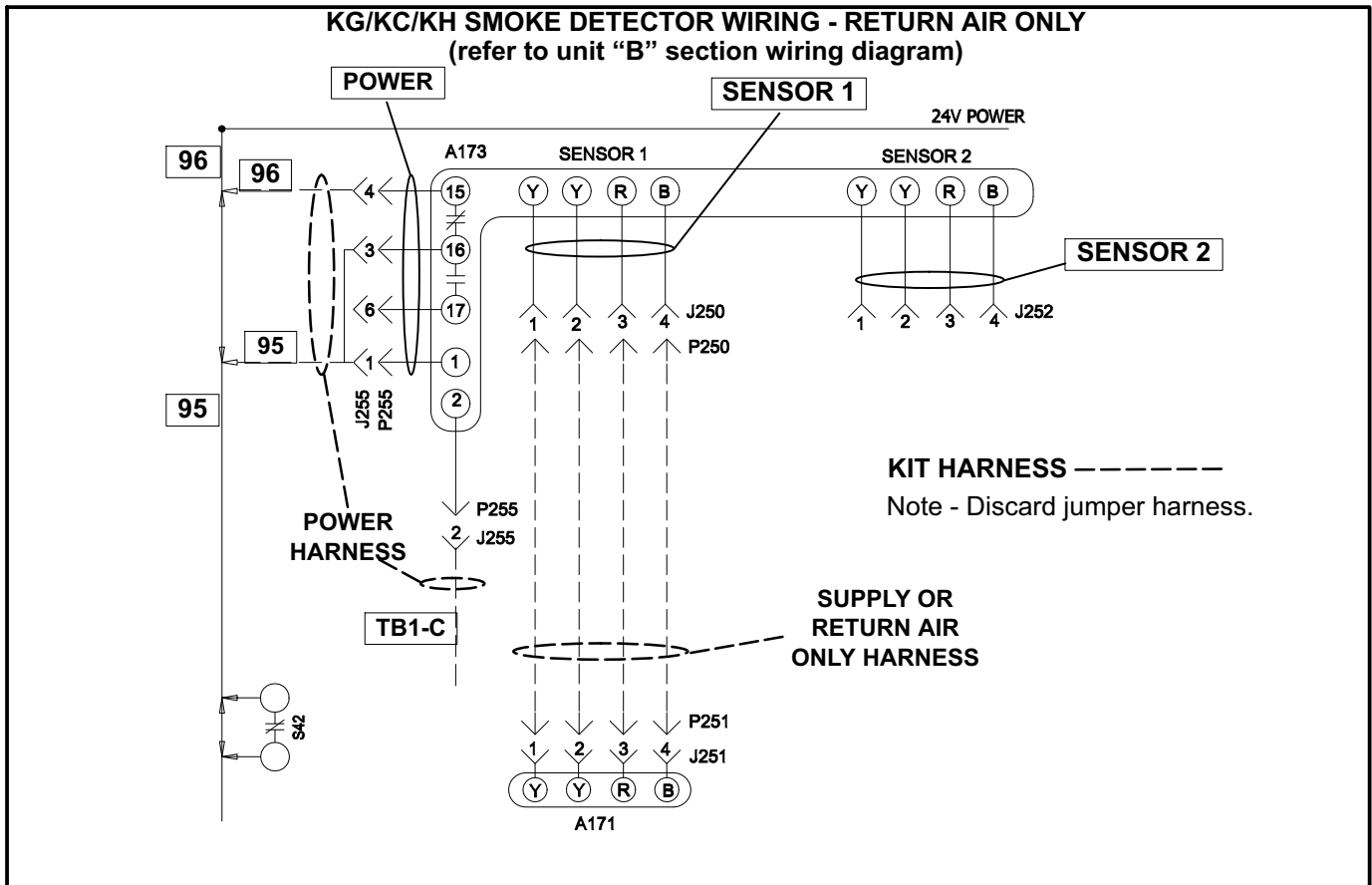

FIGURE 11



KG/KC/KH SMOKE DETECTOR WIRING - SUPPLY AND RETURN AIR
 (refer to unit "B" section wiring diagram)

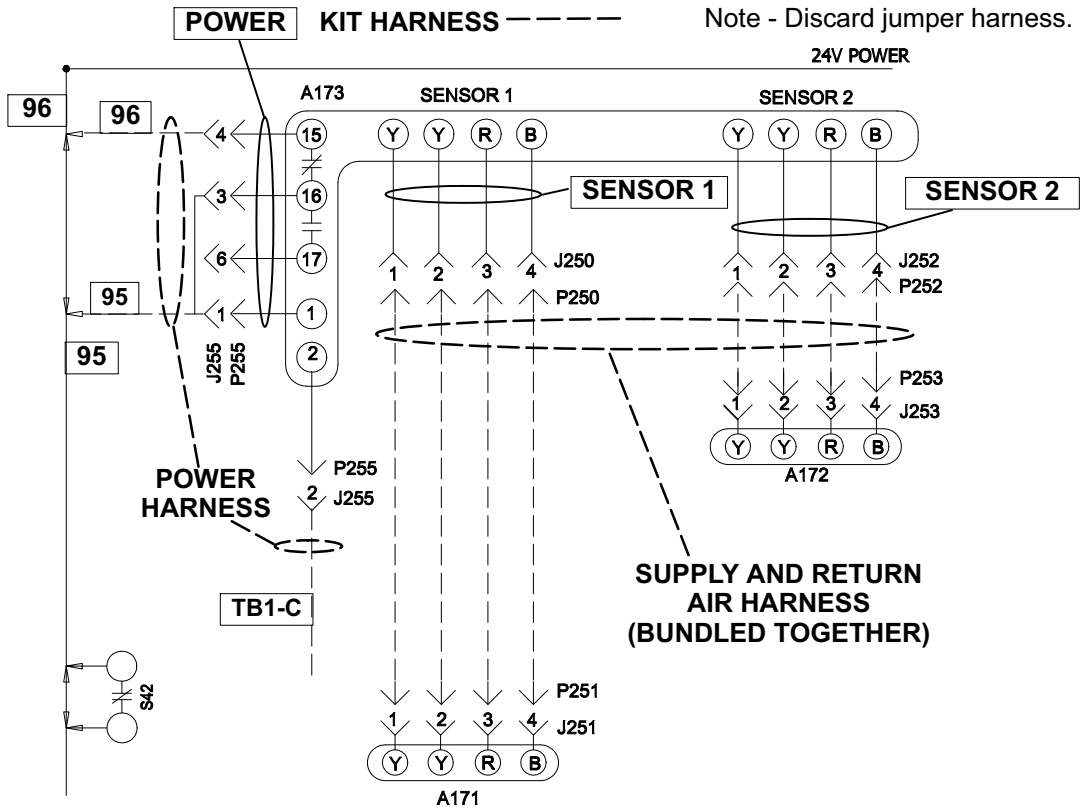
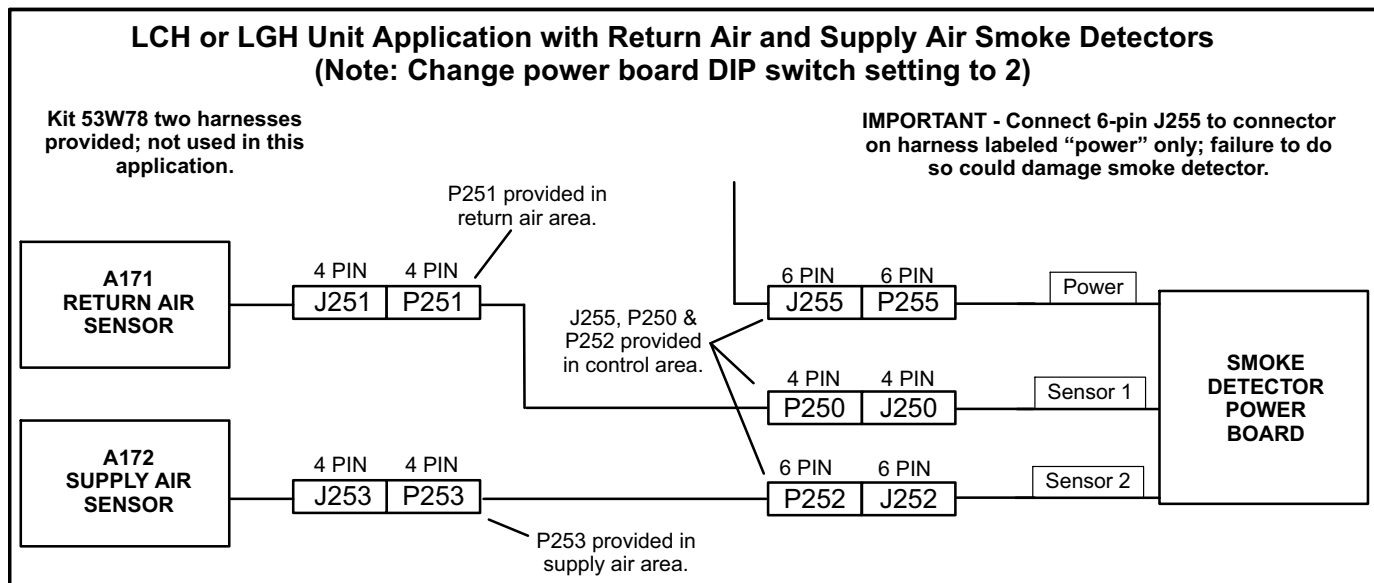
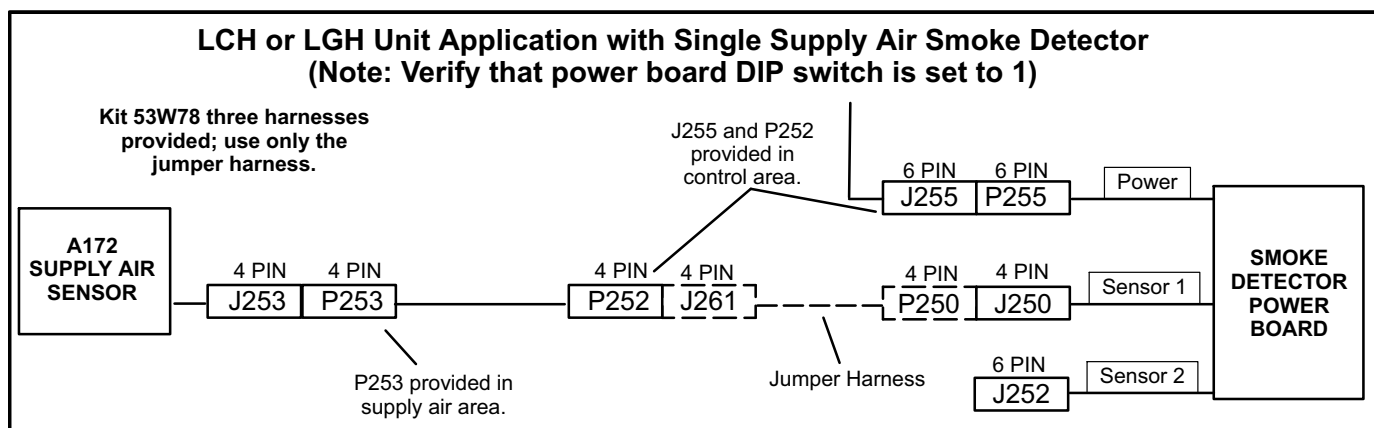
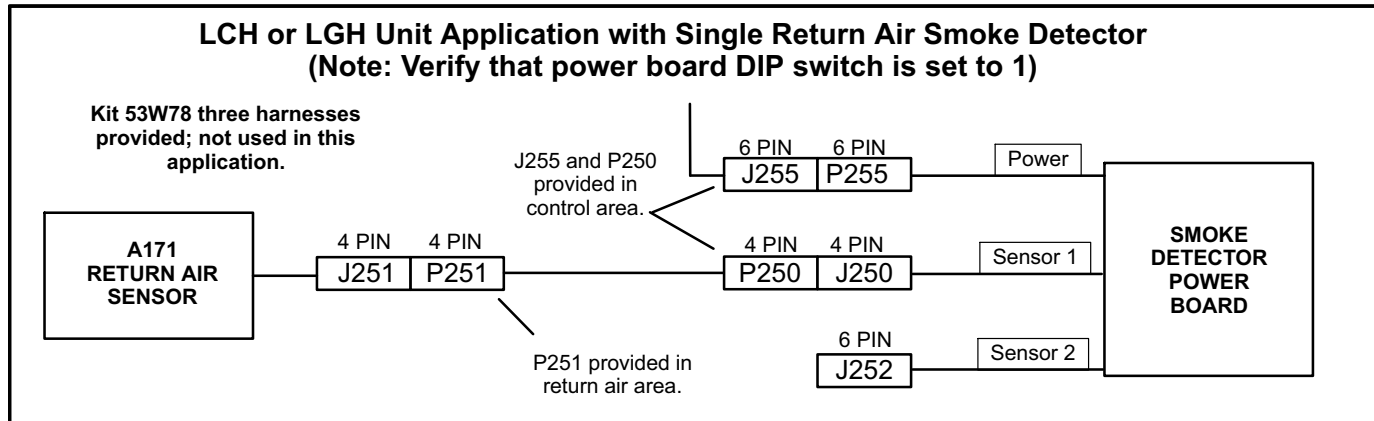

FIGURE 14

Wiring - LGH & LCH Units

Make jack/plug connections as shown in figure 15 when installing return air smoke detector only, figure 16 when installing supply air smoke detector only and figure 17 when installing both supply and return air smoke detectors. Refer to wiring diagrams in figure 18, 19 and 20.

The kit jumper harness is used in single supply air applications only. Route harness as shown in figure 8. Discard harnesses in other applications.



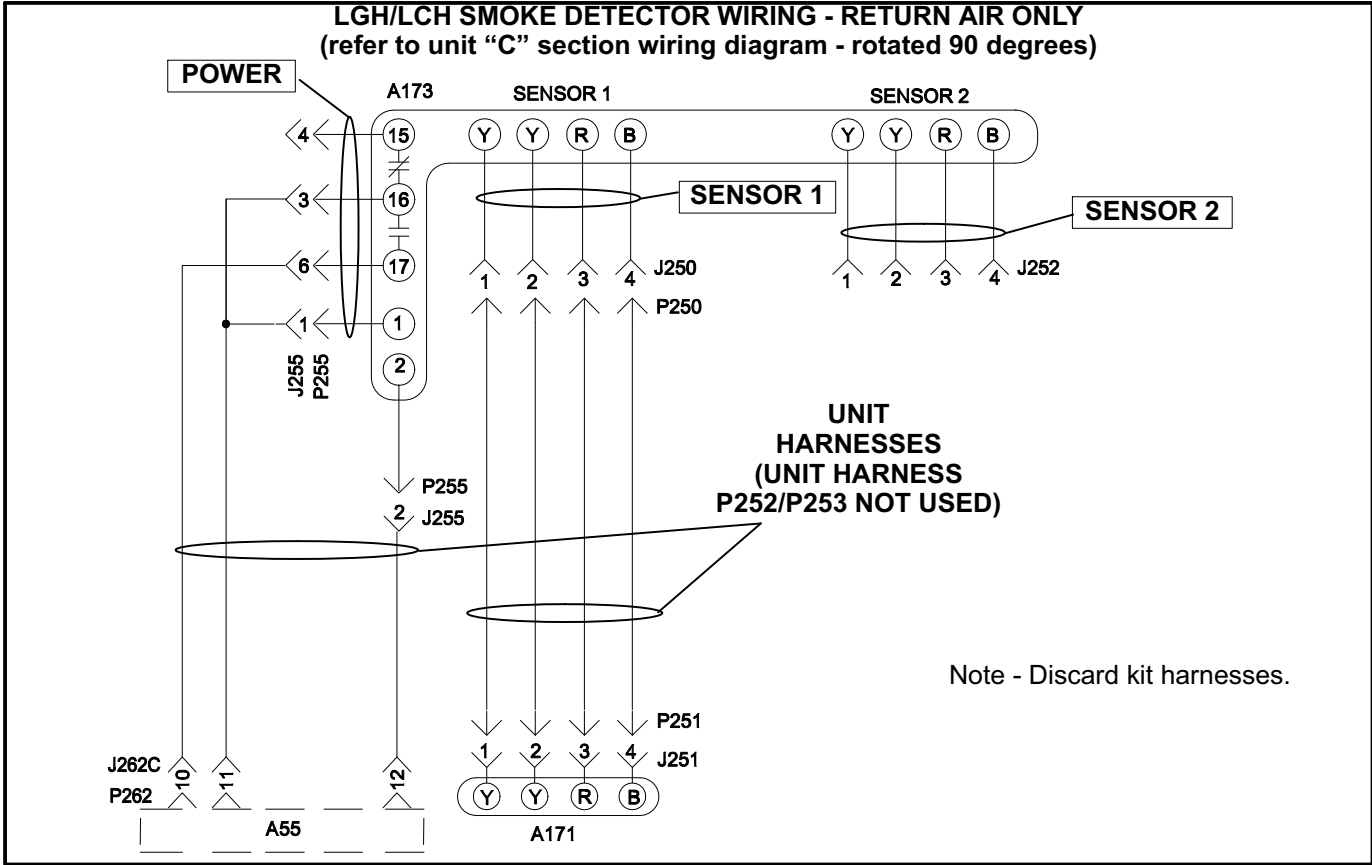

FIGURE 18

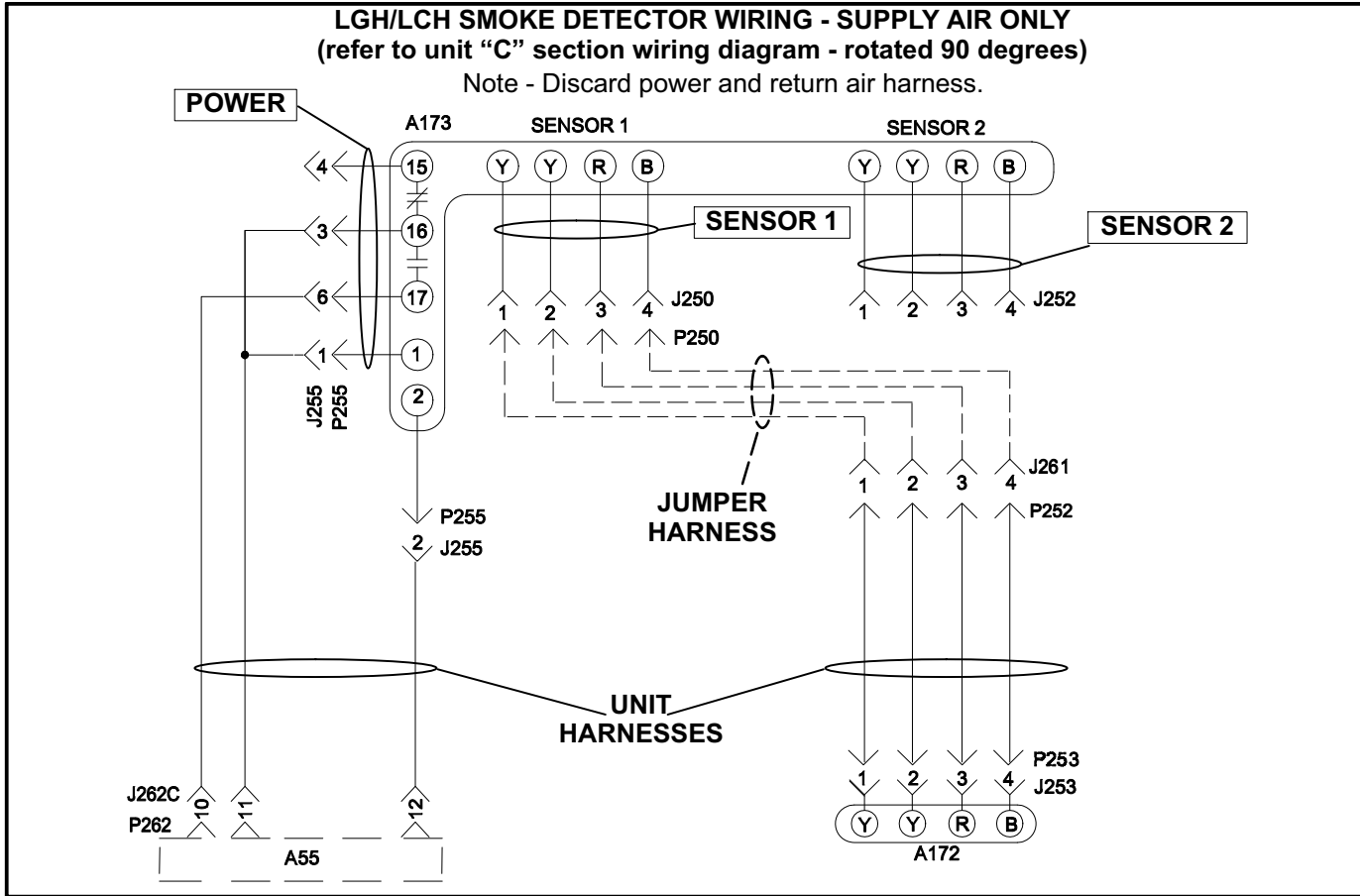

FIGURE 19

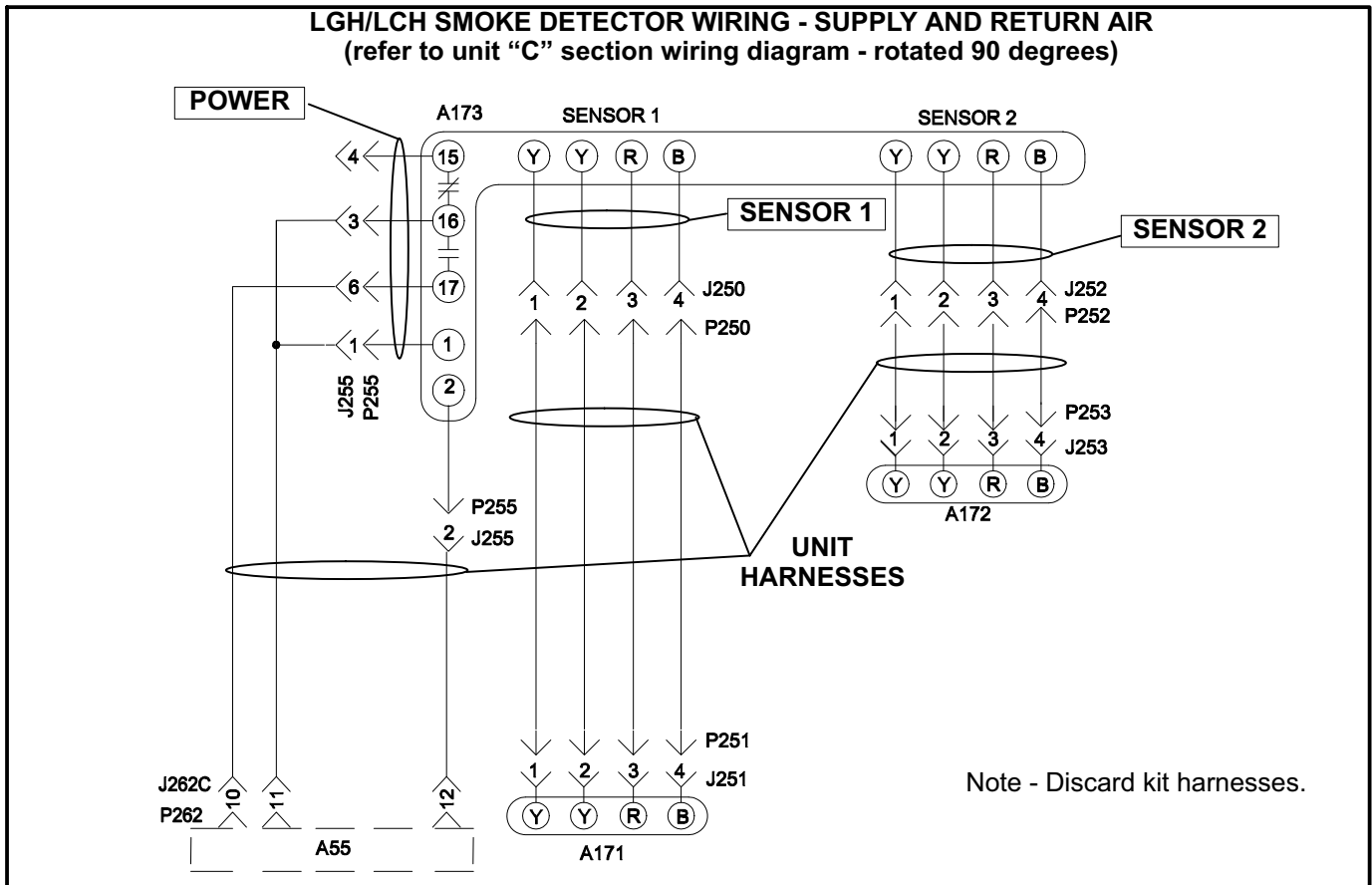

FIGURE 20

Test Magnet(s)

A test magnet is provided in a bag assembly with each sensor. Remove the magnet from the bag assembly and place it on a metal surface near the sensor. The magnet is used during test procedures.

Maintenance and Test Procedure Instructions

The sensor manufacturer's instructions, which are provided with each sensor, outline information on maintenance and test procedures. Place these instructions in the literature pouch for future reference.