

PRODUCT SPECIFICATIONS

Bulletin No. KHA-092-150 (3/2016)

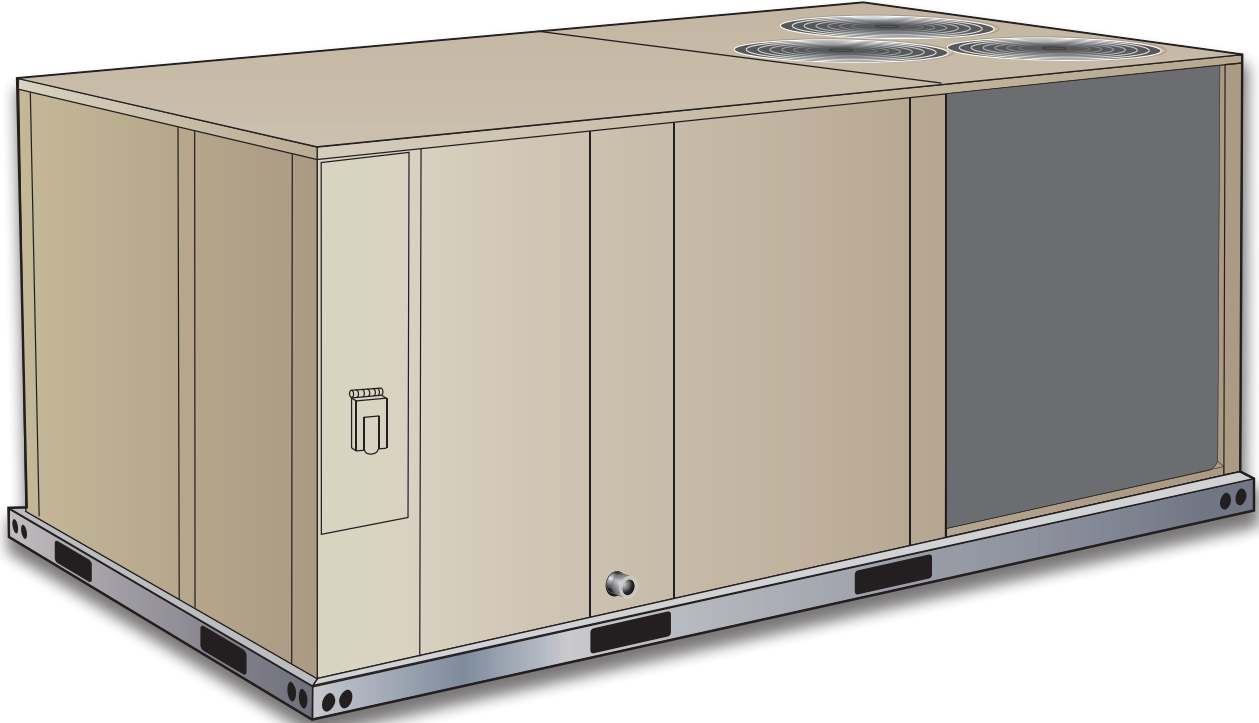

**ASHRAE 90.1
COMPLIANT**

7.5 to 12.5 Tons
Net Cooling Capacity – 87,000 to 138,000 Btuh
Net Heating Capacity - 89,000 to 138,000 Btuh
Optional Electric Heat - 7.5 to 60 kW

MODEL NUMBER IDENTIFICATION

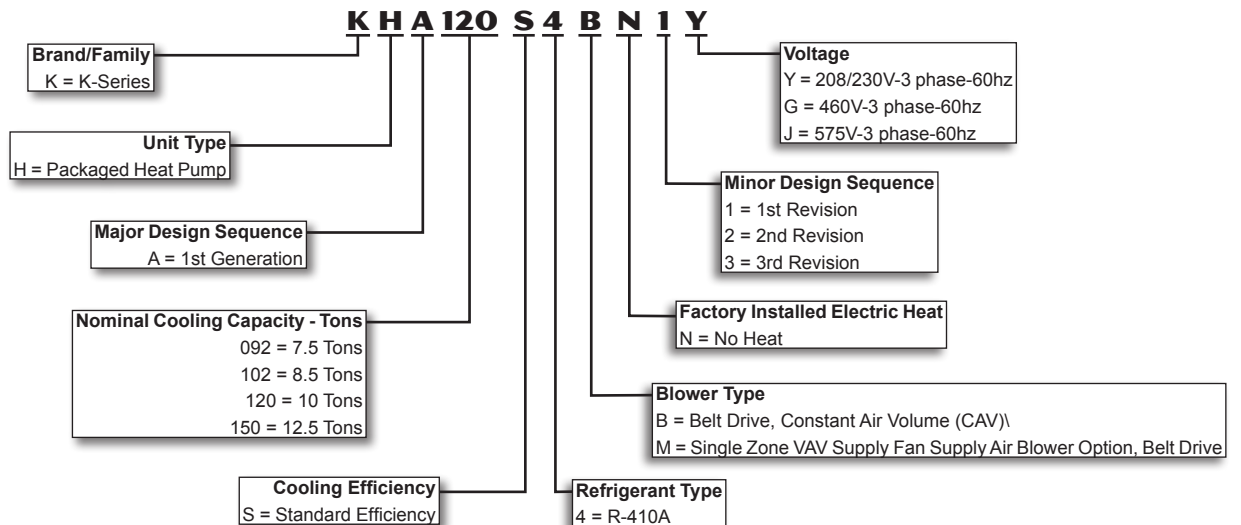

FEATURES AND BENEFITS

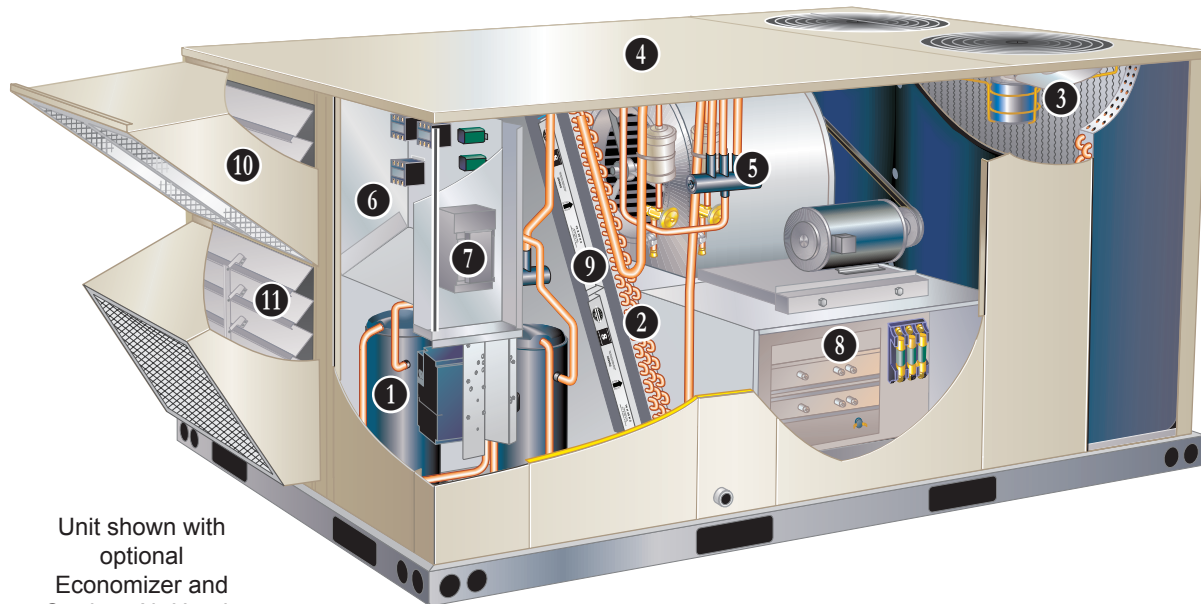

Unit shown with optional Economizer and Outdoor Air Hoods

K-Series™ rooftop units from Allied are the new standard for reliable, efficient rooftop units built for long-lasting performance that can significantly improve indoor environments. K-Series™ rooftop units feature:

- **R-410A Refrigerant** - Environmentally friendly.
- **Scroll Compressors** - Single speed scroll compressors are furnished on all models.
- **High Pressure Switches** - Protect compressor.
- **Isolated Compressor Compartment** - Allows performance check during normal compressor operation without disrupting airflow.
- **Independent Outdoor Fan Motor Mounts** - Allows for easy and efficient service access without removing the top panel.
- **Constant Air Volume (CAV) or Single Zone VAV Supply Fan Blower Option** - Allows constant or multi-staged air delivery.
- **Downflow or Horizontal Airflow** - Easy field conversion.
- **Two Fork Lift Slots on Three Sides** - Easy to pick up and transport units from almost any angle.
- **Corrosion-Resistant Removable, Reversible Drain Pan** - Provides application flexibility, durability and improved serviceability.
- **Thermostatic Expansion Valves** - Provide peak cooling performance across the entire application range.
- **MERV 8 or MERV 13 Filters** - Available as field installed option, provide an enhanced level of indoor air quality, and can help the building qualify for additional LEED credits.
- **Common Components** - Many maintenance items are standard throughout the entire product line, reducing the need to carry different parts to the job or maintain in inventory.

FEATURES AND BENEFITS

CONTENTS

Blower Data22
Dimensions - Accessories.35
Dimensions - Unit33
Electrical/Electric Heat Data26
Electric Heat Capacities.30
Features And Benefits	2
Model Number Identification	1
Options / Accessories	9
Outdoor Sound Data30
Ratings14
Specifications12
Unit Clearances.30
Weight Data32

APPROVALS

AHRI Certified to AHRI Standard 340/360-2007.

Units are ETL listed.

Units are CSA listed.

Components bonded for grounding to meet safety standards for servicing required by UL, ULC and National and Canadian Electrical Codes.

All models are ASHRAE 90.1-2010 energy efficiency compliant and meet or exceed requirements of Section 6.8.

Models equipped with the Single Zone VAV Supply Fan option meet California Code of Regulations, Title 24 and ASHRAE 90.1-2010 Section 6.4.3.10 requirements for staged airflow.

ISO 9001 Registered Manufacturing Quality System.

WARRANTY

Limited five years on compressors.

Limited five years Optional High Performance Economizers.

Limited one year all other covered components.

COOLING/HEATING SYSTEM

Designed to maximize sensible and latent cooling performance at design conditions.

System can operate in the cooling mode from 30°F to 125°F without any additional controls.

R-410A Refrigerant

Non-chlorine based, ozone friendly, R-410A.

1 Scroll Compressors

Scroll compressors on all models for high performance, reliability and quiet operation.

Resiliently mounted on rubber grommets for quiet operation.

Compressor Crankcase Heaters

Protects against refrigerant migration that can occur during low ambient operation.

Check/Thermal Expansion Valves

Assures optimal performance throughout the application range.

Removable element head.

Reversing Valves

4-way interchange reversing valve effects a rapid change in direction of refrigerant flow resulting in quick changeover from cooling to heating and vice versa.

Filter/Driers

High capacity filter/drier protects the system from dirt and moisture.

High Pressure Switches

Protects the compressor from overload conditions such as dirty condenser coils, blocked refrigerant flow, or loss of outdoor fan operation. Auto-reset.

Freezestats

Protects the evaporator coil from damaging ice build-up due to conditions such as low/no airflow, or low refrigerant charge.

2 Coil Construction

Copper tube construction, enhanced rippled-edge aluminum fins, flared shoulder tubing connections, silver soldered construction for improved heat transfer. Factory leak tested.

Indoor Coil

Cross row circuiting with rifled copper tubing optimizes both sensible and latent cooling capacity.

Condenser Coil

Two independent formed coils allow separation for cleaning.

Condensate Drain Pan

Plastic pan, sloped to meet drainage requirements of ASHRAE 62.1.

Side or bottom drain connections.

Reversible to allow connection at back of unit.

Outdoor Coil Fan Motors

Thermal overload protected, totally enclosed, permanently lubricated ball bearings, shaft up, wire basket mount.

3 Outdoor Coil Fans

PVC coated fan guard furnished.

FEATURES AND BENEFITS

COOLING/HEATING SYSTEM (continued)

Required Selections

Cooling Capacity

Specify nominal cooling capacity of the unit

Options/Accessories

Field Installed

Condensate Drain Trap

Available in copper or PVC.

Drain Pan Overflow Switch

Monitors condensate level in drain pan, shuts down unit if drain becomes clogged.

Low Ambient Kit

Cycles the outdoor fan while allowing compressor operation in the cooling cycle. This intermittent fan operation allows the system to operate without icing the evaporator coil and losing capacity. Designed for use in ambient temperatures no lower than 0°F.

CABINET

4 Construction

Heavy-gauge steel panels and full perimeter heavy-gauge galvanized steel base rail provides structural integrity for transportation, handling, and installation.

Base rails have rigging holes.

Three sides of the base rail have forklift slots.

Raised edges around duct and power entry openings in the bottom of the unit provide additional protection against water entering the building.

Airflow Choice

Units are shipped in downflow (vertical) configuration, can be field converted to horizontal airflow with optional Horizontal Discharge Kit.

Duct Flanges

Provided for horizontal duct attachment.

Power Entry

Electrical lines can be brought through the unit base or through horizontal access knock-outs

Exterior Panels

Constructed of heavy-gauge, galvanized steel with a two-layer enamel paint finish.

Insulation

All panels adjacent to conditioned air are fully insulated with non-hygroscopic fiberglass insulation.

Unit base is fully insulated in conditioned area. The insulation also serves as an air seal to the roof curb, eliminating the need to add a seal during installation.

Access Panels

Access panels are provided for the filter section, heating/blower section, and the compressor/controls section.

Options/Accessories

Factory Installed

Corrosion Protection

A completely flexible immersed coating with an electrodeposited dry film process. (AST ElectroFin E-Coat) Meets Mil Spec MIL-P-53084, ASTM B117 Standard Method Salt Spray Testing.

Indoor Corrosion Protection:

- Coated coil
- Painted blower housing
- Painted base

Outdoor Corrosion Protection:

- Coated coil
- Painted base

Hinged Access Panels

Large access panels are hinged and have quarter-turn latches for quick and easy access to maintenance areas (filter, compressor / controls, heating / blower).

Field Installed

Combination Coil/Hail Guards

Heavy gauge steel frame painted to match cabinet with expanded metal mesh to protect the outdoor coil from damage.

Horizontal Discharge Kit

Consists of duct covers to block off downflow supply and return air openings for horizontal applications.

Also includes return air duct flanges for end return air when economizer is used in horizontal applications.

NOTE - When configuring unit for horizontal application with economizer, a separate Horizontal Barometric Relief Damper with Hood must be ordered separately for installation in the return air duct.

Return Air Adaptor Plate

For same size LC/LG/LH and TC/TG/TH unit replacement.

Installs on return air opening in unit to match return air opening on existing roof curbs. Also see Accessory Air Resistance table.

5 BLOWER

A wide selection of supply air blower options are available to meet a variety of airflow requirements.

Motor

Overload protected, equipped with ball bearings. Belt drive motors are offered on all models and are available in several different sizes to maximize air performance.

Supply Air Blower

Forward curved blades, double inlet, blower wheel is statically and dynamically balanced. Equipped with ball bearings and adjustable pulley (allows speed change).

Blower assembly slides out of unit for servicing.

Required Selections

Select Constant Air Volume (CAV) or Single Zone VAV Supply Fan Supply Air Blower Option

Order blower motor horsepower and drive kit number required when base unit is ordered, see Drive Kit Specifications Table.

CAV Operation

On units ordered with the Constant Air volume (CAV) option, the supply air blower will provide a constant volume of air.

FEATURES AND BENEFITS

BLOWER (continued)

Single Zone VAV Supply Fan Operation

Units ordered with the Single Zone VAV Supply Fan option utilize a Variable Frequency Drive (VFD) to stage the supply air blower airflow. The VFD alters the frequency and voltage of the power supply to the blower to control blower speed.

The supply air blower has two speeds:

1. Low speed for part-load cooling operation. Note - Low speed is 66% of high speed.
2. High speed for full load cooling and all heat modes.

Full speed blower operation is set by adjusting the motor pulley to deliver the desired air volume.

The ventilation speed is selectable between high and low speed.

*NOTE - Part load airflow in cooling mode on **Single Zone VAV Supply Fan** units should not be set below 220 cfm/nominal full load ton to reduce the risk of evaporator coil freeze-up.*

The VFD has an operational range of -40 to 125° F outdoor air ambient temperature.

Lower operating costs are obtained when the blower is operated on lower speeds.

Single Zone VAV Supply Fan Sequence of Operation

Ventilation speed is determined by the VENT SPEED switch setting on VFD control board (LO or HI).

Blower operates in low speed for mechanical cooling (Y1).

Blower operates in high speed for any other mode (free cooling, mechanical cooling Y1+Y2, and heating).

Economizer damper minimum position is fully closed in unoccupied mode.

In occupied mode, the economizer damper minimum position is determined by the setting of the two potentiometers on VFD control board.

- LO SPD MIN POS potentiometer sets the minimum position when blower is operating at low speed.
- HI SPD MIN POS potentiometer sets the minimum position when blower is operating at high speed.

Options/Accessories

Field Installed

VFD Manual Bypass Kit

VFD Manual Bypass Control is available as a kit for units equipped with the Single Zone VAV Supply Fan option.

The VFD Manual Bypass Control is a manual bypass and is set by re-configuring the wiring on the unit.

CONTROLS

6 Unit Control

All control voltage is provided via a 24V (secondary) transformer with built-in circuit breaker protection.

Heat/Cool Staging - Capable of up to 2 heat / 2 cool staging with a third party DDC control system or thermostat.

Low Voltage Terminal Block -

Provides screw terminal connections for thermostat or controller wiring.

Night Setback Mode - Saves energy by closing outdoor air dampers and operating supply fan on thermostat demand only.

Defrost Control

Provides a defrost cycle, if needed, every 30 or 60 or 90 minutes (adjustable) of compressor on" time at outdoor coil temperature below 35°F. Temperature switch mounted on outdoor coil liquid line terminates defrost cycle.

Options/Accessories

Field Installed

Smoke Detector

Photoelectric type, installed in supply air section, return air section or both sections. Available with power board and single sensor (supply or return) or power board and two sensors (supply and return).

FEATURES AND BENEFITS

ELECTRICAL

Marked & Color-Coded Wiring

All electrical wiring is color-coded and marked to identify which components it is connecting.

Electrical Plugs

Positive connection electrical plugs are used to connect common accessories or maintenance parts for easy removal or installation.

Phase Monitor

(Factory Installed on Units Equipped with the Single Zone VAV Supply Fan)

Phase monitor located in the control compartment detects the phasing of incoming power. If the incoming power is out of phase or if any of the three phases are lost, an indicator LED on the phase monitor will turn red and the unit will not start. In normal operation with correct incoming power phasing, the LED will be green.

Required Selections

Voltage Choice

Specify when ordering base unit.

Options/Accessories

Factory or Field Installed

7 Disconnect Switch

Accessible from outside of unit, spring loaded weatherproof cover furnished. Main power to the unit is field connected to the disconnect which allows all power to be shut off for service. See Electrical/ Electric Heat tables for ordering information, page 29.

GFI Service Outlets (2)

115V ground fault circuit interrupter (GFCI) type, non-powered, field-wired.

Field Installed

8 Electric Heat

Helix wound nichrome elements, individual element limit controls, wiring harness. Unit fuse block is furnished as standard. See Options / Accessories tables for ordering information.

GFI Weatherproof Cover

Single-gang cover.

Heavy-duty UV-resistant polycarbonate case construction.

Hinged base cover with gasket.

INDOOR AIR QUALITY

9 Air Filters

Disposable 2-inch filters furnished as standard.

Options/Accessories

Field Installed

High Efficiency Air Filter

Disposable MERV 8 or MERV 13 (Minimum Efficiency Reporting Value based on ASHRAE 52.2) efficiency 2-inch pleated filters.

Replacement Filter Media Kit With Frame

Replaces existing pleated filter media. Includes washable metal mesh screen and metal frame with clip for holding replaceable non-pleated filter.

UVC Germicidal Lamps

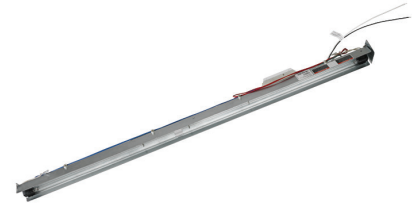

Germicidal lamps emit ultra-violet (UV-C) energy, which has been proven to be effective in reducing microbes such as viruses, bacteria, yeasts, and molds. This process either destroys the organism or controls its ability to reproduce.

UV-C energy greatly reduces the growth and proliferation of mold and other bioaerosols (bacteria and viruses) on illuminated surfaces (particularly coil and drain pan).

Lamps are field installed in the blower/evaporator coil section.

All necessary hardware for installation is included.

Lamps operate on 208/230V power supply. Step-down transformer must be field supplied when used with 460V and 575V rooftop units.

Magnetic safety interlock terminates power when access panels are removed.

Approved by ETL.

Indoor Air Quality (CO₂) Sensors

Monitors CO₂ levels, reports to the Unit Controller which adjusts economizer dampers as needed.

ECONOMIZER OPTIONS

Factory or Field Installed

10 Economizer Features (Standard and High Performance Common Features)

Downflow or Horizontal with Outdoor Air Hood and Barometric Relief Dampers with Exhaust Hood.

11 Barometric Relief Dampers allow relief of excess air, aluminum blade dampers prevent blow back and outdoor air infiltration during off cycle, bird screen furnished.

NOTE - Optional Horizontal Low Profile Barometric Relief Dampers with Exhaust Hood are available for field installation in a reduced space.

Occupied/Unoccupied mode with field furnished setback thermostat.

Demand Control Ventilation (DCV) ready using optional CO₂ sensors.

Mixed Air Sensor is furnished for field installation in the rooftop unit. Sensor is factory installed when Economizers are factory installed.

Single sensible sensor is furnished with Economizer and enables economizer operation if the outdoor temperature is less than the setpoint of the control.

Standard Economizer Features (Not for Title 24)

Gear-driven action, return air and outdoor air dampers, plug-in connections to unit, nylon bearings, neoprene seals, 24-volt, fully-modulating spring return motor.

Standard Economizer Control Module

The Standard Economizer Control Module can be adjusted to operate based on outdoor air temperatures.



Economizer Controls:

- Damper Minimum Position - Can be set lower than traditional minimum air requirements resulting in cost savings.
- IAQ Sensor - Signals dampers to modulate and maintain 55°F when CO₂ is higher than the CO₂ setpoint.
- Demand Control Ventilation (DCV) LED - A steady green Demand Control Ventilation LED indicates the IAQ reading is higher than setpoint and requires more fresh air.
- Free Cool LED - A steady green LED indicates outdoor air is suitable for free cooling.

Free Cooling runs when outdoor air temperature is lower than the set temperature on the economizer control.

NOTE: The Free Cooling default setting for outdoor air temperature sensor is 55°F.

High Performance Economizer Features

Approved for California Title 24 building standards.

ASHRAE 90.1-2010 compliant.

Gear-driven action, high torque 24-volt fully-modulating spring return damper motor, return air and outdoor air dampers, plug-in connections to unit, stainless steel bearings, enhanced neoprene blade edge seals and flexible stainless steel jamb seals to minimize air leakage.

NOTE - High Performance Economizers are not approved for use with enthalpy controls in Title 24 applications.

High Performance Economizer Control Module

Module provides inputs and outputs to control economizer based on



parameter settings. Module automatically detects sensors by polling to determine which sensors are installed in system.

Module displays any alarm

messages (fault detection and diagnostics) as an aid in troubleshooting.

Non-volatile memory retains parameter settings in case of power failure.

Keypad with four navigation buttons and LCD screen is furnished for setting economizer parameters.

- Menu Up/Exit (↑) button returns to the main menu.
- Arrow Up (▲) button moves to the previous or next parameter within the selected menu.
- Arrow Down (▼) button moves to the next parameter within the selected menu.
- Select (enter) (↵) button confirms parameter selection.

Main Menu Structure:

- STATUS (economizer and system operation status)
- SETPOINTS (settings for various setpoint parameters)
- SYSTEM SETUP (settings/information about the system)
- ADVANCED SETUP (freeze protection, CO₂ settings, stage 3 delay and additional calibration settings)
- CHECKOUT (damper positions)
- ALARMS (output signal that can be configured for remote alarm monitoring)

NOTE - The Free Cooling setpoint for Title 24 applications must be set based on the Climate Zone where the system is installed. See Section 140.4 "Prescriptive Requirements for Space Conditioning Systems" of the California Energy Commission's 2013 Building Energy Efficiency Standards.

Refer to Installation Instructions for complete setup information and menu parameters available.

ECONOMIZER OPTIONS

continued

Factory or Field Installed

Single Enthalpy Temperature Control

(Not for Title 24)

Outdoor air enthalpy sensor enables economizer if the outdoor enthalpy is less than the setpoint of the control. Single enthalpy control is furnished with economizer.

Field Installed

Differential Enthalpy Control (Not for Title 24)

Order two Single Enthalpy Control Kits. One is field installed in the return air section, the other in the outdoor air section. Allows the economizer control board to select between outdoor air or return air, whichever has lower enthalpy.

EXHAUST OPTIONS

Field Installed

Horizontal Low Profile Barometric Relief Dampers

Replaces barometric relief dampers furnished with Economizer.

For use when unit is configured for horizontal applications in a reduced space requiring an economizer.

Allows relief of excess air.

Aluminum blade dampers prevent blow back and outdoor air infiltration during off cycle.

Field installed in return air duct.

Exhaust hood with bird screen furnished.

Requires Horizontal Discharge Kit.

Power Exhaust Fan

Installs internal to unit for downflow applications only with economizer option. Provides exhaust air pressure relief. Interlocked to run when supply air blower is operating, fan runs when outdoor air dampers are 50% open (adjustable), motor is overload protected. Requires Economizer with Outdoor Air Hood and Barometric Relief Dampers. Fan is 20 in. diameter with 5 blades (K1PWRE10B) WITH 1/3 hp motor.

OUTDOOR AIR OPTIONS

Factory or Field Installed

Outdoor Air Damper - Downflow or Horizontal With Air Hood

Linked mechanical dampers, 0 to 25% (fixed) outdoor air adjustable, installs in unit. Includes outdoor air hood.

Automatic model features fully modulating spring return damper motor with plug-in connection.

Manual model features a slide damper.

Maximum mixed air temperature in cooling mode: 100°F.

ROOF CURBS

Nailer strip furnished, mates to unit, U.S. National Roofing Contractors Approved, shipped knocked down.

Hybrid Roof Curbs, Downflow

Roof curb can be assembled using interlocking tabs to fasten corners together. No tools required.

Curb can also be fastened together with furnished hardware.

Available in 8, 14, 18, and 24 inch heights.

Adjustable Pitch Curb

Fully adjustable pitch curbs (3/4 in. per foot in any direction) provide a level platform for rooftop units allowing flexible installations on roofs with uneven or sloped angles.

Uses interlocking tabs to fasten corners together. No tools required.

Hardware is furnished to connect upper curb with lower curb.

Available in 14 inch height.

Adaptor Curbs (not shown)

Curbs are regionally sourced. Dimensions will vary based upon the source. Contact your local sales representative for a detailed cut sheet with applicable dimensions.

CEILING DIFFUSERS

Ceiling Diffusers

(Flush or Step-Down)

Aluminum grilles, large center grille, insulated diffuser box with flanges, hanging rings furnished, interior transition (even air flow), internally sealed (prevents recirculation), adapts to T-bar ceiling grids or plaster ceilings.

Transitions (Supply and Return)

Used with diffusers, installs in roof curb, galvanized steel construction, flanges furnished for duct connection to diffusers, fully insulated.

OPTIONS / ACCESSORIES

Item Description	Model Number	Catalog Number	Unit Model No			
			092	102	120	150
COOLING SYSTEM						
Condensate Drain Trap	PVC - C1TRAP20AD2	76W26	X	X	X	X
	Copper - C1TRAP10AD2	76W27	X	X	X	X
Corrosion Protection		Factory	O	O	O	O
Drain Pan Overflow Switch	K1SNSR71AB1-	74W42	X	X	X	X
Efficiency		Standard	O	O	O	O
Low Ambient Kit	K1SNSR33B-1	54W16	X	X	X	X
Refrigerant Type		R-410A	O	O	O	O
BLOWER - SUPPLY AIR						
Blower Option	CAV (Constant Air Volume)	Factory	O	O	O	O
	Single Zone VAV Supply Fan	Factory	O	O	O	O
Blower Motors	Belt Drive - 2 hp	Factory	O	O	O	O
	Belt Drive - 3 hp	Factory	O	O	O	O
	Belt Drive - 5 hp	Factory	O	O	O	O
VFD Manual Bypass Kit (for Single Zone VAV Supply Fan equipped units only)	KVFDB12C-1	90W53	X	X	X	X
Drive Kits See Blower Data Tables for selection	Kit #1 590-890 rpm	Factory	O	O	O	O
	Kit #2 800-1105 rpm	Factory	O	O	O	O
	Kit #3 795-1195 rpm	Factory	O	O	O	O
	Kit #4 730-970 rpm	Factory	O	O	O	O
	Kit #5 940-1200 rpm	Factory	O	O	O	O
	Kit #6 1015-1300 rpm	Factory	O	O	O	O
	Kit #10 900-1135 rpm	Factory	O	O	O	O
	Kit #11 1040-1315 rpm	Factory	O	O	O	O
	Kit #12 1125-1425 rpm	Factory	O	O	O	O
CABINET						
Combination Coil/Hail Guards	K1GARD51BS1	13T24	X	X	X	
	K1GARD51BP1	13T25				X
Hinged Access Panels		Factory	O	O	O	O
Horizontal Discharge Kit	K1HECK00B-1	51W25	X	X	X	X
Return Air Adaptor Plate (for LC/LG/LH and TC/TG/TH unit replacement)	C1CONV10B-1	54W96	X	X	X	X
CONTROLS						
Commercial Controls						
BACnet®	K0CTRL31B-1	96W15	OX	OX	OX	OX
BACnet® Thermostat with Display	K0SNSR01FF1	97W23	X	X	X	X
BACnet® Thermostat without Display	K0SNSR00FF1	97W24	X	X	X	X
Novar® 2051	K0CTRL30B-1	96W12	OX	OX	OX	OX
Plenum Cable (75 ft.)	K0MISC00FF1	97W25	X	X	X	X
Smoke Detector - Supply or Return (Power board and one sensor)	C1SNSR44B-2	11K76	X	X	X	X
Smoke Detector - Supply and Return (Power board and two sensors)	C1SNSR43B-2	11K80	X	X	X	X

NOTE - Catalog and model numbers shown are for ordering field installed accessories.

OX - Configure To Order (Factory Installed) or Field Installed

O = Configure To Order (Factory Installed)

X = Field Installed

OPTIONS / ACCESSORIES

Item Description	Model Number	Catalog Number	Unit Model No			
			092	102	120	150
INDOOR AIR QUALITY						
Air Filters						
High Efficiency Air Filters	MERV 8 - C1FLTR15B-1	50W61	X	X	X	X
20 x 25 x 2 (Order 4 per unit)	MERV 13 - C1FLTR40B-1	52W41	X	X	X	X
Replacement Media Filter With Metal Mesh Frame (includes non-pleated filter media)	C1FLTR30B-1-	Y3063	X	X	X	X
Indoor Air Quality (CO₂) Sensors						
Sensor - Wall-mount, off-white plastic cover with LCD display	C0SNSR50AE1L	77N39	X	X	X	X
Sensor - Wall-mount, off-white plastic cover, no display	C0SNSR52AE1L	87N53	X	X	X	X
Sensor - Black plastic case with LCD display, rated for plenum mounting	C0SNSR51AE1L	87N52	X	X	X	X
Sensor - Wall-mount, black plastic case, no display, rated for plenum mounting	C0MISC19AE1	87N54	X	X	X	X
CO ₂ Sensor Duct Mounting Kit - for downflow applications	C0MISC19AE1-	85L43	X	X	X	X
Aspiration Box - for duct mounting non-plenum rated CO ₂ sensors (87N53 or 77N39)	C0MISC16AE1-	90N43	X	X	X	X
UVC Germicidal Lamps						
¹ UVC Light Kit (208/230v-1ph)	C1UVCL10B-1	54W62	X	X	X	X
ELECTRICAL						
Voltage 60 hz	208/230V - 3 phase	Factory	O	O	O	O
	460V - 3 phase	Factory	O	O	O	O
	575V - 3 phase	Factory	O	O	O	O
Disconnect Switch - See Electrical/Electric Heat tables for selection	80 amp - C1DISC080B-1	54W56	OX	OX	OX	OX
	150 amp - C1DISC150B-1	54W57	OX	OX	OX	OX
GFI Service Outlets	15 amp non-powered, field-wired (208/230V, 460V only) LTAGFIK10/15	74M70	OX	OX	OX	OX
	20 amp non-powered, field-wired (575V only) C1GFCI20FF1	67E01	X	X	X	X
Weatherproof Cover for GFI	C1GFCI99FF1	10C89	X	X	X	X
ELECTRIC HEAT						
7.5 kW	208/230V-3ph - C1EH0075B-1Y	56W38	OX	OX		
	460V-3ph - C1EH0075B-1G	56W39	OX	OX		
	575V-3ph - C1EH0075B-1J	56W40	OX	OX		
15 kW	208/230V-3ph - C1EH0015B-1Y	56W41	OX	OX	OX	OX
	460V-3ph - C1EH0150B-1G	56W42	OX	OX	OX	OX
	575V-3ph - C1EH0150B-1J	56W43	OX	OX	OX	OX
22.5 kW	208/230V-3ph - C1EH0225B-1Y	56W44	OX	OX	OX	OX
	460V-3ph - C1EH0225B-1G	56W45	OX	OX	OX	OX
	575V-3ph - C1EH0225B-1J	56W46	OX	OX	OX	OX
30 kW	208/230V-3ph - C1EH0300B-1Y	56W47	OX	OX	OX	OX
	460V-3ph - C1EH0300B-1G	56W48	OX	OX	OX	OX
	575V-3ph - C1EH0300B-1J	56W49	OX	OX	OX	OX
45 kW	208/230V-3ph - C1EH0450B-1Y	56W50	OX	OX	OX	OX
	460V-3ph - C1EH0450B-1G	56W51	OX	OX	OX	OX
	575V-3ph - C1EH0450B-1J	56W52	OX	OX	OX	OX
60 kW	208/230V-3ph - C1EH0600B-1Y	55W02			OX	OX
	460V-3ph - C1EH0600B-1G	55W03			OX	OX
	575V-3ph - C1EH0600B-1J	55W04			OX	OX

¹ Lamps operate on 110-230V single-phase power supply. Step-down transformer may be ordered separately for 460V and 575V units. Alternately, 110V power supply may be used to directly power the UVC ballast(s).

NOTE - Catalog and model numbers shown are for ordering field installed accessories.

OX - Configure To Order (Factory Installed) or Field Installed

O = Configure To Order (Factory Installed)

X = Field Installed

OPTIONS / ACCESSORIES

Item Description	Model Number	Catalog Number	Unit Model No			
			092	102	120	150
ECONOMIZER						
Standard Economizer (Not for Title 24)						
Standard Economizer with Single Temperature Control Downflow or Horizontal Applications - Includes Barometric Relief Dampers and Air Hoods	K1ECON20B-2	13U46	OX	OX	OX	OX
Standard Economizer Controls (Not for Title 24)						
Single Enthalpy Control	C1SNSR64FF1	53W64	OX	OX	OX	OX
Differential Enthalpy Control (order 2)	C1SNSR64FF1	53W64	X	X	X	X
High Performance Economizer (Approved for California Title 24 Building Standards)						
High Performance Economizer with Single Temperature Control Downflow or Horizontal Applications - Includes Barometric Relief Dampers and Air Hoods	K1ECON22B-1	10U58	OX	OX	OX	OX
High Performance Economizer Controls (Not for Title 24)						
Single Enthalpy Control	C1SNSR60FF1	10Z75	OX	OX	OX	OX
Differential Enthalpy Control (order 2)	C1SNSR60FF1	10Z75	X	X	X	X
Horizontal Low Profile Barometric Relief Dampers With Exhaust Hood						
Horizontal Low Profile Barometric Relief Dampers With Exhaust Hood	LAGEDH03/15	53K04	X	X	X	X
OUTDOOR AIR						
Outdoor Air Dampers with Outdoor Air Hood						
Motorized	C1DAMP20B-1	14G28	OX	OX	OX	OX
Manual	C1DAMP10B-2	14G29	OX	OX	OX	OX
POWER EXHAUST						
Standard Static	208/230V-3ph - K1PWRE10B-1Y	53W44	X	X	X	X
	460V-3ph - K1PWRE10B-1G	53W45	X	X	X	X
	575V-3ph - K1PWRE10B-1J	53W46	X	X	X	X
ROOF CURBS						
Hybrid Roof Curbs, Downflow						
8 in. height	C1CURB70B-1	11F54	X	X	X	X
14 in. height	C1CURB71B-1	11F55	X	X	X	X
18 in. height	C1CURB72B-1	11F56	X	X	X	X
24 in. height	C1CURB73B-1	11F57	X	X	X	X
Adjustable Pitch Curb						
14 in. height	C1CURB55B-1	54W50	X	X	X	X
CEILING DIFFUSERS						
Step-Down - Order one	RTD11-95	29G04	X			
	RTD11-135	29G05		X	X	
	RTD11-185	29G06				X
Flush - Order one	FD11-95	29G08	X			
	FD11-135	29G09		X	X	
	FD11-185	29G10				X
Transitions (Supply and Return) - Order one	C1DIFF30B-1	12X65	X			
	C1DIFF31B-1	12X66		X	X	
	C1DIFF32B-1	12X67				X

NOTE - Catalog and model numbers shown are for ordering field installed accessories.

OX - Configure To Order (Factory Installed) or Field Installed

O = Configure To Order (Factory Installed)

X = Field Installed

SPECIFICATIONS

General Data		7.5 Ton	7.5 Ton	8.5 Ton	8.5 Ton
Nominal Tonnage		7.5 Ton	7.5 Ton	8.5 Ton	8.5 Ton
Model Number		KHA092S4B	KHA092S4M	KHA102S4B	KHA102S4M
Efficiency Type		Standard	Standard	Standard	Standard
Blower Type		Constant Air Volume (CAV)	Single Zone VAV Supply Fan	Constant Air Volume (CAV)	Single Zone VAV Supply Fan
Cooling Performance	Gross Cooling Capacity - Btuh	91,600	91,600	103,400	103,400
	¹ Net Cooling Capacity - Btuh	89,000	89,000	100,000	100,000
	AHRI Rated Air Flow - cfm	3000	3000	3400	3400
	Total Unit Power - kW	8.1	8.1	9.1	9.1
	¹ EER (Btuh/Watt)	11	11	11	11
	¹ IEER (Btuh/Watt)	12.2	12.5	12.2	12.5
	Refrigerant Type	R-410A	R-410A	R-410A	R-410A
	Refrigerant Charge	12 lbs. 8 oz.	12 lbs. 8 oz.	13 lbs. 8 oz.	13 lbs. 8 oz.
Furnished	Circuit 1 Circuit 2	12 lbs. 0 oz. 12 lbs. 0 oz.	12 lbs. 0 oz. 12 lbs. 0 oz.	13 lbs. 0 oz. 13 lbs. 0 oz.	13 lbs. 0 oz. 13 lbs. 0 oz.
Heating Performance	¹ Total High Heat Capacity - Btuh	89,000	89,000	100,000	100,000
	Total Unit Power - kW	7.9	7.9	8.9	8.9
	¹ C.O.P.	3.3	3.3	3.3	3.3
	¹ Total Low Heat Capacity - Btuh	53,000	53,000	55,000	55,000
	Total Unit Power (kW)	6.9	6.9	7.2	7.2
	¹ C.O.P.	2.25	2.25	2.25	2.25
Electric Heat Available - See page 27		7.5, 15, 22.5, 30 & 45 kW			
Compressor Type (number)		Scroll (2)		Scroll (2)	Scroll (2)
Outdoor Coils	Net face area (total) - sq. ft.	28.8	28.8	28.8	28.8
	Tube diameter - in.	3/8	3/8	3/8	3/8
	Number of rows	2	2	2	2
	Fins per inch	20	20	20	20
Outdoor Coil Fans	Motor - (No.) horsepower	(2) 1/3	(2) 1/3	(2) 1/2	(2) 1/2
	Motor rpm	1075	1075	1075	1075
	Total Motor watts	665	665	775	775
	Diameter - (No.) in.	(2) 24	(2) 24	(2) 24	(2) 24
	Number of blades	3	3	3	3
	Total Air volume - cfm	8200	8200	8600	8600
Indoor Coils	Net face area (total) - sq. ft.	12.8	12.8	12.8	12.8
	Tube diameter - in.	3/8	3/8	3/8	3/8
	Number of rows	3	3	4	4
	Fins per inch	14	14	14	14
	Drain connection - Number and size	(1) 1 in. NPT coupling			
	Expansion device type	Balance port TXV, removable head			
² Indoor Blower and Drive Selection	Nominal motor output	2 hp, 3 hp, 5 hp			
	Maximum usable motor output (US Only)	2.3 hp, 3.45 hp, 5.75 hp			
	Motor - Drive kit number	2 hp ³ Kit 1 590-890 rpm Kit 2 800-1105 rpm Kit 3 795-1195 rpm 3 hp Kit 4 730-970 rpm Kit 5 940-1200 rpm Kit 6 1015-1300 rpm 5 hp Kit 10 900-1135 rpm Kit 11 1040-1315 rpm Kit 12 1125-1425 rpm			
Blower wheel nominal diameter x width - in.		(1) 15 X 15	(1) 15 X 15	(1) 15 X 15	(1) 15 X 15
Filters	Type of filter	Disposable			
	Number and size - in.	(4) 20 x 25 x 2			
Electrical characteristics		208/230V, 460V or 575V - 60 hertz - 3 phase			

NOTE - Net capacity includes evaporator blower motor heat deduction. Gross capacity does not include evaporator blower motor heat deduction.

¹ AHRI Certified to AHRI Standard 340/360:

Cooling Ratings - 95°F outdoor air temperature and 80°F db/67°F wb entering indoor coil air.

High Temperature Heating Ratings - 47°F db/43°F wb outdoor air temperature and 70°F entering indoor coil air.

Low Temperature Heating Ratings - 17°F db/15°F wb outdoor air temperature and 70°F entering indoor coil air.

² Using total air volume and system static pressure requirements determine from blower performance tables rpm and motor output required. Maximum usable output of motors furnished are shown. In Canada, nominal motor output is also maximum usable motor output. If motors of comparable output are used, be sure to keep within the service factor limitations outlined on the motor nameplate.

⁴ Standard motor and drive kit furnished with unit.

NOTE - Units equipped with Single Zone VAV Supply Fan option are limited to a motor service factor of 1.0.

SPECIFICATIONS

General Data		Nominal Tonnage Model Number Efficiency Type Blower Type	10 Ton	10 Ton	12.5 Ton	12.5 Ton
			KHA120S4B Standard Constant Air Volume (CAV)	KHA120S4M Standard Single Zone VAV Supply Fan	KHA150S4B Standard Constant Air Volume (CAV)	KHA150S4M Standard Single Zone VAV Supply Fan
Cooling Performance	Gross Cooling Capacity - Btuh		121,500	121,500	144,300	144,300
	¹ Net Cooling Capacity - Btuh		118,000	118,000	138,000	138,000
	AHRI Rated Air Flow - cfm		3600	3600	4500	4500
	Total Unit Power - kW		10.7	10.7	13.0	13.0
	¹ EER (Btuh/Watt)		11	11.0	10.6	10.6
	¹ IEER (Btuh/Watt)		11.3	12.5	10.7	12.0
	Refrigerant Type		R-410A	R-410A	R-410A	R-410A
Refrigerant Charge	Circuit 1		15 lbs. 0 oz.	15 lbs. 0 oz.	22 lbs. 0 oz.	22 lbs. 0 oz.
	Circuit 2		15 lbs. 0 oz.	15 lbs. 0 oz.	23 lbs. 0 oz.	23 lbs. 0 oz.
Heating Performance	¹ Total High Heat Capacity - Btuh		116,000	116,000	138,000	138,000
	Total Unit Power - kW		10.3	10.3	12.6	12.6
	¹ C.O.P.		3.3	3.30	3.2	3.20
	¹ Total Low Heat Capacity - Btuh		72,000	72,000	82,000	82,000
	Total Unit Power (kW)		9.4	9.4	11.7	11.7
	¹ C.O.P.		2.25	2.25	2.05	2.05
Electric Heat Available - See page 27			15, 22.5, 30, 45 & 60 kW			
Compressor Type (number)			Scroll (2)	Scroll (2)	Scroll (2)	Scroll (2)
Outdoor Coils	Net face area (total) - sq. ft.		28.8	28.8	40.8	40.8
	Tube diameter - in.		3/8	3/8	3/8	3/8
	Number of rows		3	3	3	3
	Fins per inch		20	20	20	20
Outdoor Coil Fans	Motor - (No.) horsepower		(2) 1/2	(2) 1/2	(3) 1/3	(3) 1/3
	Motor rpm		1075	1075	1075	1075
	Total Motor watts		806	806	1150	1150
	Diameter - (No.) in.		(2) 24	(2) 24	(3) 24	(3) 24
	Number of blades		3	3	3	3
	Total Air volume - cfm		8800	8800	11,000	11,000
Indoor Coils	Net face area (total) - sq. ft.		12.8	12.8	12.8	12.8
	Tube diameter - in.		3/8	3/8	3/8	3/8
	Number of rows		4	4	4	4
	Fins per inch		14	14	14	14
Drain connection - Number and size			(1) 1 in. NPT coupling			
	Expansion device type		Balance port TXV, removable head			
² Indoor Blower and Drive Selection	Nominal motor output		2 hp, 3 hp, 5 hp			
	Maximum usable motor output (US Only)		2.3 hp, 3.45 hp, 5.75 hp			
	Motor - Drive kit number		2 hp ³ Kit 1 590-890 rpm Kit 2 800-1105 rpm Kit 3 795-1195 rpm 3 hp Kit 4 730-970 rpm Kit 5 940-1200 rpm Kit 6 1015-1300 rpm 5 hp Kit 10 900-1135 rpm Kit 11 1040-1315 rpm Kit 12 1125-1425 rpm			
Blower wheel nominal diameter x width - in.			(1) 15 X 15	(1) 15 X 15	(1) 15 X 15	(1) 15 X 15
Filters	Type of filter		Disposable			
	Number and size - in.		(4) 20 x 25 x 2			
Electrical characteristics			208/230V, 460V or 575V - 60 hertz - 3 phase			

NOTE - Net capacity includes evaporator blower motor heat deduction. Gross capacity does not include evaporator blower motor heat deduction.

¹ AHRI Certified to AHRI Standard 340/360:

Cooling Ratings - 95°F outdoor air temperature and 80°F db/67°F wb entering indoor coil air.

High Temperature Heating Ratings - 47°F db/43°F wb outdoor air temperature and 70°F entering indoor coil air.

Low Temperature Heating Ratings - 17°F db/15°F wb outdoor air temperature and 70°F entering indoor coil air.

² Using total air volume and system static pressure requirements determine from blower performance tables rpm and motor output required. Maximum usable output of motors furnished are shown. In Canada, nominal motor output is also maximum usable motor output. If motors of comparable output are used, be sure to keep within the service factor limitations outlined on the motor nameplate.

⁴ Standard motor and drive kit furnished with unit.

NOTE - Units equipped with Single Zone VAV Supply Fan option are limited to a motor service factor of 1.0.

RATINGS

NOTE – For Temperatures and Capacities not shown in tables, see bulletin – Cooling Unit Rating Table Correction Factor Data in Miscellaneous Engineering Data section.

7.5 TON COOLING STANDARD EFFICIENCY KHA092S4 (1ST STAGE) - CONSTANT AIR VOLUME

Entering Wet Bulb Temperature	Total Air Volume	Outdoor Air Temperature Entering Outdoor Coil																			
		65°F					75°F					85°F					95°F				
		Total Cool Cap.	Comp. Motor Input	Sensible To Total Ratio (S/T) Dry Bulb			Total Cool Cap.	Comp. Motor Input	Sensible To Total Ratio (S/T) Dry Bulb			Total Cool Cap.	Comp. Motor Input	Sensible To Total Ratio (S/T) Dry Bulb			Total Cool Cap.	Comp. Motor Input	Sensible To Total Ratio (S/T) Dry Bulb		
				75°F	80°F	85°F			75°F	80°F	85°F			75°F	80°F	85°F			75°F	80°F	85°F
cfm	kBtuh	kW	75°F	80°F	85°F	kBtuh	kW	75°F	80°F	85°F	kBtuh	kW	75°F	80°F	85°F	kBtuh	kW	75°F	80°F	85°F	
63°F	2400	48.9	2.15	0.61	0.75	0.93	46.1	2.43	0.61	0.77	0.96	43.2	2.75	0.62	0.8	0.99	40.2	3.12	0.63	0.83	1
	3000	51.7	2.16	0.65	0.85	1	48.7	2.44	0.66	0.88	1	45.7	2.76	0.67	0.91	1	42.5	3.12	0.7	0.95	1
	3600	53.8	2.16	0.7	0.94	1	50.8	2.45	0.72	0.97	1	47.6	2.76	0.75	1	1	44.5	3.13	0.78	1	1
67°F	2400	52	2.16	0.48	0.59	0.7	49.2	2.44	0.48	0.59	0.72	46.2	2.76	0.48	0.6	0.75	43.1	3.12	0.48	0.61	0.78
	3000	54.9	2.16	0.51	0.63	0.8	51.9	2.45	0.51	0.64	0.83	48.7	2.77	0.51	0.65	0.86	45.3	3.13	0.52	0.67	0.9
	3600	57.1	2.17	0.53	0.67	0.89	53.9	2.45	0.54	0.69	0.93	50.5	2.77	0.54	0.72	0.96	46.9	3.13	0.55	0.75	0.99
71°F	2400	55.1	2.16	0.37	0.47	0.57	52.3	2.45	0.37	0.47	0.57	49.1	2.77	0.36	0.47	0.58	45.9	3.13	0.35	0.48	0.59
	3000	58.2	2.17	0.38	0.5	0.61	55.1	2.45	0.38	0.5	0.62	51.7	2.77	0.37	0.51	0.63	48.1	3.14	0.37	0.51	0.65
	3600	60.4	2.18	0.39	0.52	0.65	57.1	2.46	0.39	0.53	0.66	53.6	2.78	0.39	0.54	0.69	50	3.14	0.39	0.55	0.72

7.5 TON COOLING STANDARD EFFICIENCY KHA092S4 (2ND STAGE) - CONSTANT AIR VOLUME

Entering Wet Bulb Temperature	Total Air Volume	Outdoor Air Temperature Entering Outdoor Coil																			
		85°F					95°F					105°F					115°F				
		Total Cool Cap.	Comp. Motor Input	Sensible To Total Ratio (S/T) Dry Bulb			Total Cool Cap.	Comp. Motor Input	Sensible To Total Ratio (S/T) Dry Bulb			Total Cool Cap.	Comp. Motor Input	Sensible To Total Ratio (S/T) Dry Bulb			Total Cool Cap.	Comp. Motor Input	Sensible To Total Ratio (S/T) Dry Bulb		
				75°F	80°F	85°F			75°F	80°F	85°F			75°F	80°F	85°F			75°F	80°F	85°F
cfm	kBtuh	kW	75°F	80°F	85°F	kBtuh	kW	75°F	80°F	85°F	kBtuh	kW	75°F	80°F	85°F	kBtuh	kW	75°F	80°F	85°F	
63°F	2400	87.3	5.43	0.7	0.85	0.99	81.3	6.15	0.71	0.87	1	74.9	6.99	0.72	0.9	1	67.7	7.97	0.74	0.95	1
	3000	92.5	5.44	0.75	0.93	1	86	6.16	0.77	0.96	1	79.2	7	0.8	0.99	1	72.4	7.98	0.83	1	1
	3600	96.3	5.45	0.81	1	1	90	6.17	0.84	1	1	83.7	7	0.87	1	1	76.7	7.98	0.91	1	1
67°F	2400	93.3	5.44	0.54	0.68	0.81	87.2	6.17	0.54	0.69	0.83	80.3	6.99	0.55	0.7	0.87	72.9	7.97	0.55	0.72	0.9
	3000	98.4	5.45	0.58	0.73	0.9	91.6	6.17	0.58	0.75	0.93	84.4	7.01	0.59	0.77	0.96	76.7	7.99	0.6	0.8	1
	3600	102.1	5.46	0.61	0.79	0.97	94.9	6.18	0.62	0.81	1	87.1	7	0.63	0.85	1	79.2	7.98	0.65	0.89	1
71°F	2400	99.3	5.45	0.4	0.53	0.65	92.7	6.17	0.4	0.53	0.66	85.8	7.01	0.39	0.54	0.68	78.1	7.97	0.39	0.55	0.7
	3000	104.5	5.46	0.42	0.57	0.71	97.4	6.18	0.42	0.57	0.73	90	7.02	0.41	0.58	0.75	81.9	7.98	0.41	0.6	0.78
	3600	108.3	5.48	0.44	0.6	0.77	101.1	6.19	0.44	0.61	0.79	93.2	7.02	0.43	0.63	0.82	84.6	7.98	0.43	0.64	0.86

7.5 TON HEATING STANDARD EFFICIENCY KHA092S4 - CONSTANT AIR VOLUME

Indoor Coil Air Volume 70°F Dry Bulb cfm	Air Temperature Entering Outdoor Coil									
	65°F		45°F		25°F		5°F		-15°F	
	Total Heating Capacity	Comp. Motor Input	Total Heating Capacity	Comp. Motor Input	Total Heating Capacity	Comp. Motor Input	Total Heating Capacity	Comp. Motor Input	Total Heating Capacity	Comp. Motor Input
2400	109.2	7.13	83.2	6.60	56.4	6.13	37.0	5.20	18.4	3940
3000	111.1	6.64	85.2	6.12	58.3	5.64	38.9	4.72	20.3	3455
3600	112.8	6.34	86.8	5.82	60.0	5.34	40.6	4.42	22.0	3155

RATINGS

NOTE - For Temperatures and Capacities not shown in tables, see bulletin - Cooling Unit Rating Table Correction Factor Data in Miscellaneous Engineering Data section.

8.5 TON COOLING STANDARD EFFICIENCY KHA102S4 (1ST STAGE) - CONSTANT AIR VOLUME

Entering Wet Bulb Temperature	Total Air Volume	Outdoor Air Temperature Entering Outdoor Coil																			
		65°F					75°F					85°F					95°F				
		Total Cool Cap.	Comp. Motor Input	Sensible To Total Ratio (S/T)			Total Cool Cap.	Comp. Motor Input	Sensible To Total Ratio (S/T)			Total Cool Cap.	Comp. Motor Input	Sensible To Total Ratio (S/T)			Total Cool Cap.	Comp. Motor Input	Sensible To Total Ratio (S/T)		
				Dry Bulb					Dry Bulb					Dry Bulb					Dry Bulb		
		cfm	kBtuh	kW	75°F	80°F	85°F	kBtuh	kW	75°F	80°F	85°F	kBtuh	kW	75°F	80°F	85°F	kBtuh	kW	75°F	80°F
63°F	2720	53	2.42	0.63	0.77	0.95	50.3	2.73	0.63	0.79	0.98	47.4	3.08	0.64	0.82	1	44.4	3.49	0.66	0.85	1
	3400	55.9	2.43	0.67	0.87	1	53	2.74	0.68	0.9	1	49.8	3.09	0.7	0.94	1	46.6	3.5	0.73	0.98	1
	4080	58.1	2.44	0.73	0.97	1	54.9	2.75	0.75	0.99	1	52.1	3.1	0.78	1	1	49	3.5	0.81	1	1
67°F	2720	56.4	2.43	0.5	0.61	0.72	53.7	2.74	0.5	0.61	0.74	50.7	3.1	0.5	0.63	0.77	47.5	3.5	0.51	0.64	0.8
	3400	59.3	2.44	0.53	0.65	0.82	56.2	2.75	0.53	0.66	0.85	53.1	3.1	0.54	0.68	0.89	49.6	3.51	0.55	0.7	0.93
	4080	61.4	2.45	0.56	0.7	0.92	58.1	2.76	0.56	0.72	0.96	54.7	3.11	0.57	0.75	0.99	51.1	3.51	0.58	0.78	1
71°F	2720	60.1	2.45	0.38	0.48	0.59	57	2.76	0.38	0.49	0.59	54	3.1	0.38	0.49	0.6	50.5	3.51	0.37	0.5	0.62
	3400	63	2.46	0.39	0.51	0.63	59.6	2.76	0.39	0.52	0.64	56.5	3.12	0.39	0.53	0.66	52.9	3.52	0.39	0.54	0.68
	4080	65.1	2.46	0.41	0.55	0.68	61.8	2.77	0.41	0.56	0.7	58.1	3.12	0.41	0.56	0.72	54.5	3.52	0.41	0.57	0.75

8.5 TON COOLING STANDARD EFFICIENCY KHA102S4 (2ND STAGE) - CONSTANT AIR VOLUME

Entering Wet Bulb Temperature	Total Air Volume	Outdoor Air Temperature Entering Outdoor Coil																			
		85°F					95°F					105°F					115°F				
		Total Cool Cap.	Comp. Motor Input	Sensible To Total Ratio (S/T)			Total Cool Cap.	Comp. Motor Input	Sensible To Total Ratio (S/T)			Total Cool Cap.	Comp. Motor Input	Sensible To Total Ratio (S/T)			Total Cool Cap.	Comp. Motor Input	Sensible To Total Ratio (S/T)		
				Dry Bulb					Dry Bulb					Dry Bulb					Dry Bulb		
		cfm	kBtuh	kW	75°F	80°F	85°F	kBtuh	kW	75°F	80°F	85°F	kBtuh	kW	75°F	80°F	85°F	kBtuh	kW	75°F	80°F
63°F	2720	98.8	6.36	0.71	0.87	1	92.4	7.2	0.73	0.89	1	85.6	8.16	0.74	0.92	1	78.4	9.32	0.77	0.97	1
	3400	103.8	6.38	0.77	0.95	1	97.2	7.21	0.8	0.99	1	90.4	8.18	0.82	1	1	83.5	9.31	0.86	1	1
	4080	108.4	6.4	0.84	1	1	102.1	7.23	0.86	1	1	95.7	8.2	0.9	1	1	88.4	9.34	0.94	1	1
67°F	2720	105.5	6.39	0.56	0.69	0.83	98.9	7.22	0.56	0.71	0.85	91.4	8.18	0.57	0.72	0.89	83.8	9.32	0.58	0.75	0.93
	3400	110.5	6.41	0.6	0.75	0.92	103.4	7.23	0.61	0.77	0.95	95.6	8.2	0.61	0.8	0.99	87.2	9.33	0.63	0.83	1
	4080	113.8	6.41	0.63	0.82	0.99	106.6	7.24	0.64	0.84	1	98.5	8.21	0.66	0.88	1	89.8	9.32	0.68	0.92	1
71°F	2720	112.4	6.41	0.42	0.55	0.67	105.2	7.24	0.42	0.55	0.69	97.7	8.19	0.41	0.56	0.7	89.7	9.34	0.41	0.57	0.73
	3400	117.5	6.43	0.44	0.59	0.73	110.2	7.26	0.44	0.6	0.75	102	8.22	0.43	0.61	0.78	93.4	9.34	0.43	0.62	0.81
	4080	121	6.44	0.45	0.62	0.79	113.4	7.27	0.45	0.64	0.82	105.2	8.23	0.46	0.66	0.85	95.8	9.34	0.46	0.67	0.89

8.5 TON HEATING STANDARD EFFICIENCY KHA102S4 - CONSTANT AIR VOLUME

Indoor Coil Air Volume 70°F Dry Bulb cfm	Air Temperature Entering Outdoor Coil									
	65°F		45°F		25°F		5°F		-15°F	
	Total Heating Capacity	Comp. Motor Input	Total Heating Capacity	Comp. Motor Input	Total Heating Capacity	Comp. Motor Input	Total Heating Capacity	Comp. Motor Input	Total Heating Capacity	Comp. Motor Input
	kBtuh	kW	kBtuh	kW	kBtuh	kW	kBtuh	kW	kBtuh	kW
2720	124.0	7.58	93.6	6.91	62.2	6.24	40.0	5.44	20.1	4120
3400	126.0	7.09	95.6	6.43	64.1	5.75	41.9	4.95	22.1	3635
4080	128.0	6.79	97.6	6.12	66.2	5.44	43.9	4.64	24.1	3325

RATINGS

NOTE – For Temperatures and Capacities not shown in tables, see bulletin – Cooling Unit Rating Table Correction Factor Data in Miscellaneous Engineering Data section.

10 TON COOLING STANDARD EFFICIENCY KHA120S4 (1ST STAGE) - CONSTANT AIR VOLUME

Entering Wet Bulb Temperature	Total Air Volume	Outdoor Air Temperature Entering Outdoor Coil																							
		65°F						75°F						85°F						95°F					
		Total Cool Cap.	Comp. Motor Input	Sensible To Total Ratio (S/T) Dry Bulb			Total Cool Cap.	Comp. Motor Input	Sensible To Total Ratio (S/T) Dry Bulb			Total Cool Cap.	Comp. Motor Input	Sensible To Total Ratio (S/T) Dry Bulb			Total Cool Cap.	Comp. Motor Input	Sensible To Total Ratio (S/T) Dry Bulb						
				75°F	80°F	85°F			75°F	80°F	85°F			75°F	80°F	85°F			75°F	80°F	85°F				
cfm	kBtuh	kW	75°F	80°F	85°F	kBtuh	kW	75°F	80°F	85°F	kBtuh	kW	75°F	80°F	85°F	kBtuh	kW	75°F	80°F	85°F					
63°F	3200	64.2	2.87	0.66	0.8	0.94	60.6	3.26	0.67	0.81	0.96	56.8	3.7	0.67	0.83	0.99	52.9	4.18	0.68	0.85	1				
	4000	67.9	2.9	0.71	0.87	1	64	3.29	0.72	0.9	1	60.1	3.72	0.73	0.92	1	56	4.21	0.75	0.96	1				
	4800	70.6	2.92	0.75	0.95	1	66.6	3.32	0.78	0.97	1	62.6	3.75	0.79	0.99	1	58.5	4.24	0.82	1	1				
67°F	3200	68.4	2.9	0.53	0.64	0.76	64.8	3.3	0.52	0.64	0.77	61	3.73	0.52	0.65	0.79	56.9	4.22	0.52	0.66	0.81				
	4000	72.2	2.93	0.55	0.68	0.83	68.3	3.33	0.56	0.7	0.86	64.2	3.76	0.56	0.71	0.88	59.7	4.25	0.56	0.72	0.91				
	4800	74.7	2.95	0.58	0.73	0.91	70.7	3.35	0.59	0.75	0.94	66.4	3.79	0.59	0.77	0.97	61.8	4.27	0.6	0.8	0.99				
71°F	3200	73.3	2.93	0.4	0.51	0.62	69.1	3.34	0.4	0.51	0.62	65.1	3.77	0.39	0.51	0.63	60.9	4.26	0.38	0.51	0.64				
	4000	76.6	2.97	0.41	0.54	0.66	72.7	3.37	0.41	0.55	0.67	68.3	3.81	0.41	0.55	0.69	63.7	4.29	0.4	0.55	0.7				
	4800	79.5	3	0.43	0.57	0.71	75.1	3.39	0.42	0.57	0.72	70.6	3.84	0.42	0.59	0.75	65.8	4.32	0.42	0.6	0.77				

10 TON COOLING STANDARD EFFICIENCY KHA120S4 (2ND STAGE) - CONSTANT AIR VOLUME

Entering Wet Bulb Temperature	Total Air Volume	Outdoor Air Temperature Entering Outdoor Coil																							
		85°F						95°F						105°F						115°F					
		Total Cool Cap.	Comp. Motor Input	Sensible To Total Ratio (S/T) Dry Bulb			Total Cool Cap.	Comp. Motor Input	Sensible To Total Ratio (S/T) Dry Bulb			Total Cool Cap.	Comp. Motor Input	Sensible To Total Ratio (S/T) Dry Bulb			Total Cool Cap.	Comp. Motor Input	Sensible To Total Ratio (S/T) Dry Bulb						
				75°F	80°F	85°F			75°F	80°F	85°F			75°F	80°F	85°F			75°F	80°F	85°F				
cfm	kBtuh	kW	75°F	80°F	85°F	kBtuh	kW	75°F	80°F	85°F	kBtuh	kW	75°F	80°F	85°F	kBtuh	kW	75°F	80°F	85°F					
63°F	3200	117.9	7.41	0.7	0.85	0.99	110	8.38	0.71	0.87	1	101.4	9.49	0.73	0.9	1	92.3	10.78	0.75	0.94	1				
	4000	124.8	7.47	0.76	0.93	1	116.4	8.44	0.78	0.96	1	107.2	9.55	0.8	0.99	1	98	10.83	0.83	1	1				
	4800	130	7.52	0.82	1	1	121.5	8.49	0.84	1	1	113.1	9.61	0.87	1	1	104.1	10.89	0.91	1	1				
67°F	3200	126.6	7.48	0.55	0.68	0.82	118.3	8.46	0.55	0.69	0.84	109.1	9.57	0.55	0.71	0.86	99.4	10.85	0.55	0.73	0.9				
	4000	133.2	7.55	0.58	0.74	0.9	124	8.52	0.59	0.75	0.93	114.5	9.63	0.6	0.78	0.96	104.1	10.9	0.61	0.81	0.99				
	4800	137.8	7.6	0.62	0.8	0.97	128.3	8.57	0.63	0.82	0.99	118.1	9.67	0.64	0.85	1	107.2	10.93	0.66	0.89	1				
71°F	3200	135.1	7.57	0.41	0.54	0.66	126.5	8.55	0.4	0.54	0.67	116.9	9.66	0.4	0.54	0.69	106.7	10.91	0.39	0.55	0.7				
	4000	141.8	7.64	0.43	0.57	0.72	132.2	8.61	0.41	0.58	0.73	122.7	9.72	0.42	0.59	0.76	111.9	10.99	0.41	0.6	0.79				
	4800	146.7	7.69	0.44	0.61	0.78	136.8	8.67	0.44	0.62	0.8	126.5	9.77	0.44	0.63	0.84	115.3	11.02	0.44	0.65	0.86				

10 TON HEATING STANDARD EFFICIENCY KHA120S4 - CONSTANT AIR VOLUME

Indoor Coil Air Volume 70°F Dry Bulb cfm	Air Temperature Entering Outdoor Coil									
	65°F		45°F		25°F		5°F		-15°F	
	Total Heating Capacity	Comp. Motor Input	Total Heating Capacity	Comp. Motor Input	Total Heating Capacity	Comp. Motor Input	Total Heating Capacity	Comp. Motor Input	Total Heating Capacity	Comp. Motor Input
3200	141.7	9.39	109.6	8.57	76.1	7.74	52.6	6.77	25.4	5130
4000	144.9	8.77	112.9	7.95	79.4	7.12	55.9	6.15	28.7	4510
4800	148.1	8.37	116.1	7.55	82.6	6.72	59.0	5.74	31.9	4105

RATINGS

NOTE - For Temperatures and Capacities not shown in tables, see bulletin - Cooling Unit Rating Table Correction Factor Data in Miscellaneous Engineering Data section.

12.5 TON COOLING STANDARD EFFICIENCY KHA150S4 (1ST STAGE) - CONSTANT AIR VOLUME

Entering Wet Bulb Temperature	Total Air Volume	Outdoor Air Temperature Entering Outdoor Coil																			
		65°F					75°F					85°F					95°F				
		Total Cool Cap.	Comp. Motor Input	Sensible To Total Ratio (S/T) Dry Bulb			Total Cool Cap.	Comp. Motor Input	Sensible To Total Ratio (S/T) Dry Bulb			Total Cool Cap.	Comp. Motor Input	Sensible To Total Ratio (S/T) Dry Bulb			Total Cool Cap.	Comp. Motor Input	Sensible To Total Ratio (S/T) Dry Bulb		
				75°F	80°F	85°F			75°F	80°F	85°F			75°F	80°F	85°F			75°F	80°F	85°F
cfm	kBtuh	kW	75°F	80°F	85°F	kBtuh	kW	75°F	80°F	85°F	kBtuh	kW	75°F	80°F	85°F	kBtuh	kW	75°F	80°F	85°F	
63°F	3800	75.5	3.48	0.64	0.79	0.95	71.4	3.88	0.64	0.8	0.97	67	4.32	0.65	0.82	0.99	62	4.79	0.65	0.85	1
	4400	78.5	3.49	0.67	0.85	1	74.2	3.89	0.67	0.86	1	69.6	4.32	0.68	0.89	1	64.5	4.79	0.7	0.92	1
	5000	81	3.5	0.7	0.9	1	76.7	3.89	0.72	0.92	1	71.8	4.32	0.72	0.95	1	67	4.8	0.75	0.98	1
67°F	3800	81.1	3.5	0.5	0.62	0.75	76.9	3.9	0.5	0.62	0.76	72.2	4.32	0.5	0.62	0.78	67.1	4.8	0.49	0.63	0.8
	4400	84	3.51	0.52	0.64	0.8	79.7	3.9	0.52	0.65	0.82	75	4.33	0.52	0.66	0.84	69.7	4.8	0.52	0.67	0.87
	5000	86.4	3.52	0.54	0.68	0.85	82.1	3.9	0.54	0.69	0.88	77.2	4.33	0.54	0.71	0.9	71.5	4.8	0.54	0.72	0.93
71°F	3800	86.8	3.52	0.39	0.49	0.59	82.3	3.9	0.38	0.49	0.6	77.6	4.33	0.37	0.49	0.6	72.5	4.8	0.36	0.49	0.61
	4400	89.9	3.52	0.39	0.51	0.62	85.3	3.91	0.39	0.51	0.63	80.5	4.34	0.38	0.51	0.64	75.2	4.81	0.37	0.51	0.65
	5000	92.5	3.53	0.4	0.53	0.65	87.9	3.92	0.4	0.53	0.66	82.7	4.34	0.39	0.54	0.67	77.2	4.81	0.38	0.53	0.69

12.5 TON COOLING STANDARD EFFICIENCY KHA150S4 (2ND STAGE) - CONSTANT AIR VOLUME

Entering Wet Bulb Temperature	Total Air Volume	Outdoor Air Temperature Entering Outdoor Coil																			
		85°F					95°F					105°F					115°F				
		Total Cool Cap.	Comp. Motor Input	Sensible To Total Ratio (S/T) Dry Bulb			Total Cool Cap.	Comp. Motor Input	Sensible To Total Ratio (S/T) Dry Bulb			Total Cool Cap.	Comp. Motor Input	Sensible To Total Ratio (S/T) Dry Bulb			Total Cool Cap.	Comp. Motor Input	Sensible To Total Ratio (S/T) Dry Bulb		
				75°F	80°F	85°F			75°F	80°F	85°F			75°F	80°F	85°F			75°F	80°F	85°F
cfm	kBtuh	kW	75°F	80°F	85°F	kBtuh	kW	75°F	80°F	85°F	kBtuh	kW	75°F	80°F	85°F	kBtuh	kW	75°F	80°F	85°F	
63°F	3800	138.4	8.45	0.7	0.86	1	128.4	9.38	0.71	0.88	1	117.7	10.42	0.72	0.9	1	106.5	11.6	0.74	0.94	1
	4400	144	8.45	0.74	0.91	1	133.6	9.39	0.76	0.94	1	122.8	10.43	0.77	0.97	1	111.6	11.6	0.8	1	1
	5000	148.6	8.45	0.78	0.96	1	138.6	9.39	0.8	0.98	1	127.6	10.43	0.82	1	1	116.8	11.61	0.85	1	1
67°F	3800	149.2	8.46	0.54	0.68	0.82	138.7	9.39	0.54	0.69	0.84	128.2	10.43	0.54	0.7	0.86	116.2	11.6	0.54	0.72	0.89
	4400	155	8.47	0.57	0.72	0.87	144.3	9.39	0.57	0.73	0.89	132.8	10.42	0.57	0.75	0.93	120.4	11.59	0.58	0.77	0.96
	5000	159.6	8.47	0.59	0.76	0.92	148.7	9.39	0.59	0.77	0.95	136.9	10.43	0.6	0.8	0.98	124.6	11.62	0.61	0.82	1
71°F	3800	160.3	8.47	0.4	0.53	0.66	149.9	9.39	0.39	0.53	0.67	138.9	10.44	0.38	0.53	0.68	126.5	11.61	0.37	0.54	0.69
	4400	166.4	8.48	0.41	0.56	0.69	155.5	9.4	0.41	0.56	0.71	143.7	10.43	0.4	0.56	0.72	131.4	11.62	0.39	0.57	0.74
	5000	171	8.49	0.42	0.58	0.74	159.7	9.4	0.41	0.58	0.75	148.1	10.44	0.41	0.59	0.77	135.5	11.62	0.41	0.6	0.8

12.5 TON HEATING STANDARD EFFICIENCY KHA150S4 - CONSTANT AIR VOLUME

Indoor Coil Air Volume 70°F Dry Bulb cfm	Air Temperature Entering Outdoor Coil									
	65°F		45°F		25°F		5°F		-15°F	
	Total Heating Capacity	Comp. Motor Input	Total Heating Capacity	Comp. Motor Input	Total Heating Capacity	Comp. Motor Input	Total Heating Capacity	Comp. Motor Input	Total Heating Capacity	Comp. Motor Input
3800	167.2	10.04	127.6	9.22	86.4	8.39	58.2	7.34	28.6	5465
4400	170.6	9.68	131.1	8.86	89.8	8.03	61.7	6.97	32.0	5100
5000	174.0	9.41	134.5	8.59	93.2	7.76	65.1	6.71	35.4	4835

RATINGS

NOTE – For Temperatures and Capacities not shown in tables, see bulletin – Cooling Unit Rating Table Correction Factor Data in Miscellaneous Engineering Data section.

7.5 TON COOLING STANDARD EFFICIENCY KHA092S4 (1ST STAGE) - SINGLE ZONE VAV SUPPLY FAN SUPPLY AIR BLOWER

Entering Wet Bulb Temperature	Total Air Volume	Outdoor Air Temperature Entering Outdoor Coil																			
		65°F					75°F					85°F					95°F				
		Total Cool Cap.	Comp. Motor Input	Sensible To Total Ratio (S/T) Dry Bulb			Total Cool Cap.	Comp. Motor Input	Sensible To Total Ratio (S/T) Dry Bulb			Total Cool Cap.	Comp. Motor Input	Sensible To Total Ratio (S/T) Dry Bulb			Total Cool Cap.	Comp. Motor Input	Sensible To Total Ratio (S/T) Dry Bulb		
				75°F	80°F	85°F			75°F	80°F	85°F			75°F	80°F	85°F			75°F	80°F	85°F
cfm	kBtuh	kW	75°F	80°F	85°F	kBtuh	kW	75°F	80°F	85°F	kBtuh	kW	75°F	80°F	85°F	kBtuh	kW	75°F	80°F	85°F	
63°F	1680	44.1	2.13	0.57	0.69	0.81	41.7	2.42	0.57	0.69	0.83	39.2	2.74	0.58	0.7	0.85	36.5	3.11	0.58	0.72	0.87
	2100	47.5	2.14	0.6	0.74	0.89	44.9	2.43	0.61	0.76	0.91	42.2	2.75	0.61	0.77	0.94	39.2	3.11	0.62	0.8	0.97
	2520	50.1	2.15	0.64	0.8	0.96	47.2	2.43	0.65	0.82	0.98	44.3	2.75	0.66	0.85	1	41.2	3.12	0.67	0.87	1
67°F	1680	47.1	2.14	0.46	0.55	0.65	44.6	2.43	0.46	0.55	0.65	42	2.75	0.46	0.55	0.66	39.2	3.12	0.45	0.56	0.68
	2100	50.6	2.15	0.48	0.58	0.7	47.9	2.44	0.48	0.58	0.72	45.1	2.75	0.48	0.59	0.73	42	3.12	0.48	0.6	0.75
	2520	53.3	2.16	0.5	0.61	0.76	50.4	2.44	0.5	0.62	0.78	47.3	2.76	0.5	0.63	0.8	44.1	3.12	0.5	0.65	0.83
71°F	1680	50.1	2.15	0.37	0.45	0.53	47.5	2.43	0.36	0.45	0.53	44.7	2.75	0.35	0.44	0.53	41.9	3.12	0.34	0.44	0.54
	2100	53.8	2.16	0.37	0.47	0.56	50.9	2.44	0.37	0.47	0.56	47.9	2.76	0.36	0.47	0.57	44.8	3.13	0.35	0.47	0.58
	2520	56.5	2.17	0.38	0.49	0.59	53.5	2.45	0.38	0.49	0.6	50.3	2.77	0.37	0.49	0.61	46.9	3.13	0.36	0.49	0.62

7.5 TON COOLING STANDARD EFFICIENCY KHA092S4 (2ND STAGE) - SINGLE ZONE VAV SUPPLY FAN SUPPLY AIR BLOWER

Entering Wet Bulb Temperature	Total Air Volume	Outdoor Air Temperature Entering Outdoor Coil																			
		85°F					95°F					105°F					115°F				
		Total Cool Cap.	Comp. Motor Input	Sensible To Total Ratio (S/T) Dry Bulb			Total Cool Cap.	Comp. Motor Input	Sensible To Total Ratio (S/T) Dry Bulb			Total Cool Cap.	Comp. Motor Input	Sensible To Total Ratio (S/T) Dry Bulb			Total Cool Cap.	Comp. Motor Input	Sensible To Total Ratio (S/T) Dry Bulb		
				75°F	80°F	85°F			75°F	80°F	85°F			75°F	80°F	85°F			75°F	80°F	85°F
cfm	kBtuh	kW	75°F	80°F	85°F	kBtuh	kW	75°F	80°F	85°F	kBtuh	kW	75°F	80°F	85°F	kBtuh	kW	75°F	80°F	85°F	
63°F	2400	87.3	5.43	0.7	0.85	0.99	81.3	6.15	0.71	0.87	1	74.9	6.99	0.72	0.9	1	67.7	7.97	0.74	0.95	1
	3000	92.5	5.44	0.75	0.93	1	86	6.16	0.77	0.96	1	79.2	7	0.8	0.99	1	72.4	7.98	0.83	1	1
	3600	96.3	5.45	0.81	1	1	90	6.17	0.84	1	1	83.7	7	0.87	1	1	76.7	7.98	0.91	1	1
67°F	2400	93.3	5.44	0.54	0.68	0.81	87.2	6.17	0.54	0.69	0.83	80.3	6.99	0.55	0.7	0.87	72.9	7.97	0.55	0.72	0.9
	3000	98.4	5.45	0.58	0.73	0.9	91.6	6.17	0.58	0.75	0.93	84.4	7.01	0.59	0.77	0.96	76.7	7.99	0.6	0.8	1
	3600	102.1	5.46	0.61	0.79	0.97	94.9	6.18	0.62	0.81	1	87.1	7	0.63	0.85	1	79.2	7.98	0.65	0.89	1
71°F	2400	99.3	5.45	0.4	0.53	0.65	92.7	6.17	0.4	0.53	0.66	85.8	7.01	0.39	0.54	0.68	78.1	7.97	0.39	0.55	0.7
	3000	104.5	5.46	0.42	0.57	0.71	97.4	6.18	0.42	0.57	0.73	90	7.02	0.41	0.58	0.75	81.9	7.98	0.41	0.6	0.78
	3600	108.3	5.48	0.44	0.6	0.77	101.1	6.19	0.44	0.61	0.79	93.2	7.02	0.43	0.63	0.82	84.6	7.98	0.43	0.64	0.86

7.5 TON HEATING STANDARD EFFICIENCY KHA092S4 - SINGLE ZONE VAV SUPPLY FAN SUPPLY AIR BLOWER

Indoor Coil Air Volume 70°F Dry Bulb cfm	Air Temperature Entering Outdoor Coil									
	65°F		45°F		25°F		5°F		-15°F	
	Total Heating Capacity	Comp. Motor Input	Total Heating Capacity	Comp. Motor Input	Total Heating Capacity	Comp. Motor Input	Total Heating Capacity	Comp. Motor Input	Total Heating Capacity	Comp. Motor Input
	kBtuh	kW	kBtuh	kW	kBtuh	kW	kBtuh	kW	kBtuh	kW
2400	109.2	7.13	83.2	6.60	56.4	6.13	37.0	5.20	18.4	3940
3000	111.1	6.64	85.2	6.12	58.3	5.64	38.9	4.72	20.3	3455
3600	112.8	6.34	86.8	5.82	60.0	5.34	40.6	4.42	22.0	3155

RATINGS

NOTE - For Temperatures and Capacities not shown in tables, see bulletin - Cooling Unit Rating Table Correction Factor Data in Miscellaneous Engineering Data section.

8.5 TON COOLING STANDARD EFFICIENCY KHA102S4 (1ST STAGE) - SINGLE ZONE VAV SUPPLY FAN SUPPLY AIR BLOWER

Entering Wet Bulb Temperature	Total Air Volume	Outdoor Air Temperature Entering Outdoor Coil																			
		65°F					75°F					85°F					95°F				
		Total Cool Cap.	Comp. Motor Input	Sensible To Total Ratio (S/T)			Total Cool Cap.	Comp. Motor Input	Sensible To Total Ratio (S/T)			Total Cool Cap.	Comp. Motor Input	Sensible To Total Ratio (S/T)			Total Cool Cap.	Comp. Motor Input	Sensible To Total Ratio (S/T)		
				Dry Bulb					Dry Bulb					Dry Bulb					Dry Bulb		
		cfm	kBtuh	kW	75°F	80°F	85°F	kBtuh	kW	75°F	80°F	85°F	kBtuh	kW	75°F	80°F	85°F	kBtuh	kW	75°F	80°F
63°F	1920	48.3	2.39	0.58	0.69	0.82	46	2.71	0.58	0.7	0.84	43.4	3.06	0.58	0.71	0.86	40.8	3.47	0.59	0.73	0.89
	2400	51.7	2.41	0.6	0.75	0.9	49.1	2.72	0.61	0.77	0.93	46.3	3.07	0.62	0.78	0.96	43.3	3.47	0.63	0.81	0.99
	2880	54.2	2.42	0.64	0.81	0.98	51.4	2.73	0.66	0.83	1	48.5	3.08	0.67	0.86	1	45.3	3.48	0.69	0.89	1
67°F	1920	51.8	2.41	0.47	0.56	0.65	49.3	2.72	0.47	0.56	0.66	46.5	3.07	0.47	0.56	0.67	43.7	3.48	0.46	0.57	0.69
	2400	55.1	2.42	0.48	0.58	0.71	52.5	2.73	0.48	0.59	0.72	49.5	3.08	0.49	0.6	0.74	46.4	3.49	0.49	0.61	0.77
	2880	57.6	2.43	0.5	0.62	0.77	54.8	2.74	0.51	0.63	0.79	51.7	3.09	0.51	0.65	0.82	48.3	3.49	0.51	0.66	0.85
71°F	1920	55.1	2.42	0.37	0.45	0.53	52.5	2.73	0.36	0.45	0.54	49.7	3.08	0.36	0.45	0.54	46.7	3.49	0.35	0.45	0.54
	2400	58.6	2.43	0.38	0.47	0.56	55.8	2.74	0.37	0.47	0.57	52.7	3.09	0.37	0.47	0.58	49.5	3.5	0.37	0.48	0.59
	2880	61.2	2.44	0.38	0.49	0.6	58.3	2.75	0.38	0.49	0.6	55.1	3.1	0.38	0.5	0.62	51.5	3.5	0.37	0.5	0.64

8.5 TON COOLING STANDARD EFFICIENCY KHA102S4 (2ND STAGE) - SINGLE ZONE VAV SUPPLY FAN SUPPLY AIR BLOWER

Entering Wet Bulb Temperature	Total Air Volume	Outdoor Air Temperature Entering Outdoor Coil																			
		85°F					95°F					105°F					115°F				
		Total Cool Cap.	Comp. Motor Input	Sensible To Total Ratio (S/T)			Total Cool Cap.	Comp. Motor Input	Sensible To Total Ratio (S/T)			Total Cool Cap.	Comp. Motor Input	Sensible To Total Ratio (S/T)			Total Cool Cap.	Comp. Motor Input	Sensible To Total Ratio (S/T)		
				Dry Bulb					Dry Bulb					Dry Bulb					Dry Bulb		
		cfm	kBtuh	kW	75°F	80°F	85°F	kBtuh	kW	75°F	80°F	85°F	kBtuh	kW	75°F	80°F	85°F	kBtuh	kW	75°F	80°F
63°F	2720	98.8	6.36	0.71	0.87	1	92.4	7.2	0.73	0.89	1	85.6	8.16	0.74	0.92	1	78.4	9.32	0.77	0.97	1
	3400	103.8	6.38	0.77	0.95	1	97.2	7.21	0.8	0.99	1	90.4	8.18	0.82	1	1	83.5	9.31	0.86	1	1
	4080	108.4	6.4	0.84	1	1	102.1	7.23	0.86	1	1	95.7	8.2	0.9	1	1	88.4	9.34	0.94	1	1
67°F	2720	105.5	6.39	0.56	0.69	0.83	98.9	7.22	0.56	0.71	0.85	91.4	8.18	0.57	0.72	0.89	83.8	9.32	0.58	0.75	0.93
	3400	110.5	6.41	0.6	0.75	0.92	103.4	7.23	0.61	0.77	0.95	95.6	8.2	0.61	0.8	0.99	87.2	9.33	0.63	0.83	1
	4080	113.8	6.41	0.63	0.82	0.99	106.6	7.24	0.64	0.84	1	98.5	8.21	0.66	0.88	1	89.8	9.32	0.68	0.92	1
71°F	2720	112.4	6.41	0.42	0.55	0.67	105.2	7.24	0.42	0.55	0.69	97.7	8.19	0.41	0.56	0.7	89.7	9.34	0.41	0.57	0.73
	3400	117.5	6.43	0.44	0.59	0.73	110.2	7.26	0.44	0.6	0.75	102	8.22	0.43	0.61	0.78	93.4	9.34	0.43	0.62	0.81
	4080	121	6.44	0.45	0.62	0.79	113.4	7.27	0.45	0.64	0.82	105.2	8.23	0.46	0.66	0.85	95.8	9.34	0.46	0.67	0.89

8.5 TON HEATING STANDARD EFFICIENCY KHA102S4 - SINGLE ZONE VAV SUPPLY FAN SUPPLY AIR BLOWER

Indoor Coil Air Volume 70°F Dry Bulb cfm	Air Temperature Entering Outdoor Coil									
	65°F		45°F		25°F		5°F		-15°F	
	Total Heating Capacity	Comp. Motor Input	Total Heating Capacity	Comp. Motor Input	Total Heating Capacity	Comp. Motor Input	Total Heating Capacity	Comp. Motor Input	Total Heating Capacity	Comp. Motor Input
	kBtuh	kW	kBtuh	kW	kBtuh	kW	kBtuh	kW	kBtuh	kW
2720	124.0	7.58	93.6	6.91	62.2	6.24	40.0	5.44	20.1	4120
3400	126.0	7.09	95.6	6.43	64.1	5.75	41.9	4.95	22.1	3635
4080	128.0	6.79	97.6	6.12	66.2	5.44	43.9	4.64	24.1	3325

RATINGS

NOTE – For Temperatures and Capacities not shown in tables, see bulletin – Cooling Unit Rating Table Correction Factor Data in Miscellaneous Engineering Data section.

10 TON COOLING STANDARD EFFICIENCY KHA120S4 (1ST STAGE) - SINGLE ZONE VAV SUPPLY FAN SUPPLY AIR BLOWER

Entering Wet Bulb Temperature	Total Air Volume	Outdoor Air Temperature Entering Outdoor Coil																			
		65°F					75°F					85°F					95°F				
		Total Cool Cap.	Comp. Motor Input	Sensible To Total Ratio (S/T) Dry Bulb			Total Cool Cap.	Comp. Motor Input	Sensible To Total Ratio (S/T) Dry Bulb			Total Cool Cap.	Comp. Motor Input	Sensible To Total Ratio (S/T) Dry Bulb			Total Cool Cap.	Comp. Motor Input	Sensible To Total Ratio (S/T) Dry Bulb		
				75°F	80°F	85°F			75°F	80°F	85°F			75°F	80°F	85°F			75°F	80°F	85°F
cfm	kBtuh	kW	75°F	80°F	85°F	kBtuh	kW	75°F	80°F	85°F	kBtuh	kW	75°F	80°F	85°F	kBtuh	kW	75°F	80°F	85°F	
63°F	2240	58.1	2.82	0.61	0.72	0.83	55	3.21	0.61	0.73	0.84	51.8	3.65	0.62	0.74	0.86	48.2	4.13	0.62	0.75	0.88
	2800	62.4	2.85	0.64	0.77	0.9	59.1	3.25	0.65	0.78	0.92	55.5	3.68	0.65	0.8	0.94	51.6	4.16	0.66	0.82	0.97
	3360	65.6	2.88	0.68	0.82	0.96	62.1	3.27	0.69	0.84	0.98	58.2	3.7	0.7	0.86	1	54.2	4.18	0.71	0.88	1
67°F	2240	62.4	2.85	0.5	0.59	0.69	59.1	3.24	0.49	0.59	0.69	55.7	3.68	0.49	0.59	0.7	52	4.17	0.48	0.59	0.71
	2800	66.9	2.88	0.52	0.62	0.74	63.3	3.28	0.52	0.62	0.75	59.6	3.71	0.51	0.63	0.76	55.6	4.2	0.51	0.64	0.78
	3360	70.1	2.91	0.53	0.65	0.79	66.3	3.31	0.53	0.66	0.8	62.4	3.74	0.53	0.67	0.82	58.2	4.23	0.54	0.69	0.84
71°F	2240	66.6	2.88	0.39	0.48	0.57	63.3	3.28	0.39	0.48	0.57	59.6	3.71	0.38	0.47	0.57	55.9	4.2	0.37	0.47	0.57
	2800	71.3	2.92	0.4	0.5	0.6	67.6	3.32	0.4	0.5	0.6	63.5	3.75	0.39	0.5	0.61	59.6	4.24	0.38	0.5	0.61
	3360	74.6	2.94	0.41	0.52	0.63	70.7	3.34	0.4	0.52	0.64	66.6	3.78	0.4	0.52	0.65	62.2	4.27	0.39	0.53	0.66

10 TON COOLING STANDARD EFFICIENCY KHA120S4 (2ND STAGE) - SINGLE ZONE VAV SUPPLY FAN SUPPLY AIR BLOWER

Entering Wet Bulb Temperature	Total Air Volume	Outdoor Air Temperature Entering Outdoor Coil																			
		85°F					95°F					105°F					115°F				
		Total Cool Cap.	Comp. Motor Input	Sensible To Total Ratio (S/T) Dry Bulb			Total Cool Cap.	Comp. Motor Input	Sensible To Total Ratio (S/T) Dry Bulb			Total Cool Cap.	Comp. Motor Input	Sensible To Total Ratio (S/T) Dry Bulb			Total Cool Cap.	Comp. Motor Input	Sensible To Total Ratio (S/T) Dry Bulb		
				75°F	80°F	85°F			75°F	80°F	85°F			75°F	80°F	85°F			75°F	80°F	85°F
cfm	kBtuh	kW	75°F	80°F	85°F	kBtuh	kW	75°F	80°F	85°F	kBtuh	kW	75°F	80°F	85°F	kBtuh	kW	75°F	80°F	85°F	
63°F	3200	117.9	7.41	0.7	0.85	0.99	110	8.38	0.71	0.87	1	101.4	9.49	0.73	0.9	1	92.3	10.78	0.75	0.94	1
	4000	124.8	7.47	0.76	0.93	1	116.4	8.44	0.78	0.96	1	107.2	9.55	0.8	0.99	1	98	10.83	0.83	1	1
	4800	130	7.52	0.82	1	1	121.5	8.49	0.84	1	1	113.1	9.61	0.87	1	1	104.1	10.89	0.91	1	1
67°F	3200	126.6	7.48	0.55	0.68	0.82	118.3	8.46	0.55	0.69	0.84	109.1	9.57	0.55	0.71	0.86	99.4	10.85	0.55	0.73	0.9
	4000	133.2	7.55	0.58	0.74	0.9	124	8.52	0.59	0.75	0.93	114.5	9.63	0.6	0.78	0.96	104.1	10.9	0.61	0.81	0.99
	4800	137.8	7.6	0.62	0.8	0.97	128.3	8.57	0.63	0.82	0.99	118.1	9.67	0.64	0.85	1	107.2	10.93	0.66	0.89	1
71°F	3200	135.1	7.57	0.41	0.54	0.66	126.5	8.55	0.4	0.54	0.67	116.9	9.66	0.4	0.54	0.69	106.7	10.91	0.39	0.55	0.7
	4000	141.8	7.64	0.43	0.57	0.72	132.2	8.61	0.41	0.58	0.73	122.7	9.72	0.42	0.59	0.76	111.9	10.99	0.41	0.6	0.79
	4800	146.7	7.69	0.44	0.61	0.78	136.8	8.67	0.44	0.62	0.8	126.5	9.77	0.44	0.63	0.84	115.3	11.02	0.44	0.65	0.86

10 TON HEATING STANDARD EFFICIENCY KHA120S4 - SINGLE ZONE VAV SUPPLY FAN SUPPLY AIR BLOWER

Indoor Coil Air Volume 70°F Dry Bulb cfm	Air Temperature Entering Outdoor Coil									
	65°F		45°F		25°F		5°F		-15°F	
	Total Heating Capacity	Comp. Motor Input	Total Heating Capacity	Comp. Motor Input	Total Heating Capacity	Comp. Motor Input	Total Heating Capacity	Comp. Motor Input	Total Heating Capacity	Comp. Motor Input
3200	141.7	9.39	109.6	8.57	76.1	7.74	52.6	6.77	25.4	5130
4000	144.9	8.77	112.9	7.95	79.4	7.12	55.9	6.15	28.7	4510
4800	148.1	8.37	116.1	7.55	82.6	6.72	59.0	5.74	31.9	4105

RATINGS

NOTE – For Temperatures and Capacities not shown in tables, see bulletin – Cooling Unit Rating Table Correction Factor Data in Miscellaneous Engineering Data section.

12.5 TON COOLING STANDARD EFFICIENCY KHA150S4 (1ST STAGE) - SINGLE ZONE VAV SUPPLY FAN SUPPLY AIR BLOWER

Entering Wet Bulb Temperature	Total Air Volume	Outdoor Air Temperature Entering Outdoor Coil																			
		65°F					75°F					85°F					95°F				
		Total Cool Cap.	Comp. Motor Input	Sensible To Total Ratio (S/T) Dry Bulb			Total Cool Cap.	Comp. Motor Input	Sensible To Total Ratio (S/T) Dry Bulb			Total Cool Cap.	Comp. Motor Input	Sensible To Total Ratio (S/T) Dry Bulb			Total Cool Cap.	Comp. Motor Input	Sensible To Total Ratio (S/T) Dry Bulb		
				75°F	80°F	85°F			75°F	80°F	85°F			75°F	80°F	85°F			75°F	80°F	85°F
cfm	kBtuh	kW	75°F	80°F	85°F	kBtuh	kW	75°F	80°F	85°F	kBtuh	kW	75°F	80°F	85°F	kBtuh	kW	75°F	80°F	85°F	
63°F	2560	67.8	3.46	0.59	0.7	0.82	64.1	3.87	0.59	0.71	0.83	60.1	4.31	0.59	0.71	0.85	55.6	4.79	0.59	0.72	0.87
	3200	73.1	3.48	0.62	0.76	0.89	69	3.88	0.62	0.76	0.91	64.9	4.32	0.63	0.78	0.93	60.1	4.8	0.63	0.8	0.96
	3840	77.2	3.49	0.66	0.81	0.96	73	3.89	0.66	0.83	0.98	68.3	4.32	0.67	0.84	1	63.4	4.8	0.68	0.87	1
67°F	2560	73.1	3.47	0.48	0.57	0.67	69.2	3.88	0.47	0.57	0.67	65.1	4.32	0.46	0.56	0.67	60.6	4.8	0.45	0.56	0.68
	3200	78.6	3.49	0.5	0.6	0.72	74.6	3.89	0.49	0.6	0.73	70	4.32	0.49	0.6	0.74	65.4	4.8	0.48	0.61	0.75
	3840	82.9	3.5	0.51	0.64	0.78	78.6	3.9	0.51	0.64	0.79	73.8	4.33	0.51	0.64	0.8	68.5	4.8	0.51	0.65	0.82
71°F	2560	78.6	3.49	0.38	0.46	0.55	74.6	3.89	0.37	0.46	0.54	70.3	4.32	0.36	0.45	0.54	65.7	4.8	0.34	0.44	0.54
	3200	84.3	3.51	0.39	0.48	0.58	80.2	3.9	0.38	0.48	0.58	75.4	4.33	0.37	0.48	0.58	70.6	4.81	0.36	0.47	0.58
	3840	88.6	3.52	0.39	0.5	0.61	84.2	3.91	0.39	0.5	0.61	79.3	4.33	0.38	0.5	0.62	74	4.81	0.37	0.5	0.63

12.5 TON COOLING STANDARD EFFICIENCY KHA150S4 (2ND STAGE) - SINGLE ZONE VAV SUPPLY FAN SUPPLY AIR BLOWER

Entering Wet Bulb Temperature	Total Air Volume	Outdoor Air Temperature Entering Outdoor Coil																			
		85°F					95°F					105°F					115°F				
		Total Cool Cap.	Comp. Motor Input	Sensible To Total Ratio (S/T) Dry Bulb			Total Cool Cap.	Comp. Motor Input	Sensible To Total Ratio (S/T) Dry Bulb			Total Cool Cap.	Comp. Motor Input	Sensible To Total Ratio (S/T) Dry Bulb			Total Cool Cap.	Comp. Motor Input	Sensible To Total Ratio (S/T) Dry Bulb		
				75°F	80°F	85°F			75°F	80°F	85°F			75°F	80°F	85°F			75°F	80°F	85°F
cfm	kBtuh	kW	75°F	80°F	85°F	kBtuh	kW	75°F	80°F	85°F	kBtuh	kW	75°F	80°F	85°F	kBtuh	kW	75°F	80°F	85°F	
63°F	3800	138.4	8.45	0.7	0.86	1	128.4	9.38	0.71	0.88	1	117.7	10.42	0.72	0.9	1	106.5	11.6	0.74	0.94	1
	4400	144	8.45	0.74	0.91	1	133.6	9.39	0.76	0.94	1	122.8	10.43	0.77	0.97	1	111.6	11.6	0.8	1	1
	5000	148.6	8.45	0.78	0.96	1	138.6	9.39	0.8	0.98	1	127.6	10.43	0.82	1	1	116.8	11.61	0.85	1	1
67°F	3800	149.2	8.46	0.54	0.68	0.82	138.7	9.39	0.54	0.69	0.84	128.2	10.43	0.54	0.7	0.86	116.2	11.6	0.54	0.72	0.89
	4400	155	8.47	0.57	0.72	0.87	144.3	9.39	0.57	0.73	0.89	132.8	10.42	0.57	0.75	0.93	120.4	11.59	0.58	0.77	0.96
	5000	159.6	8.47	0.59	0.76	0.92	148.7	9.39	0.59	0.77	0.95	136.9	10.43	0.6	0.8	0.98	124.6	11.62	0.61	0.82	1
71°F	3800	160.3	8.47	0.4	0.53	0.66	149.9	9.39	0.39	0.53	0.67	138.9	10.44	0.38	0.53	0.68	126.5	11.61	0.37	0.54	0.69
	4400	166.4	8.48	0.41	0.56	0.69	155.5	9.4	0.41	0.56	0.71	143.7	10.43	0.4	0.56	0.72	131.4	11.62	0.39	0.57	0.74
	5000	171	8.49	0.42	0.58	0.74	159.7	9.4	0.41	0.58	0.75	148.1	10.44	0.41	0.59	0.77	135.5	11.62	0.41	0.6	0.8

12.5 TON HEATING STANDARD EFFICIENCY KHA150S4 - SINGLE ZONE VAV SUPPLY FAN SUPPLY AIR BLOWER

Indoor Coil Air Volume 70°F Dry Bulb cfm	Air Temperature Entering Outdoor Coil									
	65°F		45°F		25°F		5°F		-15°F	
	Total Heating Capacity	Comp. Motor Input	Total Heating Capacity	Comp. Motor Input	Total Heating Capacity	Comp. Motor Input	Total Heating Capacity	Comp. Motor Input	Total Heating Capacity	Comp. Motor Input
3800	167.2	10.04	127.6	9.22	86.4	8.39	58.2	7.34	28.6	5465
4400	170.6	9.68	131.1	8.86	89.8	8.03	61.7	6.97	32.0	5100
5000	174.0	9.41	134.5	8.59	93.2	7.76	65.1	6.71	35.4	4835

BLOWER DATA

092 BELT DRIVE BLOWER – BASE UNIT

BLOWER TABLE INCLUDES RESISTANCE FOR BASE UNIT ONLY (NO HEAT SECTION) WITH DRY INDOOR COIL AND AIR FILTERS IN PLACE. FOR ALL UNITS ADD:

- 1 – Wet indoor coil air resistance of selected unit.
- 2 – Any factory installed options air resistance (heat section, economizer, etc.)
- 3 – Any field installed accessories air resistance (duct resistance, diffuser, etc.)

Then determine from blower table blower motor output required.

See page 24 for blower motors and drives.

See page 24 for wet coil and option/accessory air resistance data.

MINIMUM AIR VOLUME REQUIRED FOR USE WITH OPTIONAL ELECTRIC HEAT (Maximum Static Pressure - 2.0 in. w.g.)

7.5 kW, 15 kW, 22.5 kW, 30 kW and 45 kW - 2800 cfm

Total Air Volume cfm	Total Static Pressure – in. w.g.																										
	0.2		0.4		0.6		0.8		1.0		1.2		1.4		1.6		1.8		2		2.2		2.4		2.6		
	RPM	BHP	RPM	BHP	RPM	BHP	RPM	BHP	RPM	BHP	RPM	BHP	RPM	BHP	RPM	BHP	RPM	BHP	RPM	BHP	RPM	BHP	RPM	BHP	RPM	BHP	RPM
1750	583	0.09	627	0.06	673	0.09	723	0.06	777	0.45	834	0.82	892	1.13	943	1.28	990	1.38	1038	1.44	1084	1.60	1131	1.79	1179	2.25	
2000	593	0.11	636	0.07	682	0.10	731	0.22	784	0.60	840	0.96	898	1.26	948	1.38	996	1.47	1045	1.57	1092	1.71	1140	1.92	1188	2.32	
2250	604	0.15	645	0.11	690	0.15	739	0.39	790	0.74	846	1.08	901	1.34	953	1.48	1002	1.57	1052	1.70	1100	1.86	1149	2.09	1197	2.42	
2500	615	0.19	655	0.15	699	0.20	747	0.55	797	0.89	851	1.20	906	1.44	959	1.58	1009	1.68	1059	1.83	1108	2.01	1158	2.26	1206	2.52	
2750	626	0.23	666	0.19	709	0.37	755	0.71	805	1.03	858	1.32	912	1.55	966	1.70	1017	1.81	1067	1.97	1117	2.17	1166	2.44	1215	2.71	
3000	637	0.27	677	0.24	719	0.55	764	0.87	813	1.18	866	1.45	920	1.67	975	1.82	1026	1.96	1076	2.13	1126	2.35	1176	2.63	1225	2.92	
3250	650	0.31	688	0.43	730	0.73	775	1.04	823	1.34	875	1.60	930	1.81	985	1.97	1036	2.12	1086	2.31	1136	2.54	1186	2.83	1235	3.13	
3500	663	0.35	700	0.63	741	0.92	786	1.22	834	1.50	886	1.76	942	1.96	997	2.14	1048	2.31	1097	2.51	1147	2.75	1196	3.04	1245	3.35	
3750	676	0.57	714	0.84	754	1.12	798	1.41	846	1.68	899	1.93	956	2.14	1010	2.32	1060	2.51	1109	2.72	1158	2.98	1207	3.27	1255	3.58	

BLOWER DATA

102, 120, 150 BELT DRIVE BLOWER – BASE UNIT

BLOWER TABLE INCLUDES RESISTANCE FOR BASE UNIT ONLY (NO HEAT SECTION) WITH DRY INDOOR COIL AND AIR FILTERS IN PLACE. FOR ALL UNITS ADD:

- 1 – Wet indoor coil air resistance of selected unit.
- 2 – Any factory installed options air resistance (heat section, economizer, etc.)
- 3 – Any field installed accessories air resistance (duct resistance, diffuser, etc.)

Then determine from blower table blower motor output required.

See page 24 for blower motors and drives.

See page 24 for wet coil and option/accessory air resistance data.

MINIMUM AIR VOLUME REQUIRED FOR USE WITH OPTIONAL ELECTRIC HEAT (Maximum Static Pressure - 2.0 in. w.g.)

15 kW, 22.5 kW, 30 kW and 45 kW - 2800 cfm

60 kW - 4000 cfm

Total Air Volume cfm	Total Static Pressure – in. w.g.																										
	0.2		0.4		0.6		0.8		1.0		1.2		1.4		1.6		1.8		2		2.2		2.4		2.6		
	RPM	BHP	RPM	BHP	RPM	BHP	RPM	BHP	RPM	BHP	RPM	BHP	RPM	BHP	RPM	BHP	RPM	BHP	RPM	BHP	RPM	BHP	RPM	BHP	RPM	BHP	RPM
1750	480	0.19	548	0.39	618	0.57	689	0.70	758	0.81	824	0.92	885	1.07	941	1.23	992	1.40	1039	1.55	1084	1.70	1128	1.85	1156	2.08	
2000	492	0.27	560	0.47	629	0.64	700	0.77	768	0.88	832	1.00	892	1.16	946	1.32	995	1.48	1041	1.65	1085	1.81	1127	1.97	1160	2.13	
2250	505	0.35	573	0.55	643	0.72	713	0.85	780	0.97	842	1.10	900	1.25	952	1.42	999	1.59	1044	1.76	1087	1.93	1127	2.10	1164	2.27	
2500	520	0.45	588	0.64	658	0.81	727	0.94	793	1.07	853	1.21	909	1.37	959	1.54	1005	1.71	1048	1.89	1089	2.07	1127	2.25	1166	2.42	
2750	536	0.55	604	0.74	674	0.91	743	1.05	806	1.19	865	1.34	919	1.50	968	1.67	1012	1.86	1053	2.04	1092	2.23	1129	2.41	1167	2.60	
3000	553	0.66	622	0.85	692	1.02	760	1.17	821	1.32	878	1.48	930	1.64	977	1.83	1020	2.02	1059	2.21	1096	2.41	1133	2.60	1170	2.79	
3250	572	0.77	641	0.98	712	1.15	778	1.32	837	1.48	892	1.64	942	1.81	988	2.00	1028	2.20	1066	2.41	1102	2.61	1138	2.81	1174	3.01	
3500	592	0.90	663	1.12	733	1.31	798	1.48	854	1.65	907	1.82	955	1.99	999	2.19	1038	2.41	1074	2.63	1109	2.84	1144	3.04	1180	3.24	
3750	614	1.04	687	1.28	756	1.48	818	1.66	872	1.83	922	2.01	969	2.19	1010	2.41	1048	2.64	1084	2.87	1118	3.09	1152	3.29	1188	3.50	
4000	639	1.22	712	1.47	780	1.67	838	1.85	890	2.03	939	2.22	983	2.42	1023	2.65	1060	2.90	1095	3.14	1128	3.36	1162	3.57	1198	3.77	
4250	666	1.42	740	1.68	804	1.88	859	2.06	909	2.25	956	2.45	998	2.67	1036	2.92	1072	3.18	1106	3.42	1139	3.65	1172	3.86	1208	4.07	
4500	697	1.65	769	1.91	829	2.10	881	2.28	929	2.48	973	2.71	1013	2.95	1050	3.22	1085	3.48	1118	3.73	1151	3.96	1184	4.17	1221	4.39	
4750	729	1.91	798	2.15	854	2.34	903	2.53	948	2.75	991	3.00	1030	3.27	1065	3.55	1099	3.81	1132	4.06	1164	4.29	1198	4.51	1235	4.74	
5000	763	2.18	826	2.41	878	2.60	925	2.81	968	3.05	1009	3.33	1046	3.61	1081	3.90	1114	4.17	1146	4.42	1178	4.65	1212	4.87	1250	5.09	
5250	797	2.47	854	2.69	903	2.90	947	3.12	989	3.39	1028	3.69	1064	3.99	1098	4.28	1130	4.55	1162	4.80	1194	5.02	1228	5.24	1266	5.47	
5500	830	2.78	882	3.00	927	3.22	969	3.48	1010	3.77	1047	4.09	1083	4.40	1116	4.69	1147	4.96	1179	5.20	1211	5.42	1246	5.63	---	---	
5750	861	3.11	908	3.34	951	3.58	992	3.87	1031	4.19	1068	4.52	1102	4.84	1134	5.12	1165	5.38	1196	5.61	---	---	---	---	---	---	
6000	890	3.45	935	3.71	976	3.98	1016	4.31	1053	4.65	1089	4.99	1122	5.30	1153	5.58	---	---	---	---	---	---	---	---	---	---	
6250	918	3.84	961	4.12	1001	4.43	1040	4.79	1076	5.14	1110	5.48	---	---	---	---	---	---	---	---	---	---	---	---	---	---	

BLOWER DATA

FACTORY INSTALLED BELT DRIVE KIT SPECIFICATIONS

Nominal hp	Maximum hp	Drive Kit Number	RPM Range
2	2.3	1	590 - 890
2	2.3	2	800 - 1105
2	2.3	3	795 - 1195
3	3.45	4	730 - 970
3	3.45	5	940 - 1200
3	3.45	6	1015 - 1300
5	5.75	10	900 - 1135
5	5.75	11	1040 - 1315
5	5.75	12	1125 - 1425

NOTE - Using total air volume and system static pressure requirements determine from blower performance tables rpm and motor output required. Maximum usable output of motors furnished are shown. In Canada, nominal motor output is also maximum usable motor output. If motors of comparable output are used, be sure to keep within the service factor limitations outlined on the motor nameplate.

NOTE – Units equipped with Single Zone VAV Supply Fan option are limited to a motor service factor of 1.0.

POWER EXHAUST FAN PERFORMANCE

Return Air System Static Pressure	Air Volume Exhausted
in. w.g.	cfm
0	3175
0.05	2955
0.10	2685
0.15	2410
0.20	2165
0.25	1920
0.30	1420
0.35	1200

FACTORY INSTALLED OPTIONS/FIELD INSTALLED ACCESSORY AIR RESISTANCE - in. w.g.

Air Volume cfm	Wet Indoor Coil		Electric Heat	Economizer	Filters	
	092	102, 120, 150			MERV 8	MERV 13
1750	0.03	0.04	0.03	0.05	0.01	0.03
2000	0.04	0.05	0.03	0.06	0.01	0.03
2250	0.05	0.06	0.04	0.08	0.01	0.04
2500	0.05	0.07	0.04	0.11	0.01	0.05
2750	0.06	0.08	0.05	0.12	0.02	0.05
3000	0.07	0.10	0.06	0.13	0.02	0.06
3250	0.08	0.11	0.06	0.15	0.02	0.06
3500	0.09	0.12	0.09	0.15	0.03	0.07
3750	0.10	0.14	0.09	0.15	0.03	0.08
4000	0.11	0.15	0.09	0.19	0.04	0.08
4250	0.13	0.17	0.13	0.19	0.04	0.09
4500	0.14	0.19	0.14	0.22	0.04	0.09
4750	0.15	0.20	0.17	0.25	0.05	0.10
5000	0.16	0.22	0.20	0.29	0.06	0.10
5250	0.17	0.24	0.22	0.32	0.06	0.11
5500	0.19	0.25	0.25	0.34	0.07	0.12
5750	0.20	0.27	0.31	0.45	0.07	0.12
6000	0.22	0.29	0.33	0.52	0.08	0.13

BLOWER DATA

CEILING DIFFUSERS AIR RESISTANCE - in. w.g.

Unit Size	RTD11 Step-Down Diffuser			FD11 Flush Diffuser	
	Air Volume cfm	2 Ends Open	1 Side, 2 Ends Open		All Ends & Sides Open
092 Models	2400	0.21	0.18	0.15	0.14
	2600	0.24	0.21	0.18	0.17
	2800	0.27	0.24	0.21	0.20
	3000	0.32	0.29	0.25	0.25
	3200	0.41	0.37	0.32	0.31
	3400	0.50	0.45	0.39	0.37
	3600	0.61	0.54	0.48	0.44
102 & 120 Models	3800	0.73	0.63	0.57	0.51
	3600	0.36	0.28	0.23	0.15
	3800	0.40	0.32	0.26	0.18
	4000	0.44	0.36	0.29	0.21
	4200	0.49	0.40	0.33	0.24
	4400	0.54	0.44	0.37	0.27
	4600	0.60	0.49	0.42	0.31
	4800	0.65	0.53	0.46	0.35
150 Models	5000	0.69	0.58	0.50	0.39
	5200	0.75	0.62	0.54	0.43
	4200	0.22	0.19	0.16	0.10
	4400	0.28	0.24	0.20	0.12
	4600	0.34	0.29	0.24	0.15
	4800	0.40	0.34	0.29	0.19
	5000	0.46	0.39	0.34	0.23
	5200	0.52	0.44	0.39	0.27
	5400	0.58	0.49	0.43	0.31
5600	0.64	0.54	0.47	0.35	
5800	0.70	0.59	0.51	0.39	

CEILING DIFFUSER AIR THROW DATA

Model No.	Air Volume cfm	¹ Effective Throw Range	
		RTD11 Step-Down	FD11 Flush
		ft.	ft.
092 Models	2600	24 - 29	19 - 24
	2800	25 - 30	20 - 28
	3000	27 - 33	21 - 29
	3200	28 - 35	22 - 29
	3400	30 - 37	22 - 30
102, 120 Models	3600	25 - 33	22 - 29
	3800	27 - 35	22 - 30
	4000	29 - 37	24 - 33
	4200	32 - 40	26 - 35
	4400	34 - 42	28 - 37
150 Models	5600	39 - 49	28 - 37
	5800	42 - 51	29 - 38
	6000	44 - 54	40 - 50
	6200	45 - 55	42 - 51
	6400	46 - 55	43 - 52
6600	47 - 56	45 - 56	

¹ Throw is the horizontal or vertical distance an air stream travels on leaving the outlet or diffuser before the maximum velocity is reduced to 50 ft. per minute. Four sides open.

ELECTRICAL/ELECTRIC HEAT DATA

7.5 TON

7.5 TON STANDARD EFFICIENCY (R-410A)

KHA092S4

¹ Voltage - 60hz		208/230V - 3 Ph			460V - 3 Ph			575V - 3 Ph		
Compressor 1	Rated Load Amps	13.1			6.1			4.4		
	Locked Rotor Amps	83.1			41			33		
Compressor 2	Rated Load Amps	13.1			6.1			4.4		
	Locked Rotor Amps	83.1			41			33		
Outdoor Fan Motors (2)	Full Load Amps	2.4			1.3			1		
	(total)	(4.8)			(2.6)			(2)		
Power Exhaust (1) 0.33 HP	Full Load Amps	2.4			1.3			1		
Service Outlet 115V GFI (amps)		15			15			20		
Indoor Blower Motor	Horsepower	2	3	5	2	3	5	2	3	5
	Full Load Amps	7.5	10.6	16.7	3.4	4.8	7.6	2.7	3.9	6.1
² Maximum Overcurrent Protection	Unit Only	50	50	60	25	25	30	15	20	20
	With (1) 0.33 HP Power Exhaust	50	60	70	25	25	30	20	20	25
³ Minimum Circuit Ampacity	Unit Only	42	45	52	20	22	25	15	16	19
	With (1) 0.33 HP Power Exhaust	45	48	55	22	23	26	16	17	20

ELECTRIC HEAT DATA

Electric Heat Voltage			208V	240V	208V	240V	208V	240V	480V	480V	480V	600V	600V	600V
² Maximum Overcurrent Protection	Unit+ Electric Heat	7.5 kW	70	70	70	70	80	80	35	35	40	25	25	30
		15 kW	90	90	90	90	100	100	45	45	50	35	35	40
		22.5 kW	110	110	110	125	125	125	60	60	60	45	45	50
		30 kW	125	150	125	150	150	150	70	70	70	60	60	60
		45 kW	175	200	175	200	175	200	90	90	100	70	70	80
³ Minimum Circuit Ampacity	Unit+ Electric Heat	7.5 kW	62	65	65	68	72	75	32	33	36	24	25	28
		15 kW	81	87	84	90	91	97	43	44	47	33	34	37
		22.5 kW	101	110	104	113	111	120	54	55	59	42	43	46
		30 kW	120	132	124	136	131	143	65	67	70	51	52	55
		45 kW	160	178	163	181	170	188	88	89	92	69	70	73
² Maximum Overcurrent Protection	Unit+ Electric Heat and (1) 0.33 HP Power Exhaust	7.5 kW	70	70	70	70	80	80	35	35	40	25	30	30
		15 kW	90	90	90	100	100	100	45	45	50	35	35	40
		22.5 kW	110	125	110	125	125	125	60	60	60	45	45	50
		30 kW	125	150	150	150	150	150	70	70	80	60	60	60
		45 kW	175	200	175	200	175	200	90	100	100	70	80	80
³ Minimum Circuit Ampacity	Unit+ Electric Heat and (1) 0.33 HP Power Exhaust	7.5 kW	64	67	67	70	74	77	33	34	37	25	26	29
		15 kW	84	90	87	93	94	100	44	45	49	34	35	38
		22.5 kW	103	112	106	115	113	122	55	57	60	43	44	47
		30 kW	123	135	126	138	133	145	67	68	71	52	53	56
		45 kW	162	180	165	183	172	190	89	91	94	70	71	74

ELECTRICAL ACCESSORIES

Disconnect	7.5 kW	15 kW	22.5 kW	30 kW	45 kW
	54W56	54W56	54W56	54W56	54W56
	54W57	54W56	54W56	54W56	54W56
	54W57	54W56	54W56	54W56	54W56
	54W57	54W56	54W56	54W56	54W56
	Not Available	54W57	54W56	54W56	54W56

NOTE - All units have a minimum Short Circuit Current Rating (SCCR) of 5000 amps.

¹ Extremes of operating range are plus and minus 10% of line voltage.

² HACR type breaker or fuse.

³ Refer to National or Canadian Electrical Code manual to determine wire, fuse and disconnect size requirements.

ELECTRICAL/ELECTRIC HEAT DATA**8.5 TON****8.5 TON STANDARD EFFICIENCY (R-410A)****KHA102S4**

¹ Voltage - 60hz		208/230V - 3 Ph			460V - 3 Ph			575V - 3 Ph		
Compressor 1	Rated Load Amps	14.5			6.3			6		
	Locked Rotor Amps	98			55			41		
Compressor 2	Rated Load Amps	14.5			6.3			6		
	Locked Rotor Amps	98			55			41		
Outdoor Fan Motors (2)	Full Load Amps	3			1.5			1.2		
	(total)	(6)			(3)			(2.4)		
Power Exhaust (1) 0.33 HP	Full Load Amps	2.4			1.3			1		
Service Outlet 115V GFI (amps)		15			15			20		
Indoor Blower Motor	Horsepower	2	3	5	2	3	5	2	3	5
	Full Load Amps	7.5	10.6	16.7	3.4	4.8	7.6	2.7	3.9	6.1
² Maximum Overcurrent Protection	Unit Only	60	60	70	25	25	30	20	25	25
	With (1) 0.33 HP Power Exhaust	60	60	70	25	25	30	25	25	25
³ Minimum Circuit Ampacity	Unit Only	47	50	56	21	22	26	19	20	23
	With (1) 0.33 HP Power Exhaust	49	52	59	22	24	27	20	21	24

ELECTRIC HEAT DATA

Electric Heat Voltage			208V	240V	208V	240V	208V	240V	480V	480V	480V	600V	600V	600V
² Maximum Overcurrent Protection	Unit+ Electric Heat	7.5 kW	70	70	70	80	80	90	35	35	40	30	30	35
		15 kW	90	100	90	100	100	110	45	45	50	40	40	45
		22.5 kW	110	125	110	125	125	125	60	60	60	50	50	50
		30 kW	125	150	150	150	150	150	70	70	80	60	60	60
		45 kW	175	200	175	200	175	200	90	90	100	80	80	80
³ Minimum Circuit Ampacity	Unit+ Electric Heat	7.5 kW	66	69	69	72	76	79	32	34	37	28	29	32
		15 kW	86	92	89	95	95	101	44	45	48	37	38	41
		22.5 kW	105	114	108	117	115	124	55	56	59	46	47	50
		30 kW	125	137	128	140	135	147	66	68	71	55	56	59
		45 kW	164	182	167	185	174	192	89	90	93	73	74	77
² Maximum Overcurrent Protection	Unit+ Electric Heat and (1) 0.33 HP Power Exhaust	7.5 kW	70	80	80	80	90	90	35	35	40	30	30	35
		15 kW	90	100	100	100	100	110	45	50	50	40	40	45
		22.5 kW	110	125	125	125	125	150	60	60	70	50	50	60
		30 kW	150	150	150	150	150	150	70	70	80	60	60	60
		45 kW	175	200	175	200	200	200	90	100	100	80	80	80
³ Minimum Circuit Ampacity	Unit+ Electric Heat and (1) 0.33 HP Power Exhaust	7.5 kW	69	72	72	75	78	81	34	35	38	29	30	33
		15 kW	88	94	91	97	98	104	45	46	49	38	39	42
		22.5 kW	108	117	111	120	117	126	56	58	61	47	48	51
		30 kW	127	139	130	142	137	149	67	69	72	56	57	60
		45 kW	166	184	169	187	176	194	90	91	95	74	75	78

ELECTRICAL ACCESSORIES

Disconnect	7.5 kW	54W56	54W56	54W56
	15 kW	54W57	54W56	54W56
	22.5 kW	54W57	54W56	54W56
	30 kW	54W57	54W56	54W56
	45 kW	Not Available	54W57	54W56

NOTE - All units have a minimum Short Circuit Current Rating (SCCR) of 5000 amps.

¹ Extremes of operating range are plus and minus 10% of line voltage.² HACR type breaker or fuse.³ Refer to National or Canadian Electrical Code manual to determine wire, fuse and disconnect size requirements.

ELECTRICAL/ELECTRIC HEAT DATA

10 TON

10 TON STANDARD EFFICIENCY (R-410A)

KHA120S4

¹ Voltage - 60hz		208/230V - 3 Ph			460V - 3 Ph			575V - 3 Ph		
Compressor 1	Rated Load Amps	15.6			7.8			5.8		
	Locked Rotor Amps	110			52			38.9		
Compressor 2	Rated Load Amps	15.6			7.8			5.8		
	Locked Rotor Amps	110			52			38.9		
Outdoor Fan Motors (2)	Full Load Amps	3			1.5			1.2		
	(total)	(6)			(3)			(2.4)		
Power Exhaust (1) 0.33 HP	Full Load Amps	2.4			1.3			1		
Service Outlet 115V GFI (amps)		15			15			20		
Indoor Blower Motor	Horsepower	2	3	5	2	3	5	2	3	5
	Full Load Amps	7.5	10.6	16.7	3.4	4.8	7.6	2.7	3.9	6.1
² Maximum Overcurrent Protection	Unit Only	60	60	70	30	30	35	20	25	25
	With (1) 0.33 HP Power Exhaust	60	60	70	30	30	35	20	25	25
³ Minimum Circuit Ampacity	Unit Only	49	52	59	24	26	29	19	20	22
	With (1) 0.33 HP Power Exhaust	51	55	61	26	27	30	20	21	23

ELECTRIC HEAT DATA

Electric Heat Voltage			208V	240V	208V	240V	208V	240V	480V	480V	480V	600V	600V	600V
² Maximum Overcurrent Protection	Unit+ Electric Heat	15 kW	90	100	100	100	100	110	50	50	60	40	40	40
		22.5 kW	110	125	125	125	125	150	60	60	70	50	50	50
		30 kW	150	150	150	150	150	150	70	80	80	60	60	60
		45 kW	175	200	175	200	200	200	100	100	100	80	80	80
		60 kW	175	200	200	200	200	225	100	100	110	80	80	80
³ Minimum Circuit Ampacity	Unit+ Electric Heat	15 kW	88	94	91	97	98	104	47	48	51	37	38	40
		22.5 kW	108	117	111	120	117	126	58	60	62	46	47	49
		30 kW	127	139	130	142	137	149	70	71	74	55	56	58
		45 kW	166	184	169	188	176	194	92	94	96	73	74	76
		60 kW	174	193	177	197	184	203	97	98	101	76	78	80
² Maximum Overcurrent Protection	Unit+ Electric Heat and (1) 0.33 HP Power Exhaust	15 kW	100	100	100	100	100	110	50	50	60	40	40	45
		22.5 kW	110	125	125	125	125	150	60	70	70	50	50	50
		30 kW	150	150	150	150	150	175	80	80	80	60	60	60
		45 kW	175	200	175	200	200	200	100	100	100	80	80	80
		60 kW	200	200	200	200	200	225	100	100	110	80	80	90
³ Minimum Circuit Ampacity	Unit+ Electric Heat and (1) 0.33 HP Power Exhaust	15 kW	91	97	94	100	100	106	48	50	53	38	39	41
		22.5 kW	110	119	113	122	120	129	60	61	64	47	48	50
		30 kW	130	142	133	145	139	151	71	72	75	56	57	59
		45 kW	169	187	172	190	178	196	93	95	98	74	75	77
		60 kW	177	196	180	199	186	205	98	99	102	77	79	81

ELECTRICAL ACCESSORIES

Disconnect	15 kW	54W57			54W56			54W56		
	22.5 kW	54W57			54W56			54W56		
	30 kW	54W57			54W56			54W56		
	45 kW	Not Available			54W57			54W56		
	60 kW	Not Available			54W57			54W56		

NOTE - All units have a minimum Short Circuit Current Rating (SCCR) of 5000 amps.

¹ Extremes of operating range are plus and minus 10% of line voltage.

² HACR type breaker or fuse.

³ Refer to National or Canadian Electrical Code manual to determine wire, fuse and disconnect size requirements.

ELECTRICAL/ELECTRIC HEAT DATA

12.5 TON

12.5 TON STANDARD EFFICIENCY (R-410A)

KHA150S4

¹ Voltage - 60hz		208/230V - 3 Ph			460V - 3 Ph			575V - 3 Ph		
Compressor 1	Rated Load Amps	19			9.7			7.4		
	Locked Rotor Amps	123			62			50		
Compressor 2	Rated Load Amps	19			9.7			7.4		
	Locked Rotor Amps	123			62			50		
Outdoor Fan Motors (2)	Full Load Amps	2.4			1.3			1		
	(total)	(7.2)			(3.9)			(3)		
Power Exhaust (1) 0.33 HP	Full Load Amps	2.4			1.3			1		
Service Outlet 115V GFI (amps)		15			15			20		
Indoor Blower Motor	Horsepower	2	3	5	2	3	5	2	3	5
	Full Load Amps	7.5	10.6	16.7	3.4	4.8	7.6	2.7	3.9	6.1
² Maximum Overcurrent Protection	Unit Only	70	70	80	35	40	40	25	30	30
	With (1) 0.33 HP Power Exhaust	70	80	80	40	40	40	30	30	30
³ Minimum Circuit Ampacity	Unit Only	58	61	67	30	31	34	23	24	26
	With (1) 0.33 HP Power Exhaust	60	63	70	31	32	35	24	25	27

ELECTRIC HEAT DATA

Electric Heat Voltage			208V	240V	208V	240V	208V	240V	480V	480V	480V	600V	600V	600V
² Maximum Overcurrent Protection	Unit+ Electric Heat	15 kW	100	110	110	110	110	125	60	60	60	45	45	45
		22.5 kW	125	150	125	150	150	150	70	70	70	50	60	60
		30 kW	150	150	150	175	150	175	80	80	80	60	60	70
		45 kW	175	200	200	200	200	225	100	100	110	80	80	80
		60 kW	200	225	200	225	200	225	110	110	110	90	90	90
³ Minimum Circuit Ampacity	Unit+ Electric Heat	15 kW	97	103	100	106	106	112	52	54	56	41	42	44
		22.5 kW	117	126	120	129	126	135	63	65	68	50	51	53
		30 kW	136	148	139	151	145	157	75	76	79	59	60	62
		45 kW	175	193	178	196	184	202	97	99	101	77	78	80
		60 kW	183	202	186	205	192	211	102	103	106	81	82	84
² Maximum Overcurrent Protection	Unit+ Electric Heat and (1) 0.33 HP Power Exhaust	15 kW	110	110	110	110	110	125	60	60	60	45	45	45
		22.5 kW	125	150	125	150	150	150	70	70	70	60	60	60
		30 kW	150	175	150	175	150	175	80	80	80	60	70	70
		45 kW	200	200	200	200	200	225	100	100	110	80	80	90
		60 kW	200	225	200	225	200	225	110	110	110	90	90	90
³ Minimum Circuit Ampacity	Unit+ Electric Heat and (1) 0.33 HP Power Exhaust	15 kW	99	105	103	109	109	115	53	55	58	42	43	45
		22.5 kW	119	128	122	131	128	137	65	66	69	51	52	54
		30 kW	139	151	142	154	148	160	76	77	80	60	61	63
		45 kW	178	196	181	199	187	205	99	100	103	78	79	81
		60 kW	185	205	189	208	195	214	103	104	107	82	83	85

ELECTRICAL ACCESSORIES

Disconnect		15 kW	54W57	54W56	54W56
		22.5 kW	54W57	54W56	54W56
		30 kW	Not Available	54W56	54W56
		45 kW	Not Available	54W57	54W57
		60 kW	Not Available	54W57	54W57

NOTE - All units have a minimum Short Circuit Current Rating (SCCR) of 5000 amps.

¹ Extremes of operating range are plus and minus 10% of line voltage.

² HACR type breaker or fuse.

³ Refer to National or Canadian Electrical Code manual to determine wire, fuse and disconnect size requirements.

ELECTRIC HEAT CAPACITIES

Volts Input	7.5 kW			15 kW			22.5 kW			30 kW			45 kW			60 kW		
	kW Input	Btuh Output	No. of Stages	kW Input	Btuh Output	No. of Stages	kW Input	Btuh Output	No. of Stages	kW Input	Btuh Output	No. of Stages	kW Input	Btuh Output	No. of Stages	kW Input	Btuh Output	No. of Stages
208	5.6	19,100	1	11.3	38,600	1	16.9	57,700	2	22.5	76,800	2	33.8	115,300	2	45.0	153,600	2
220	6.3	21,500	1	12.6	43,000	1	18.9	64,500	2	25.2	86,000	2	37.8	129,000	2	50.4	172,000	2
230	6.9	23,600	1	13.8	47,100	1	20.7	70,700	2	27.5	93,900	2	41.3	141,000	2	55.1	188,000	2
240	7.5	25,600	1	15.0	51,200	1	22.5	76,800	2	30.0	102,400	2	45.0	153,600	2	60.0	204,800	2
440	6.9	21,500	1	12.6	43,000	1	18.9	64,500	2	25.2	86,000	2	37.8	129,000	2	50.4	172,000	2
460	6.9	23,600	1	13.8	47,100	1	20.7	70,700	2	27.5	93,900	2	41.3	141,000	2	55.1	188,000	2
480	7.5	25,600	1	15.0	51,200	1	22.5	76,800	2	30.0	102,400	2	45.0	153,600	2	60.0	204,800	2
550	6.3	21,500	1	12.6	43,000	1	18.9	64,500	2	25.2	86,000	2	37.8	129,000	2	50.4	172,000	2
575	6.9	23,600	1	13.8	47,100	1	20.7	70,700	2	27.5	93,900	2	41.3	141,000	2	55.1	188,000	2
600	7.5	25,600	1	15.0	51,200	1	22.5	76,800	2	30.0	102,400	2	45.0	153,600	2	60.0	204,800	2

UNIT CLEARANCES - INCHES (MM)

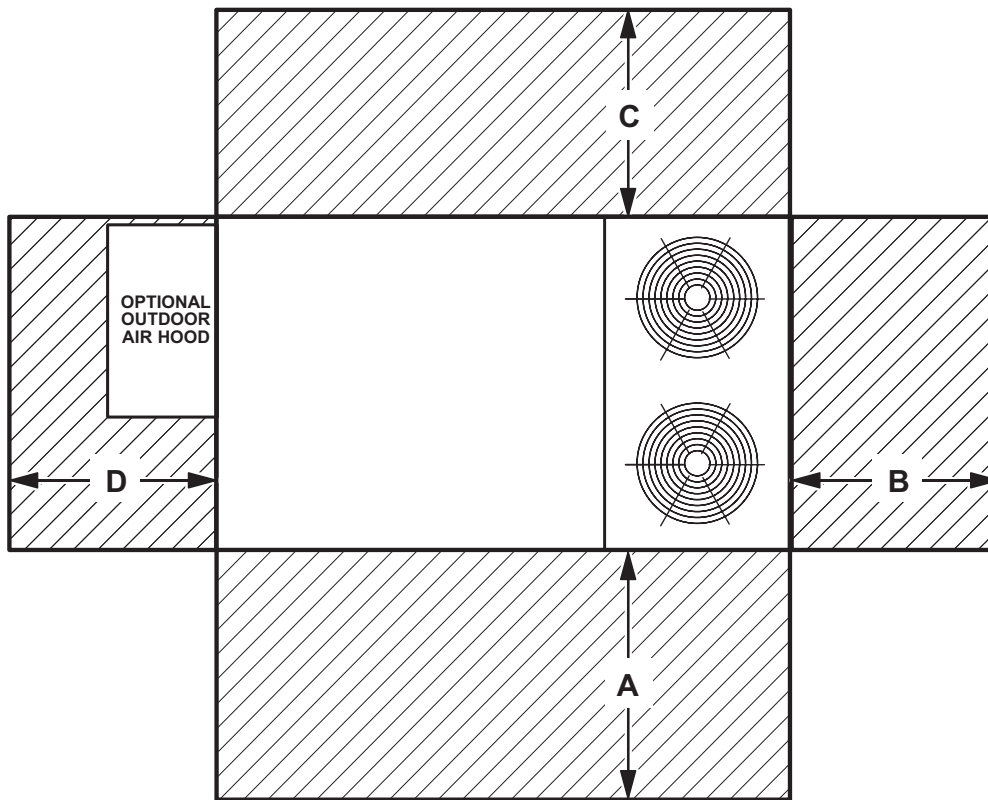

¹ Unit Clearance	A		B		C		D		Top Clearance
	in.	mm	in.	mm	in.	mm	in.	mm	
Service Clearance	60	1524	36	914	36	914	60	1524	Unobstructed
Minimum Operation Clearance	36	914	36	914	36	914	36	914	

NOTE - Entire perimeter of unit base requires support when elevated above the mounting surface.

¹ **Service Clearance** - Required for removal of serviceable parts.

Minimum Operation Clearance - Required clearance for proper unit operation.

OUTDOOR SOUND DATA

Unit Model Number	Octave Band Linear Sound Power Levels dBA, re 10 ⁻¹² Watts Center Frequency - Hz							¹ Sound Rating Number (SRN) (dBA)
	125	250	500	1000	2000	4000	8000	
092, 102 and 120	76	79	84	83	79	73	66	88
150	77	80	85	84	79	74	66	88

Note - The octave sound power data does not include tonal corrections.

¹ Sound Rating Number according to ARI Standard 270-95 or ARI Standard 370-2001 (includes pure tone penalty). "SRN" is the overall A-Weighted Sound Power Level, (Lwa), dB (100 Hz to 10,000 Hz).

THIS PAGE INTENTIONALLY BLANK

WEIGHT DATA

Model Number	Net		Shipping	
	lbs.	kg	lbs.	kg
092 Base Unit	1052	477	1137	516
092 Max. Unit	1209	548	1294	587
102 Base Unit	1084	492	1169	530
102 Max. Unit	1241	563	1326	601
120 Base Unit	1150	522	1235	560
120 Max. Unit	1314	596	1399	635
150 Base Unit	1350	612	1435	651
150 Max. Unit	1514	687	1599	725

OPTIONS / ACCESSORIES

Model Number	Shipping Weight	
	lbs.	kg
ECONOMIZER / OUTDOOR AIR / EXHAUST		
Economizer		
Economizer Dampers	60	27
Barometric Relief Dampers (downflow)	8	4
Barometric Relief Damper Hood (downflow)	25	11
Outdoor Air Hood (downflow)	23	10
Outdoor Air Dampers		
Outdoor Air Damper Section - Automatic	51	23
Outdoor Air Damper Section - Manual	39	18
Power Exhaust	31	14
ELECTRIC HEAT		
7.5 kW	50	23
15 kW	50	23
22.5 kW	57	26
30 kW	57	26
45 kW	59	27
60 kW	68	31
SINGLE ZONE VAV SUPPLY FAN SUPPLY AIR BLOWER OPTION		
Variable Frequency Drive (VFD) and associated components	10	5
ROOF CURBS		
Hybrid Roof Curbs, Downflow		
8 in. height	60	27
14 in. height	85	39
18 in. height	100	45
24 in. height	125	57
Adjustable Pitch Curb, Downflow		
14 in. height	191	82
PACKAGING		
LTL Packaging (less than truck load)	105	48
CEILING DIFFUSERS		
Step-Down		
RTD11-95	88	40
RTD11-135	205	93
RTD11-185	392	178
Flush		
FD11-95	75	34
FD11-135	174	79
FD11-185	289	131
Transitions		
C1DIFF30B-1	30	14
C1DIFF31B-1	32	15
C1DIFF32B-1	36	16

DIMENSIONS - UNIT - INCHES (MM) - 092-102-120 MODELS

Model No.	CORNER WEIGHTS														CENTER OF GRAVITY									
	AA				BB				CC				DD				EE				FF			
	Base		Max.		Base		Max.		Base		Max.		Base		Max.		Base		Max.		Base		Max.	
	lbs.	kg	lbs.	kg	lbs.	kg	lbs.	kg	lbs.	kg	lbs.	kg	lbs.	kg	lbs.	kg	in.	mm	in.	mm	in.	mm	in.	mm
092	264	120	310	140	237	108	271	123	258	117	290	131	293	133	339	154	46.5	1181	45.5	1156	24.5	622	25.5	648
102	272	123	318	144	244	111	278	126	266	121	297	135	302	137	348	158	46.5	1181	45.5	1156	24.5	622	25.5	648
120	284	129	333	151	264	120	298	135	288	131	320	145	315	143	363	165	46.5	1181	45.5	1156	24.5	622	25.5	648

Base Unit - The unit with NO OPTIONS.

Max. Unit - The unit with ALL OPTIONS Installed (Economizer, etc.).

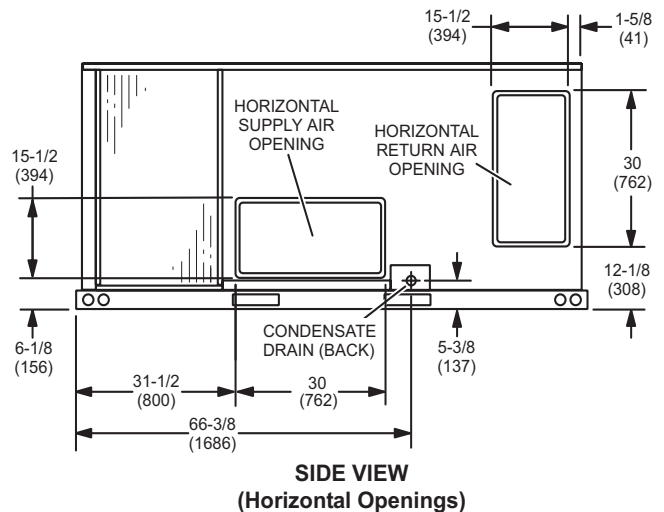
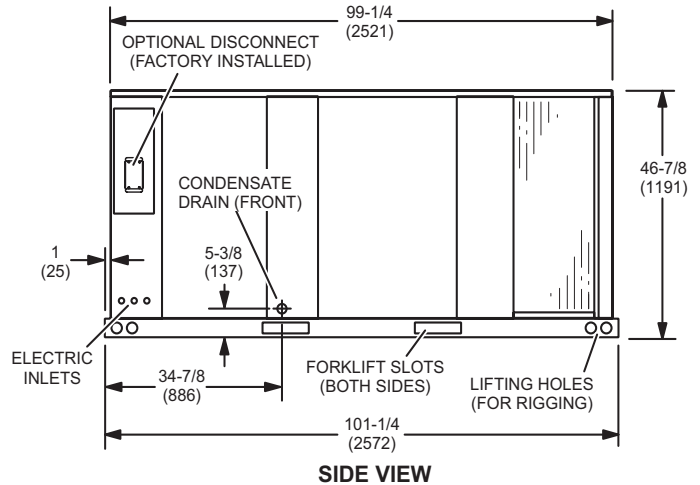
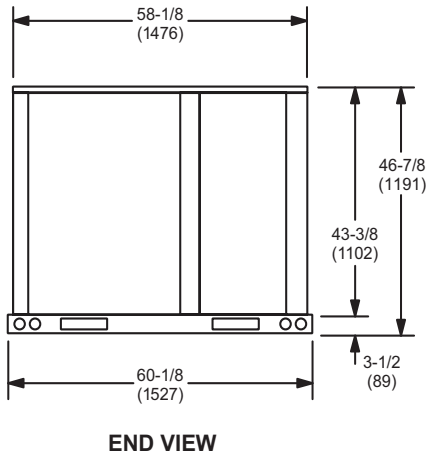
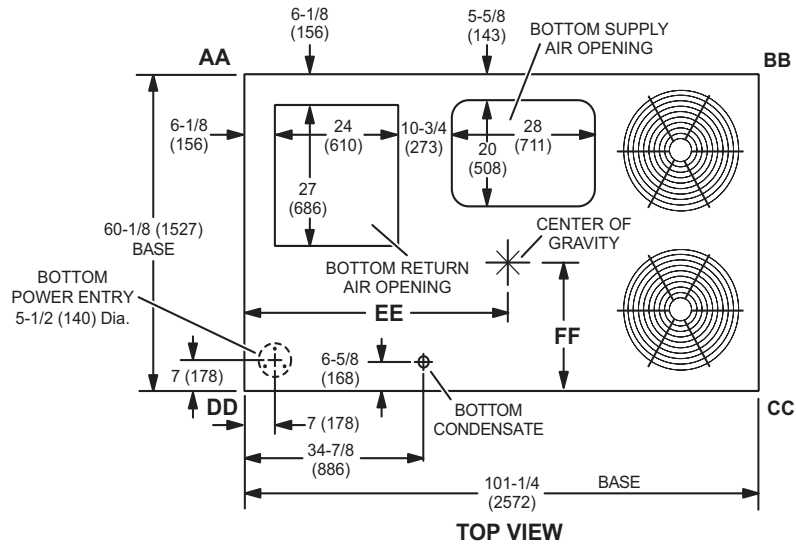

DIMENSIONS - UNIT - INCHES (MM) - 150 MODELS

Model No.	CORNER WEIGHTS																CENTER OF GRAVITY							
	AA				BB				CC				DD				EE				FF			
	Base		Max.		Base		Max.		Base		Max.		Base		Max.		Base		Max.		Base		Max.	
	lbs.	kg	lbs.	kg	lbs.	kg	lbs.	kg	lbs.	kg	lbs.	kg	lbs.	kg	lbs.	kg	in.	mm	in.	mm	in.	mm	in.	mm
150	348	158	398	180	303	137	337	153	321	146	353	160	377	171	426	193	46.5	1181	45.5	1156	24.5	622	25.5	648

Base Unit - The unit with NO OPTIONS.

Max. Unit - The unit with ALL OPTIONS Installed (Economizer, etc.).

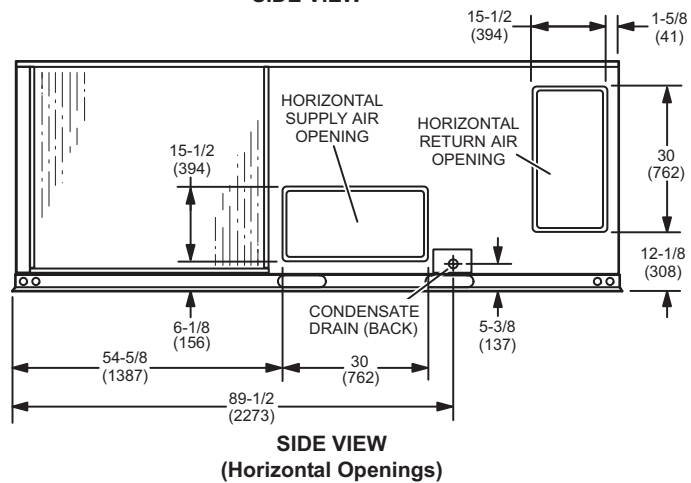
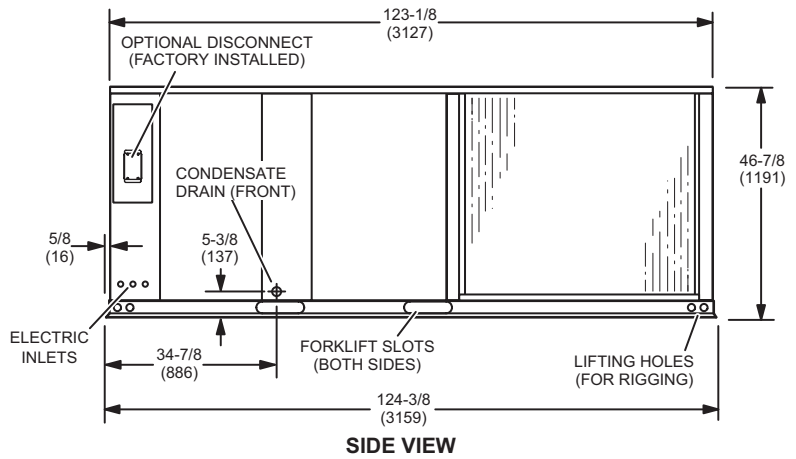
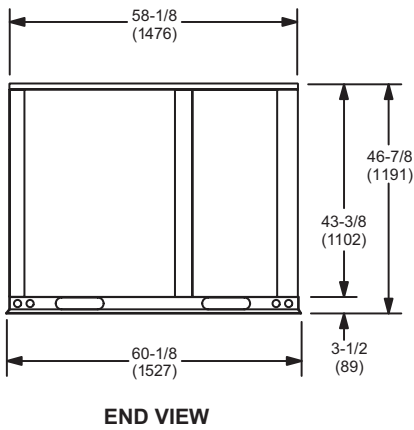
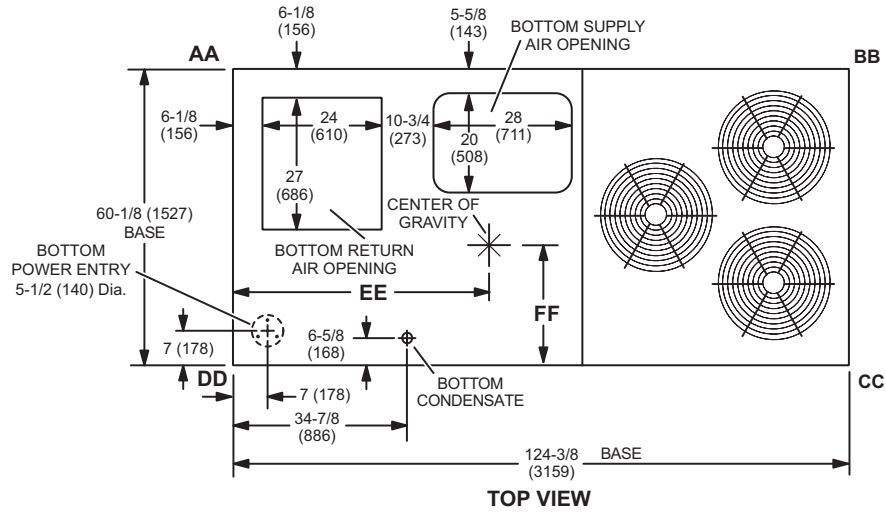

UNIT ON CURB LOCATION - KHA150

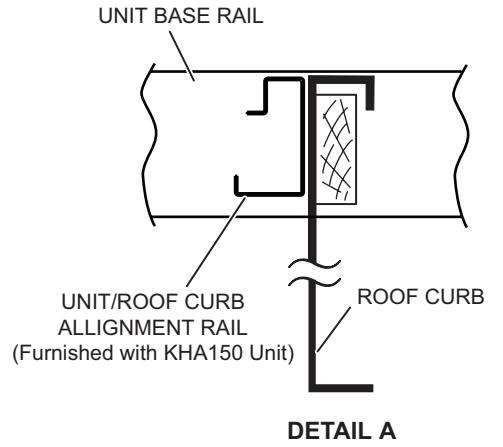
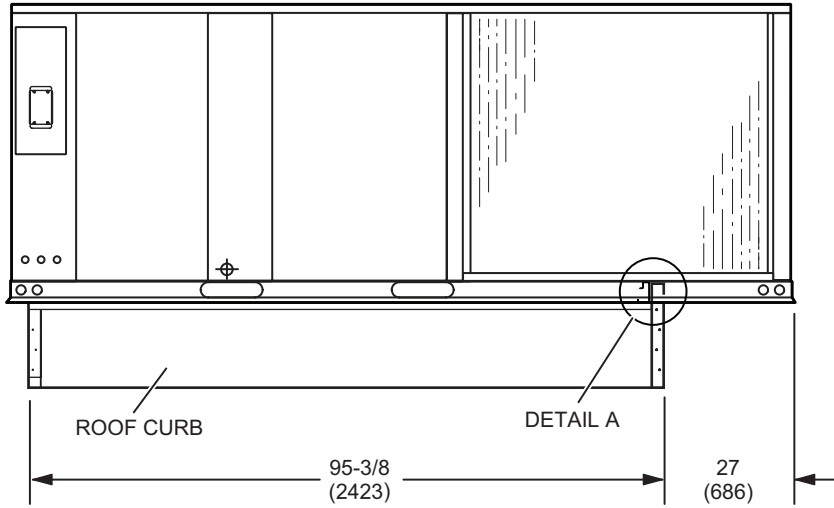

SIDE VIEW

OUTDOOR AIR HOOD DETAIL

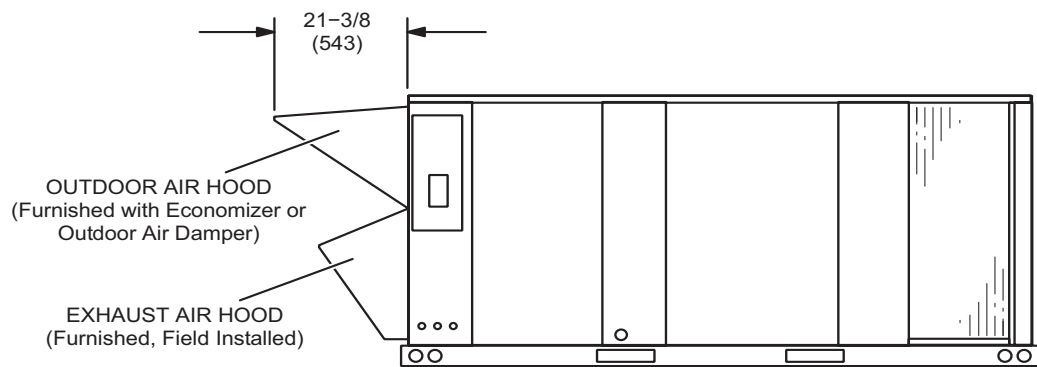

DIMENSIONS - ACCESSORIES - INCHES (MM)

HORIZONTAL ECONOMIZER APPLICATION

(With Furnished Barometric Relief Dampers and Optional Horizontal Discharge Kit - Required)

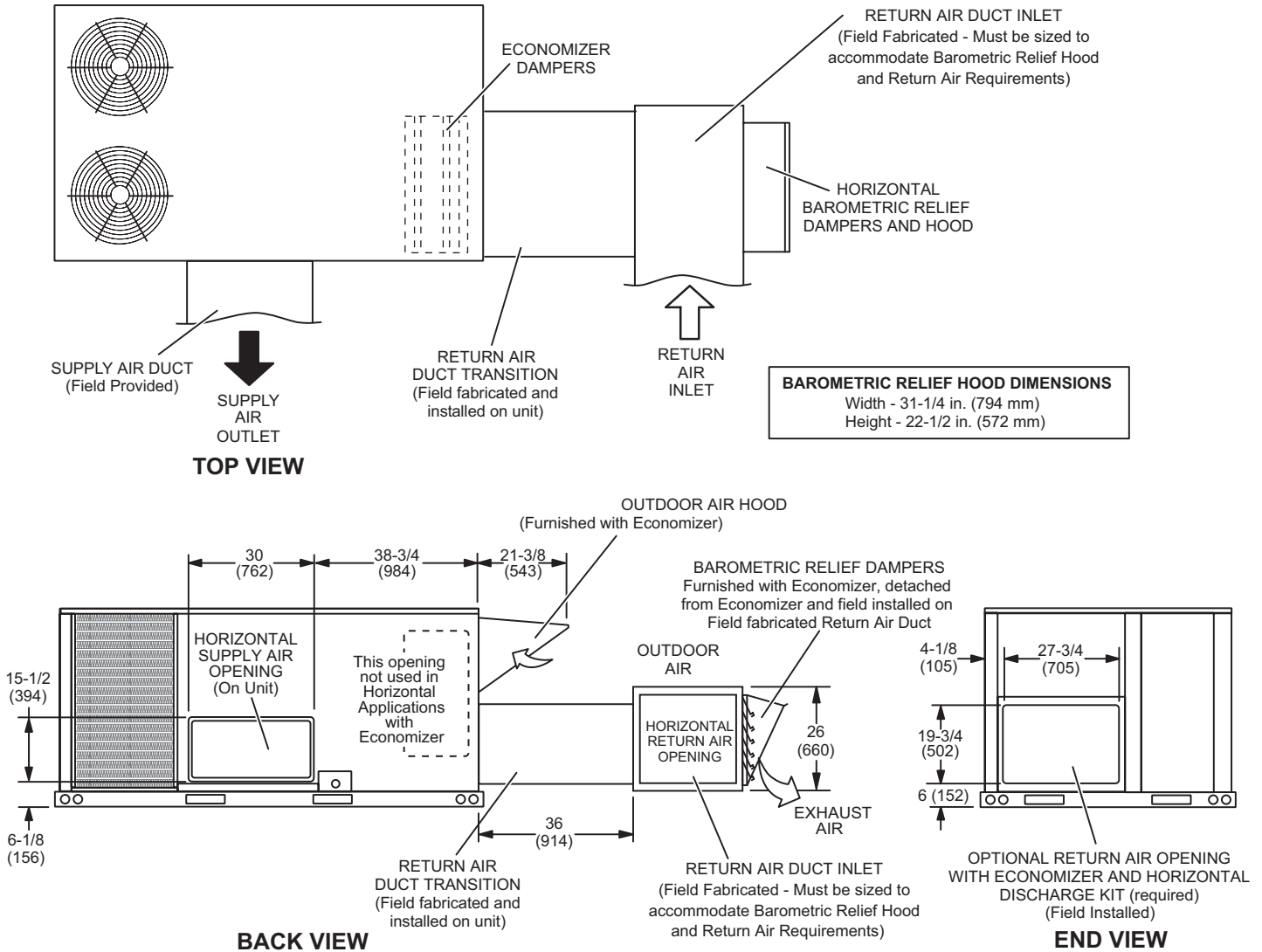

NOTE - Return Air Duct and Transition must be supported.

BAROMETRIC RELIEF DAMPERS (Furnished with Economizer)

(Field installed in horizontal return air duct adjacent to unit)

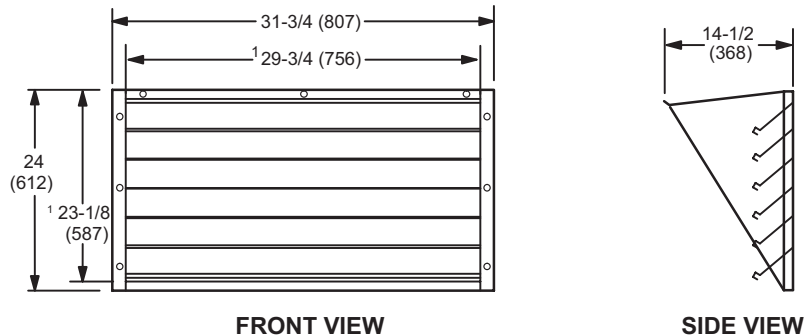

¹ NOTE - Opening size required in return air duct.

DIMENSIONS - ACCESSORIES - INCHES (MM)

HORIZONTAL ECONOMIZER APPLICATION

(with Optional Low Profile Horizontal Barometric Relief Dampers and Horizontal Discharge Kit - Required)

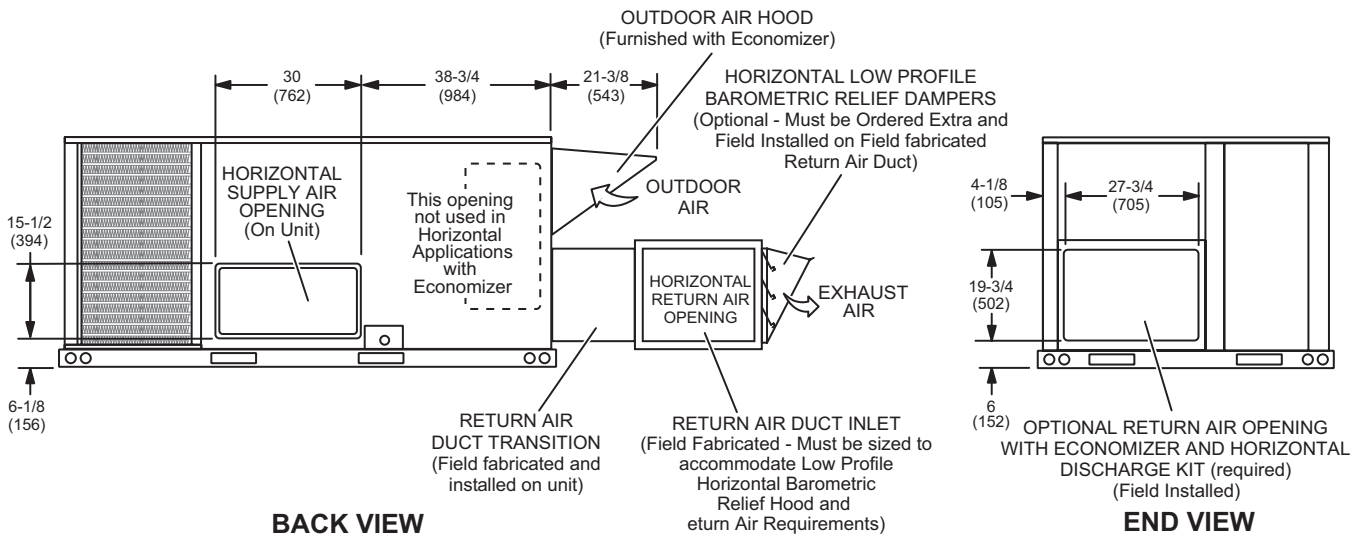
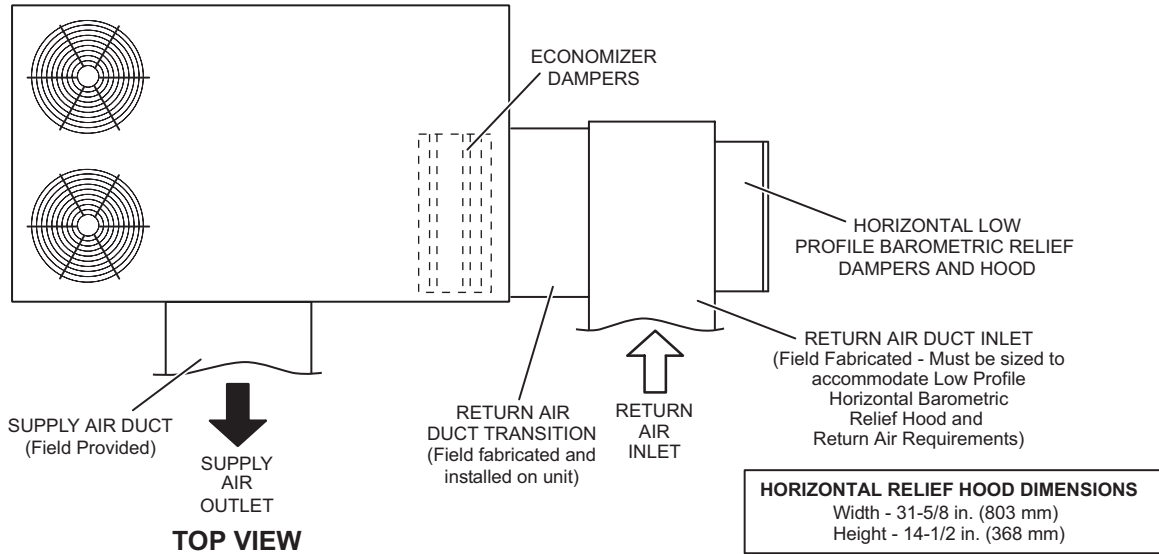

NOTE - Return Air Duct and Transition must be supported.

HORIZONTAL LOW PROFILE BAROMETRIC RELIEF DAMPERS
 (Field installed in horizontal return air duct adjacent to unit)

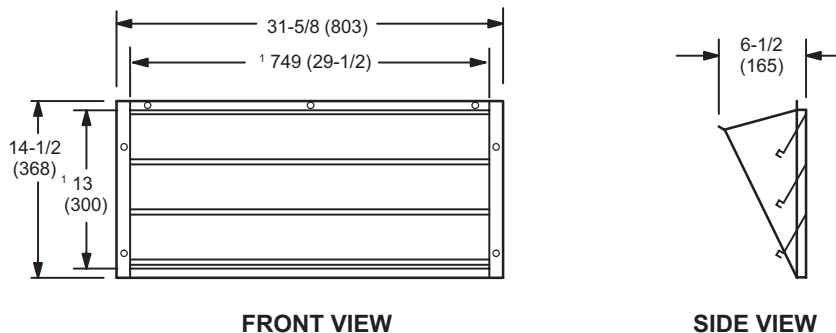

¹ NOTE - Opening size required in return air duct.

DIMENSIONS - ACCESSORIES - INCHES (MM)

HYBRID ROOF CURBS - DOUBLE DUCT OPENING

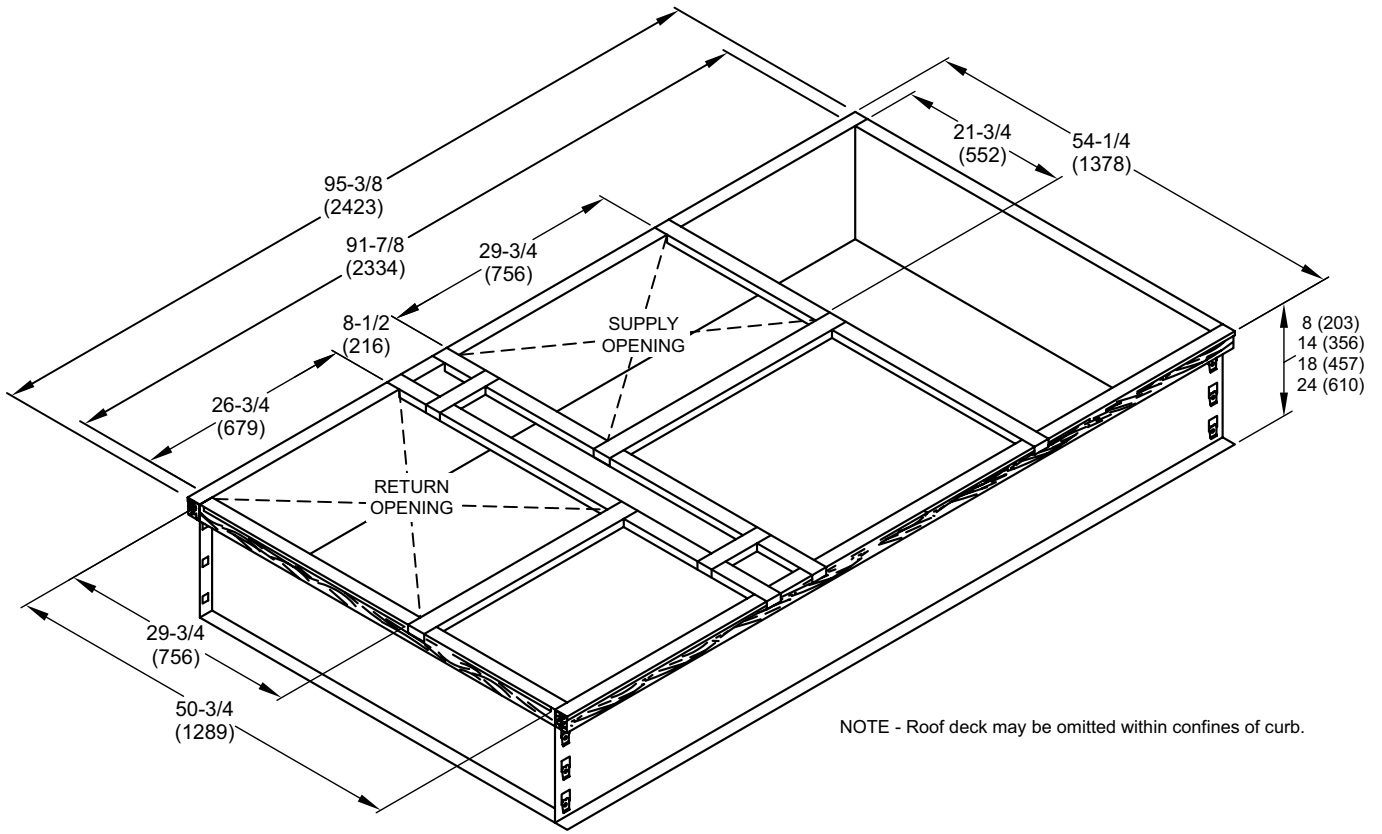

TYPICAL FLASHING DETAIL FOR ROOF CURB

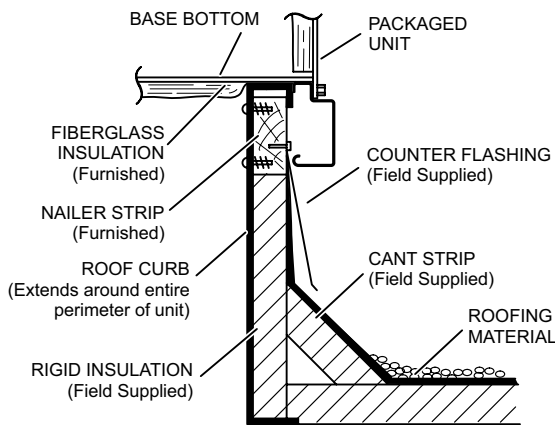

DETAIL ROOF CURB

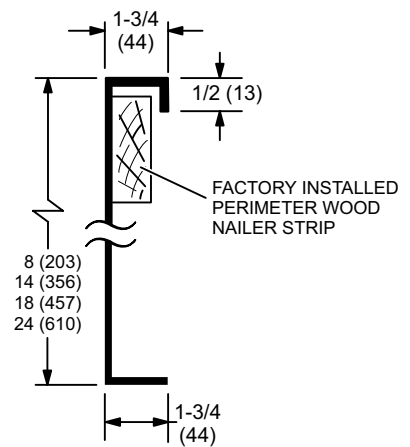

DIMENSIONS - ACCESSORIES - INCHES (MM)

ADJUSTABLE PITCH CURBS - DOUBLE DUCT OPENING

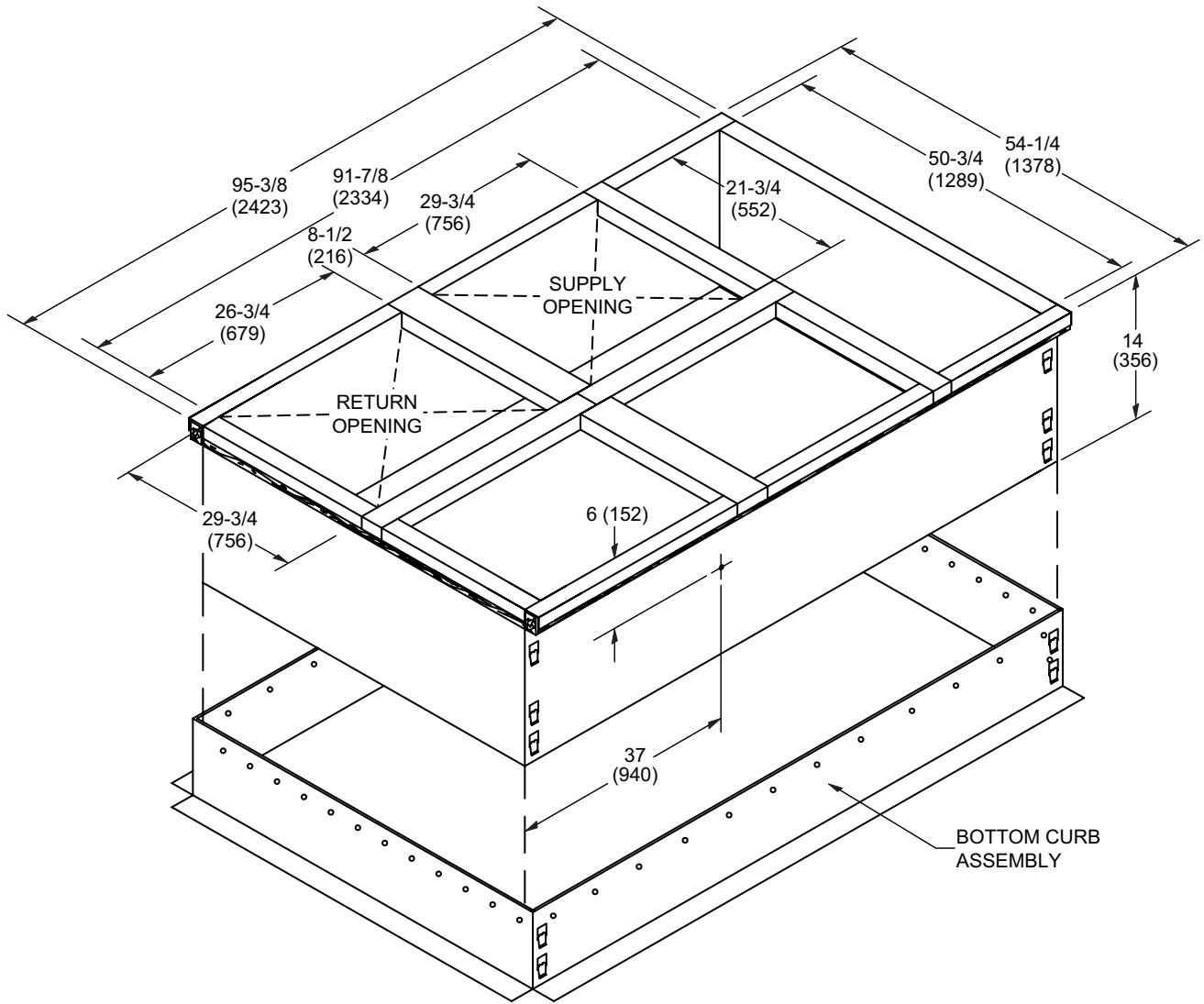

NOTE - Maximum slope pitch is 3/4 in. per 1 foot (19 mm per 305 mm) in any one direction.

TYPICAL FLASHING DETAIL FOR ROOF CURB

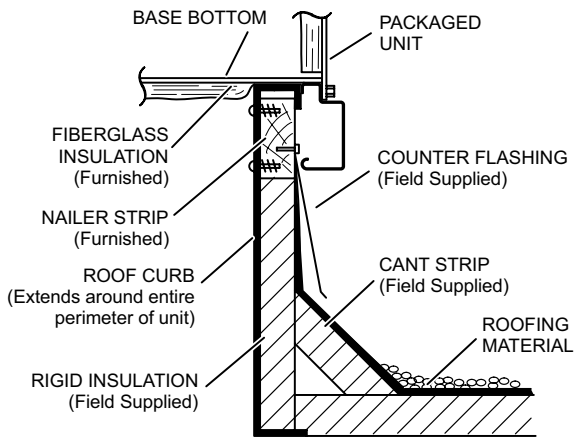

DETAIL ROOF CURB

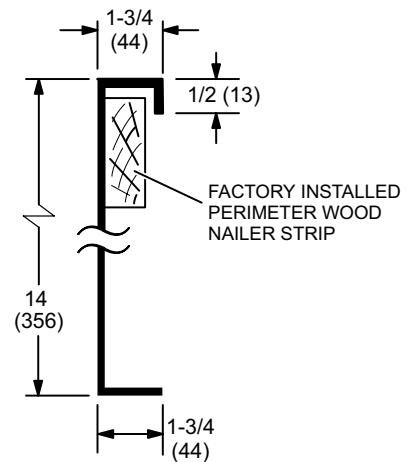

DIMENSIONS - ACCESSORIES - INCHES (MM)

ROOF CURBS WITH SUPPLY & RETURN AIR TRANSITIONS FOR CEILING DIFFUSERS

C1DIFF30B-1 ROUND TRANSITIONS
(for 092 models with FD11-95, RTD11-95 Diffusers)

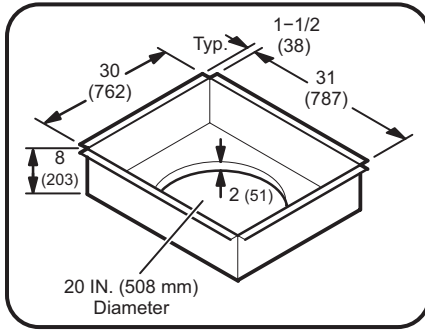

C1DIFF31B-1 & C1DIFF32B-1 RECTANGULAR TRANSITIONS
(for 102 thru 150 models with FD11-135-185, RTD11-135-185 Diffusers)

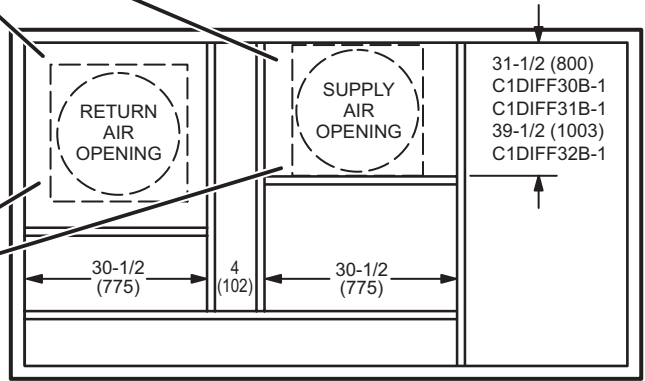
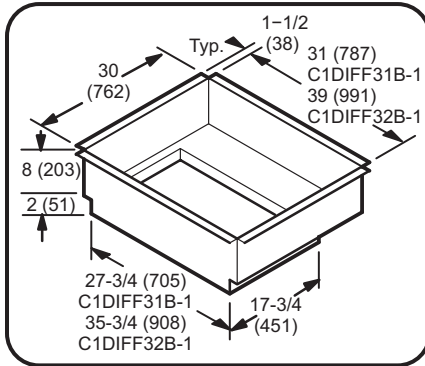

TOP VIEW

DIMENSIONS - ACCESSORIES - INCHES (MM)

COMBINATION CEILING SUPPLY AND RETURN DIFFUSERS

STEP-DOWN CEILING DIFFUSER

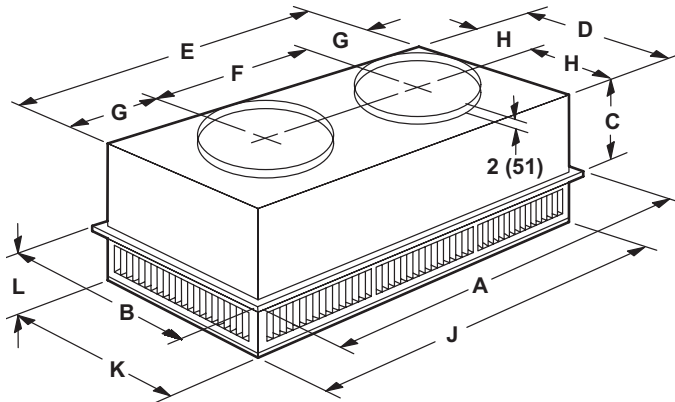

FLUSH CEILING DIFFUSER

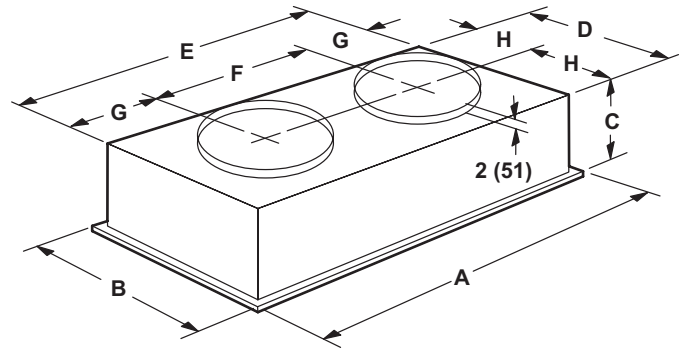

Model Number		RTD11-95
A	in.	47-5/8
	mm	1159
B	in.	29-5/8
	mm	752
C	in.	14-3/8
	mm	365
D	in.	27-1/2
	mm	699
E	in.	45-1/2
	mm	1158
F	in.	22-1/2
	mm	572
G	in.	11-1/2
	mm	292
H	in.	13-3/4
	mm	349
J	in.	45-1/2
	mm	1156
K	in.	27-1/2
	mm	699
L	in.	8-1/8
	mm	206
Duct Size	in.	20 round
	mm	508 round

Model Number		FD11-95
A	in.	47-5/8
	mm	1159
B	in.	29-5/8
	mm	752
C	in.	16-5/8
	mm	422
D	in.	27
	mm	686
E	in.	45
	mm	1143
F	in.	22-1/2
	mm	572
G	in.	11-1/4
	mm	286
H	in.	13-1/2
	mm	343
Duct Size	in.	20 round
	mm	508 round

DIMENSIONS - ACCESSORIES - INCHES (MM)

COMBINATION CEILING SUPPLY AND RETURN DIFFUSERS

STEP-DOWN CEILING DIFFUSER

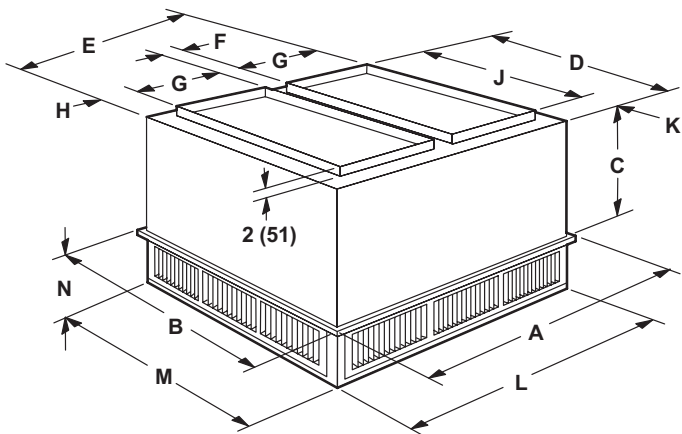

FLUSH CEILING DIFFUSER

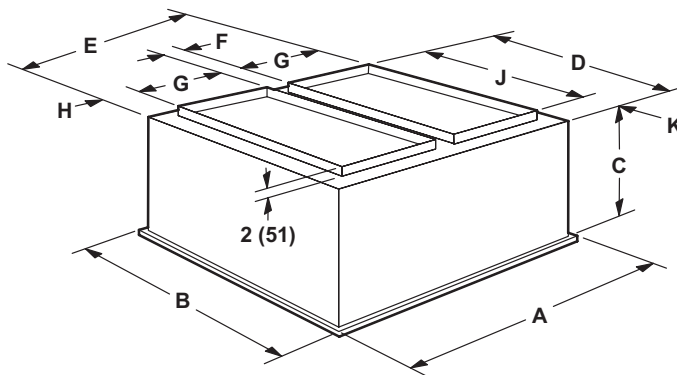

Model Number		RTD11-135	RTD11-185
A	in.	47-5/8	47-5/8
	mm	1210	1210
B	in.	35-5/8	47-5/8
	mm	905	1210
C	in.	20-5/8	24-5/8
	mm	524	625
D	in.	33-1/2	45-1/2
	mm	851	1156
E	in.	45-1/2	45-1/2
	mm	1156	1156
F	in.	4-1/2	4-1/2
	mm	114	114
G	in.	18	18
	mm	457	457
H	in.	2-1/2	2-1/2
	mm	64	64
J	in.	28	36
	mm	711	914
K	in.	2-3/4	4-3/4
	mm	70	121
L	in.	45-1/2	45-1/2
	mm	1156	1156
M	in.	33-1/2	45-1/2
	mm	851	1156
N	in.	9-1/8	10-1/8
	mm	232	257
Duct Size	in.	18 x 28	18 x 36
	mm	457 x 711	457 x 914

Model Number		FD11-135	FD11-185
A	in.	47-5/8	47-5/8
	mm	1210	1210
B	in.	35-5/8	47-5/8
	mm	905	1210
C	in.	23-1/4	29-1/4
	mm	591	743
D	in.	33	45
	mm	838	1143
E	in.	45	45
	mm	1143	1143
F	in.	4-1/2	4-1/2
	mm	114	114
G	in.	18	18
	mm	457	457
H	in.	2-1/4	2-1/4
	mm	57	57
J	in.	28	36
	mm	711	914
K	in.	2-1/2	4-1/2
	mm	64	114
Duct Size	in.	18 x 28	18 x 36
	mm	457 x 711	457 x 914

REVISIONS

Section	Description
Options/Accessories	Updated catalog number for Standard Efficiency Economizer.



Visit us at www.allied-commercial.com

For the latest technical information, visit us at www.allied-commercial.com

Contact us at 1-800-448-5872

NOTE - Due to Allied Commercial ongoing commitment to quality, Specifications, Ratings and Dimensions subject to change without notice and without incurring liability. Improper installation, adjustment, alteration, service or maintenance can cause property damage or personal injury. Installation and service must be performed by a qualified installer and servicing agency.