

PRPDF16

PRODUCT SPECIFICATIONS

SINGLE STAGE GAS VALVE
TWO STAGE COMPRESSOR
VARIABLE SPEED BLOWER

FORM NO. PRPDF16-100 (10/2018)



MODEL NUMBER

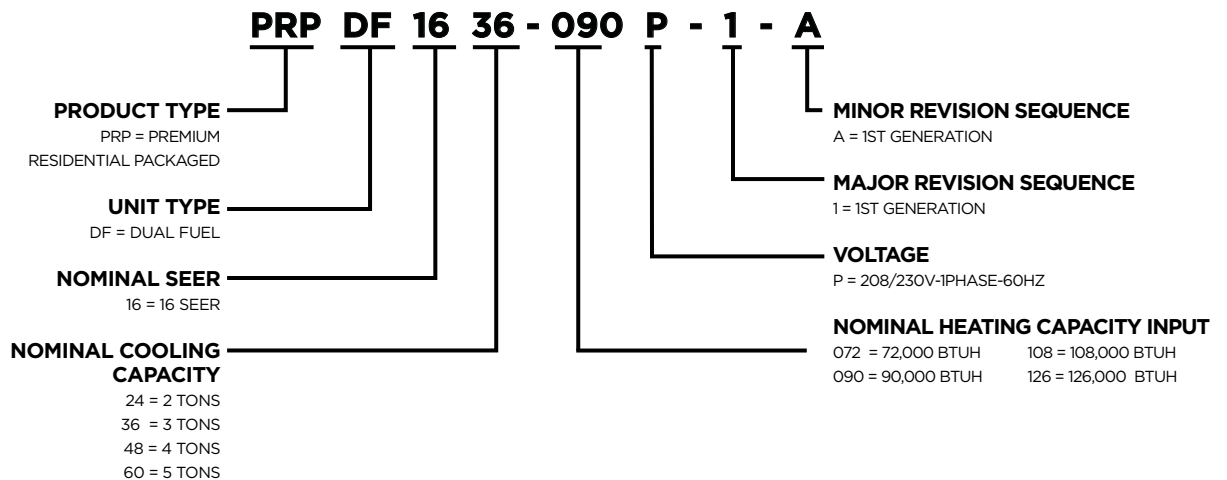

FEATURES AND BENEFITS

WARRANTY

10 year limited parts and compressor warranty available. See limited warranty document for details.

APPLICATIONS

Designed for outdoor installations at ground level or rooftop for residential and light commercial applications.

APPROVALS

AHRI Certified to AHRI Standard 210/240-2008.

Units are design certified by ETL Intertek.

Heating ratings are according to Department of Energy (DOE) test procedures and Federal Trade Commission (FTC) labeling regulations and are Certified by AHRI.

Cooling system rated according to DOE test procedures.

Units are ETL certified for the U.S. and Canada.

Packaged unit and components within bonded for grounding to meet safety standards required by UL.

Each unit test operated at the factory before shipment ensuring dependable operation at start-up.

HEATING SYSTEM

Heat Exchanger

Aluminized tubular steel for superior resistance to corrosion and oxidation.

Round surfaces create minimum air resistance and allow air to surround all surfaces for excellent heat transfer.

Heat exchanger has been laboratory life cycle tested.

Tri-Diamond Technology

This unique, advanced design allows more air to contact the tubular heat exchanger, providing greater heat transfer and efficiency.

Optimal heat exchange allows for a more compact and energy-efficient design.

The Tri-Diamond design eliminates issues caused by condensation developed during the cooling season leading to reliable startup every season.

Without a fresh air intake, Tri-Diamond also reduces oxide formation and corrosion caused by recirculation.

Inshot Burners

Aluminized steel inshot burners provide efficient trouble free operation.

Burner venturi mixes air and gas in correct proportion for proper combustion.

Burner assembly is removable from the unit as a single component for ease of service and each burner may be removed individually.

Single-Stage Gas Control Valve

24 volt redundant combination single -stage gas control valve combines manual shut off valve (On-Off), automatic electric valve and gas pressure regulation into a compact combination control.

Single-Stage Combustion Air Inducer

Heavy duty combustion air inducer prepurges heat exchanger and safely vents flue products.

Blower is controlled by the ignition control board.

Pressure switch proves blower operation before allowing gas valve to open.

Combustion air inducer operates during heating cycle.

Inducer also operates for the first 10 seconds of every cooling cycle to prevent insects from nesting in the flue outlet during cooling season.

Limit Controls

Automatic reset, primary limit is accurately located.

Primary limit factory installed on heating vestibule panel on all units.

Flame Rollout Switch

Manual reset switch is factory installed on burner box.

Switch provides protection from abnormal operating conditions.

Ignition Control Board

Ignition control board with LED diagnostics.

OPTIONAL ACCESSORIES

LPG/Propane Conversion Kit

Required for field changeover from natural gas to LPG/Propane.

REFRIGERATION SYSTEM

R-410A Refrigerant

Non-chlorine, ozone friendly, R-410A.

Unit pre-charged with refrigerant.

See Specification table.

Anti-Microbial Indoor Coil Drain Pan

Microban® Anti-Microbial additive resists growth of mold and mildew on drain pan which improves indoor air quality and reduces drain line blockage.

Includes drain pan overflow switch. Monitors condensate level in drain pan, shuts down unit if drain becomes clogged.

Outdoor Coil Fan

Weather protected heavy duty condenser fan motor with coated steel swept wing fan blades for long life.

Internally mounted.

Totally enclosed motor.

Fan guard constructed of corrosion-resistant coated steel.

Reversing Valve

4-way interchange reversing valve effects a rapid change in direction of refrigerant flow resulting in quick changeover from cooling to heating and vice versa.

High Pressure Switch

Shuts off unit if abnormal operating conditions cause the discharge pressure to rise above setting.

Loss of Charge Switch

Provides loss of charge protection by shutting off unit if liquid pressure falls below setting.

SCROLL COMPRESSOR

Two-Stage Compressor

Compressor features high efficiency with uniform suction flow, constant discharge flow, high volumetric efficiency and quiet operation.

Compressor consists of two involute spiral scrolls matched together to generate a series of crescent shaped gas pockets between them.

During compression, one scroll remains stationary while the other scroll orbits around it.

Gas is drawn into the outer pocket, the pocket is sealed as the scroll rotates.

As the spiral movement continues, gas pockets are pushed to the center of the scrolls. Volume between the pockets is simultaneously reduced.

When the pocket reaches the center, gas is now at high pressure and is forced out of a port located in the center of the fixed scrolls. During compression, several pockets are compressed simultaneously resulting in a smooth continuous compression cycle.

Continuous flank contact, maintained by centrifugal force, minimizes gas leakage and maximizes efficiency. Scroll compressor is tolerant to the effects of slugging and contaminants. If this occurs, scrolls separate, allowing liquid or contaminants to be worked toward the center and discharged.

During the compression process, there are several pockets in the scroll that are compressing gas. Modulation is achieved by venting a portion of the gas in the first suction pocket back to the low side of the compressor thereby reducing the effective displacement of the compressor.

A 24-volt DC solenoid valve inside the compressor controls

staging. When the 3-way solenoid is energized it moves the lift ring assembly to block the ports and the compressor operates at full-load or 100% capacity. When the solenoid is de-energized the lift ring assembly moves to unblock the compressor ports and the compressor operates at part-load or approximately 67% of its full-load capacity.

The “loading” and “unloading” of the two stage scroll is done “on the fly” without shutting off the single-speed compressor motor between stages.

Low gas pulses during compression reduces operational sound levels.

Compressor motor is internally protected from excessive current and temperature.

Compressor is installed in the unit on specially formulated, resilient rubber mounts for better sound dampening and vibration free operation.

Heavy Duty Compressor Blanket

Durable PVC outer cover with sound insulating inner polyester fiber.

SUPPLY AIR BLOWER

Direct Drive Blower

Each blower wheel statically and dynamically balanced.

Multi-speed operation is achieved by the use of an ECM (Electronically Commutated Motor) variable speed motor.

See Blower Performance tables.

Blower assembly easily removed for servicing.

ECM Variable Speed Blower Motor

Variable speed motor maintains specified air volume from 0 though 0.80 in. w.g. static range.

Motor is controlled by the blower control.

Change in blower speed is easily accomplished by simple jumper pin change on blower control.

Motor is resiliently mounted.

INDOOR AIR QUALITY

PCO Accessory.

PCO Accessory uses photocatalytic oxidation (PCO) technology to significantly reduce levels of airborne volatile organic compounds, cooking odors, common household odors, airborne dust particles, mold spores and pollen.

The PCO Accessory is mounted internally to the unit cabinet for superior indoor air quality.

Kit contains PCO cartridge, UVA lamp, UVA lampholder assembly, ballast box, wiring harness and all necessary hardware. Units are pre-wired with mounting brackets for kit.

Internal Filter Rack Kits

Available for 1 in. thick filters. Kit contains filter rails for mounting filters internal to unit. Filters are not furnished and must be field provided.

NOTE - The Internal Filter Rack Kit cannot be used with the PCO Accessory.

NOTE - Maximum acceptable filter efficiency is MERV 11.

CONTROLS

Electronic Blower Control

Two stages - HEAT and COOL (with four different air volume selections for each) are made by simple jumper pins.

ADJUST jumper pin allows approximately 10% higher, normal or 10% lower motor speed selection within (COOL) speeds selected for fine tuning air volume. See Blower Data tables.

NOTE - HEAT speeds are not affected by jumper change.

Cooling Airflow Ramp Up - At the beginning of a call for cooling, the blower will run at 82% of full airflow for 7.5 minutes. This improves the system’s moisture removal and saves blower power during cooling start.

Reduced Airflow Operation - For situations where humidity control is an issue, the variable speed motor can be connected to operate at

a 25% reduction in the normal airflow rate. The variable speed motor interface provides for connection of a thermostat with humidity control or a humidistat on the HUM terminal. When connected, the dehumidifier resistor on the interface must be cut. The control should be wired to open during high humidity, which will reduce blower airflow.

Defrost Control

Defrost control furnished as standard equipment.

Gives a defrost cycle for every 30, 60 or 90 minutes (adjustable) of compressor “on” time at outdoor coil temperatures below freezing.

Units are quiet-shift enabled. The compressor is de-energized entering and exiting the defrost cycle, reducing system sounds.

Sensor mounted on liquid line determines when defrost cycle is required and also when to terminate cycle.

Anti-short cycle, timed-off control incorporated into the board.

24 Volt Transformer

40VA transformer furnished and factory installed in control area.

Equipment Interface Module (EIM)

Allows the Comfort Sync® Thermostat to be used with residential packaged units.

Contains all necessary relays and controls to operate the system and communicate with the Comfort Sync® Thermostat.

Comfort Sync® Wi-Fi Thermostat

The Comfort Sync® Wi-Fi® Thermostat recognizes and connects conventional heating/cooling products to automatically configure and control the system (based on user-specified settings) for the highest level of comfort, performance and efficiency.

Wi-Fi remote temperature monitoring and adjustment through a home wireless network for desktop PCs, laptops and apps for smartphones or tablets. Also displays service alerts and reminders.

A simple easy-to-use touchscreen allows complete system configuration. Scheduled maintenance alerts, system warnings and troubleshooting are also displayed on thermostat screen.

One-Touch Away Mode - A quick and easy way to set the cooling and heating setpoints while away.

Weather-On-Demand - Live up-to-date weather data and five-day forecasts.

Easy to read 7-inch color screen (measured diagonally).

See the iComfort Wi-Fi® Thermostat Product Specifications bulletin in the Controls section for more information.

California Only

If installed in South Coast Air Quality Management District (SCAQMD) only: This furnace does not meet the SCAQMD Rule 1111 NOx emission limit (14 ng/J), and thus is subject to a mitigation fee of up to \$450. This furnace is not eligible for the Clean Air Furnace Rebate Program: www.CleanAirFurnaceRebate.com.

If installed in San Joaquin Valley Air Pollution Control District (SJVAPCD) only: This furnace does not meet the SJVAPCD Rule 4905 NOx emission limit (14 ng/J), and thus is subject to a mitigation fee of up to \$450.

CABINET

Conditioned areas insulated with foil faced insulation to minimize heat loss and reduce operating sound levels.

Pre-Painted galvanized steel for maximum durability.

Easy service access.

Steel louvered panels provides complete coil protection.

Airflow Choice

Units are shipped in horizontal configuration and can be field converted to downflow (vertical) airflow with optional Downflow Conversion Kit.

Electrical Inlets and Service Valves

Field wiring inlets are located in one central area of the cabinet. See dimension drawing.

Gauge ports located inside compressor service compartment of the cabinet.

OPTIONAL ACCESSORIES**Downflow Conversion Kit**

Required for field conversion to downflow (vertical) air. Kit consists of 2 duct covers to block off horizontal air openings on side of unit. Required for field conversion to downflow (vertical) air. Kit consists of 2 duct covers to block off horizontal air openings on side of unit.

Lifting Brackets

Available to facilitate rigging of the unit.

Clip Curb (Full Perimeter)

Mates to unit.

Roof curb can be assembled using interlocking tabs to fasten corners together. No tools required.

Available in 8 and 14 inch heights.

Shipped knocked down.

SPECIFICATIONS

GENERAL DATA	MODEL NO.		PRPDF1624	PRPDF1636	PRPDF1648	PRPDF1660
	NOMINAL TONNAGE		2	3	4	5
GAS HEAT AVAILABLE - SEE PAGE 7			- 72	- 90	- 108	- 126
COOLING / HEATING PERFORMANCE	Cooling	Total capacity - Btuh	23,000	35,000	47,000	57,000
		Total unit watts	1910	2910	3910	4950
		¹ SEER (Btuh/Watt)	16.00	16.00	16.00	15.50
		EER (Btuh/Watt)	12.0	12.0	12.0	11.5
	High Temp. Heat	Total capacity - Btuh	22,000	34,000	46,000	56,000
		Total unit watts	1791	2770	3740	4440
		COP	3.60	3.60	3.60	3.70
	HSPF Region IV		8.20	8.20	8.20	8.20
	Low Temp. Heat	Total capacity - Btuh	11,900	19,700	26,600	37,200
		Total unit watts	1480	2530	3500	4250
COP		2.36	2.28	2.23	2.57	
² Sound Rating Number (dB)		71	71	74	74	
REFRIGERANT	Type		R-410A	R-410A	R-410A	R-410A
	Charge		5 lbs. 5 oz.	8 lbs. 0 oz.	10 lbs. 8 oz.	10 lbs. 8 oz.
CONDENSATE DRAIN SIZE (FPT) - IN.			3/4	3/4	3/4	3/4
OUTDOOR COIL	Net Face Area - sq. ft.		16.3	15.5	18.6	18.6
	Tube diameter - in.		5/16	5/16	5/16	5/16
	Number of Rows		1	2	2	2
	Fins per in.		22	22	22	22
OUTDOOR COIL FAN	Motor horsepower		1/2	1/2	1/2	1/2
	Diameter - in.		22	22	24	24
	Number of blades		3	3	3	3
INDOOR COIL	Net Face Area - sq. ft.		4.4	4.4	6.8	6.8
	Tube Diameter - in.		5/16	3/8	3/8	3/8
	Number of Rows		3	3	3	3
	Fins per Inch		15	15	15	15
INDOOR BLOWER	Blower wheel size dia. x width - in.		10 x 6	10 x 8	10 x 10	12 x 9
	Motor horsepower		1/2	1/2	3/4	1
NET WEIGHT OF BASIC UNIT - LBS.			375	410	490	505
SHIPPING WEIGHT OF BASIC UNIT (1 PKG.) - LBS.			438	473	563	578
ELECTRICAL CHARACTERISTICS (60 HZ)			208/230V-1ph-60hz			
<p>¹ AHRI Certified to AHRI Standard 210/240: Cooling Ratings - 95°F outdoor air temperature and 80°F db/67°F wb entering indoor coil air. High Temperature Heating Ratings - 47°F db/43°F wb outdoor air temperature and 70°F entering indoor coil air. Low Temperature Heating Ratings - 17°F db/15°F wb outdoor air temperature and 70°F entering indoor coil air. ² Sound Rating Number rated in accordance with test conditions included in AHRI Standard 270.</p>						

OPTIONAL ACCESSORIES - ORDER SEPARATELY					
MODEL NO.		PRPHP1624	PRPHP1636	PRPHP1648	PRPHP1660
COMPRESSOR CRANKCASE HEATER	11X27	•	•	•	•
COMPRESSOR HARD START KIT	10J42	•	•		
	12J90			•	•
DOWNFLOW CONVERSION KIT	1.851401	•	•		
	1.851402			•	•
HORIZONTAL DISCHARGE RECT. TO 14" ROUNDS DUCT ADAPTER (QTY 25 SETS)	R104617-01	•	•		
	R104618-01			•	•
1" INTERNAL FILTER RACK KIT (FILTERS NOT FURNISHED)	(1) 20 x 20 + (1) 14 X 20	11U73	•	•	
	(2) 20 x 20	11U74			•
LIFTING BRACKETS		11U76	•	•	•
CLIP CURBS	8 in. Height	14W71	•	•	
		14W72			•
	14 in. Height	14V68	•	•	
		14V69			•
ADJUSTABLE PITCH ROOF CURB AVAILABLE 3RD PARTY ONLY	N/A	•	•		
	N/A			•	•
PCO ACCESSORY		Y8717	•	•	•
MAINTENANCE SUPPLIES - ORDER SEPARATELY					
PCO ACCESSORY MAINTENANCE KIT (INCLUDES MEDIA CARTRIDGE AND UVA LAMP)		Y8718	•	•	•
CONTROLS - ORDER SEPARATELY					
COMFORT SYNC® THERMOSTAT		1.841197	•	•	•
EQUIPMENT INTERFACE MODULE (EIM) - REQUIRED WITH COMFORT SYNC® THERMOSTAT		R104785-01	•	•	•
³ OUTDOOR AIR TEMPERATURE SENSOR		X2658	•	•	•
⁴ DISCHARGE AIR TEMPERATURE SENSOR		88K38	•	•	•
<p><small>1 Filters are not furnished and must be field provided. Maximum acceptable filter efficiency is MERV 11. 1" Thick.</small></p> <p><small>2 Filter Rack Kit cannot be used with the Healthy Climate® PCO Accessory.</small></p> <p><small>3 Remote Outdoor Temperature Sensor is recommended for heat pump balance point control and to lock out some of the the electric heating elements where two-stage control is applicable. Also allows the thermostat to display outdoor temperature.</small></p> <p><small>4 Used with the iComfort® S30 and iComfort Wi-Fi® Thermostats for optional service diagnostics.</small></p>					

SPECIFICATIONS - GAS HEAT

GENERAL DATA	MODEL NO.	PRPDF1624	PRPDF1636	PRPDF1648	PRPDF1660
HEATING INPUT		-072	-090	-108	-126
HEATING CAPACITY BTUH	Input	72,000	90,000	108,000	126,000
	Output	58,000	73,000	88,000	102,000
AFUE		81%	81%	81%	81%
TEMPERATURE RISE - °F	Second Stage	40-70	40-70	40-70	45-75
GAS SUPPLY CONNECTION (FPT) - IN.		1/2	1/2	1/2	1/2
MIN. RECOMMENDED GAS SUPPLY PRESSURE		5 in. w.g. Natural Gas, 11 in. w.g. LPG/Propane			
OPTIONAL ACCESSORIES - ORDER SEPARATELY					
LPG/PROPANE CONVERSION KIT		11U77	11U77	11U77	11U77
<i>1 Annual Fuel Utilization Efficiency based on U.S. DOE test procedures and FTC labeling regulations.</i>					

HIGH ALTITUDE DERATE

Units may be installed at altitudes up to 4500 feet above sea level without any modification. At altitudes above 4500 feet, units must be derated 4% for every 1000 feet above sea level. Example - At an altitude of 6000 feet the unit would require a derate of 24%.

NOTE - This is the only permissible derate for these units.

FIELD WIRING

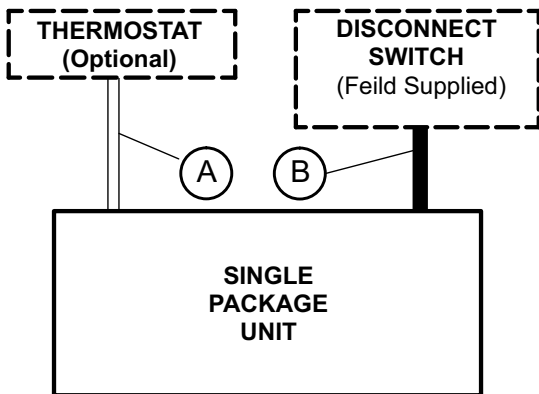

A – Seven Wire Low Voltage (Electronic)

B – Two Wire Power (See Electrical Data Table)

– Field Wiring Not Furnished –

INSTALLATION CLEARANCES		
	IN.	MM
Front (heat exchanger access)	24	610
Right Side (blower access)	24	610
Left Side (evaporator coil access)	24	610
Back	0	0
Top	48	1219

MINIMUM CLEARANCE TO COMBUSTIBLE MATERIAL		
	IN.	MM
Front	0	0
Back	0	0
Right Side (vent cover)	12	305
Left Side	0	0
Top	0	0
Below Unit	0	0

BLOWER DATA

PRPDF1624 BLOWER PERFORMANCE 0 THROUGH 0.80 IN. W.G. EXTERNAL STATIC PRESSURE RANGE												
"ADJUST" JUMPER SETTING	BLOWER CONTROL JUMPER SPEED POSITIONS											
	"COOL / HEAT PUMP" SPEED - CFM				"GAS HEAT" SPEED - CFM				"CONTINUOUS FAN" SPEED - CFM			
	A	'B	C	D	A	'B	C	D	A	B	C	D
+	1100	880	660	440	---	---	---	---	550	440	330	220
NORM	1000	800	600	400	1220	1100	1000	900	500	400	300	200
-	900	720	540	360	---	---	---	---	450	360	270	180

¹ Factory Settings.
NOTE - All air data is measured external to unit without air filters.
NOTE - 1st Stage airflow is 70% of 2nd Stage airflow (full capacity) in cooling mode.

PRPDF1636 BLOWER PERFORMANCE 0 THROUGH 0.80 IN. W.G. EXTERNAL STATIC PRESSURE RANGE												
"ADJUST" JUMPER SETTING	BLOWER CONTROL JUMPER SPEED POSITIONS											
	"COOL / HEAT PUMP" SPEED - CFM				"GAS HEAT" SPEED - CFM				"CONTINUOUS FAN" SPEED - CFM			
	A	'B	C	D	A	'B	C	D	A	B	C	D
+	1430	1320	1100	880	---	---	---	---	715	660	550	440
NORM	1300	1200	1000	800	1400	1330	1220	1080	650	600	500	400
-	1170	1080	900	720	---	---	---	---	585	540	450	360

¹ Factory Settings.
NOTE - All air data is measured external to unit without air filters.
NOTE - 1st Stage airflow is 70% of 2nd Stage airflow (full capacity) in cooling mode.

PRPDF1648 BLOWER PERFORMANCE 0 THROUGH 0.80 IN. W.G. EXTERNAL STATIC PRESSURE RANGE												
"ADJUST" JUMPER SETTING	BLOWER CONTROL JUMPER SPEED POSITIONS											
	"COOL / HEAT PUMP" SPEED - CFM				"GAS HEAT" SPEED - CFM				"CONTINUOUS FAN" SPEED - CFM			
	A	'B	C	D	A	'B	C	D	A	B	C	D
+	1980	1760	1540	1320	---	---	---	---	990	880	770	660
NORM	1800	1600	1400	1200	1640	1460	1380	1220	900	800	700	600
-	1620	1440	1260	1080	---	---	---	---	810	720	630	540

¹ Factory Settings.
NOTE - All air data is measured external to unit without air filters.
NOTE - 1st Stage airflow is 70% of 2nd Stage airflow (full capacity) in cooling mode.

PRPDF1660 BLOWER PERFORMANCE 0 THROUGH 0.80 IN. W.G. EXTERNAL STATIC PRESSURE RANGE												
"ADJUST" JUMPER SETTING	BLOWER CONTROL JUMPER SPEED POSITIONS											
	"COOL / HEAT PUMP" SPEED - CFM				"GAS HEAT" SPEED - CFM				"CONTINUOUS FAN" SPEED - CFM			
	A	'B	C	D	A	'B	C	D	A	B	C	D
+	2200	1980	1760	1540	---	---	---	---	1100	990	880	770
NORM	2000	1800	1600	1400	1800	1680	1550	1440	1000	900	800	700
-	1800	1620	1440	1260	---	---	---	---	900	810	720	630

¹ Factory Settings.
NOTE - All air data is measured external to unit without air filters.
NOTE - 1st Stage airflow is 70% of 2nd Stage airflow (full capacity) in cooling mode.

HEATING RATINGS

MODEL	OUTDOOR TEMP - DB/WB °F									
	0/0		17/15		35/33		47/43		62/56	
	BTUH	KW	BTUH	KW	BTUH	KW	BTUH	KW	BTUH	KW
PRPDF1624	6100	1.30	11,900	1.48	18,100	1.67	22,100	1.80	27,200	1.95
PRPDF1636	11,100	2.36	19,700	2.53	28,700	2.71	34,700	2.83	42,200	2.98
PRPDF1648	14,900	3.33	26,600	3.50	39,100	3.68	47,400	3.81	57,800	3.96
PRPDF1660	24,800	4.06	37,200	4.25	50,300	4.45	59,000	4.59	69,900	4.75

INSTALLATION CLEARANCES		
	IN.	MM
Front	24	610
Right Side (blower access)	24	610
Left Side (evaporator coil access)	24	610
Back	0	0
Top	48	1219

DIMENSIONS - UNIT - INCHES (MM)

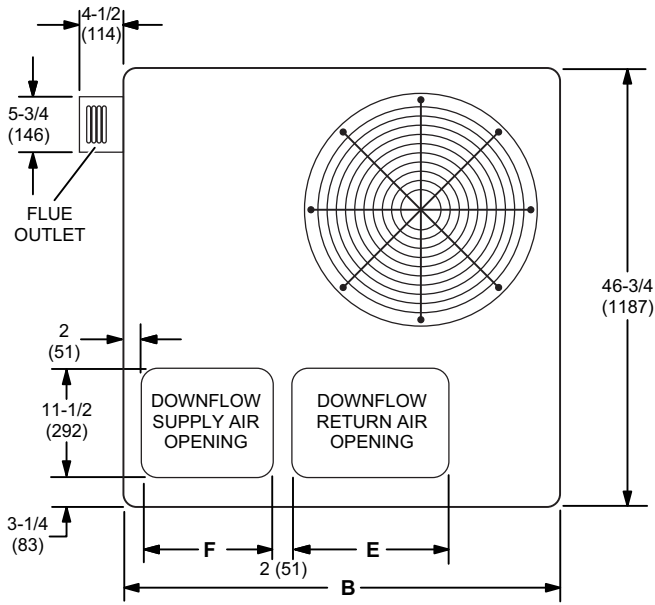

TOP VIEW

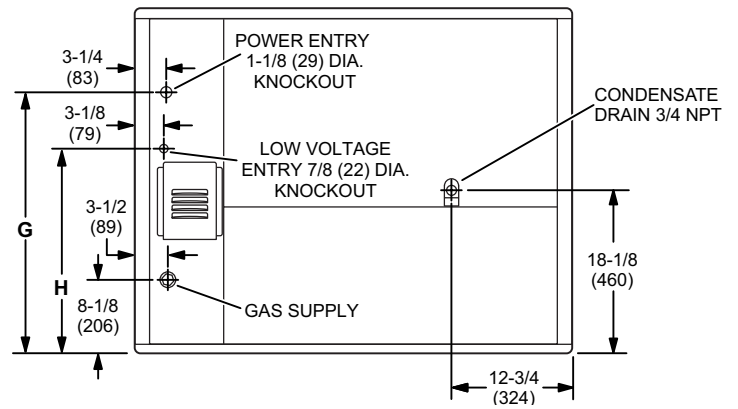
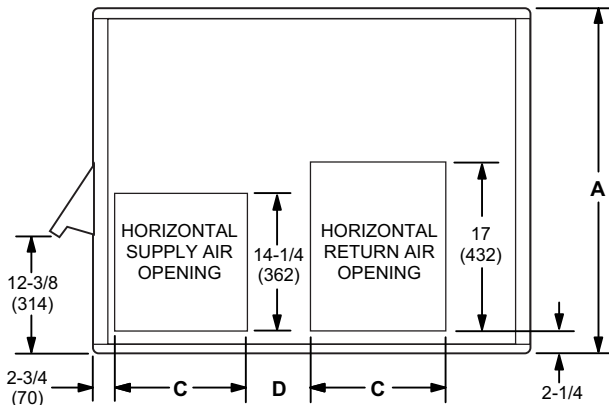

MODEL NO.	A		B		C		D		E	
	IN.	MM	IN.	MM	IN.	MM	IN.	MM	IN.	MM
PRP16DF24, 36	36-7/8	937	46-3/4	1187	13-3/8	340	5-7/8	149	16-3/4	425
PRP16DF48, 60	40-7/8	1038	55-1/4	1403	18-1/8	467	4-5/8	117	19-3/4	502
MODEL NO.	F		G		H					
	IN.	MM	IN.	MM	IN.	MM				
PRP16DF24, 36	14	356	28-1/8	714	22-1/8	562				
PRP16DF48, 60	19-1/2	495	32-1/8	816	26-1/8	664				

CLIP CURB

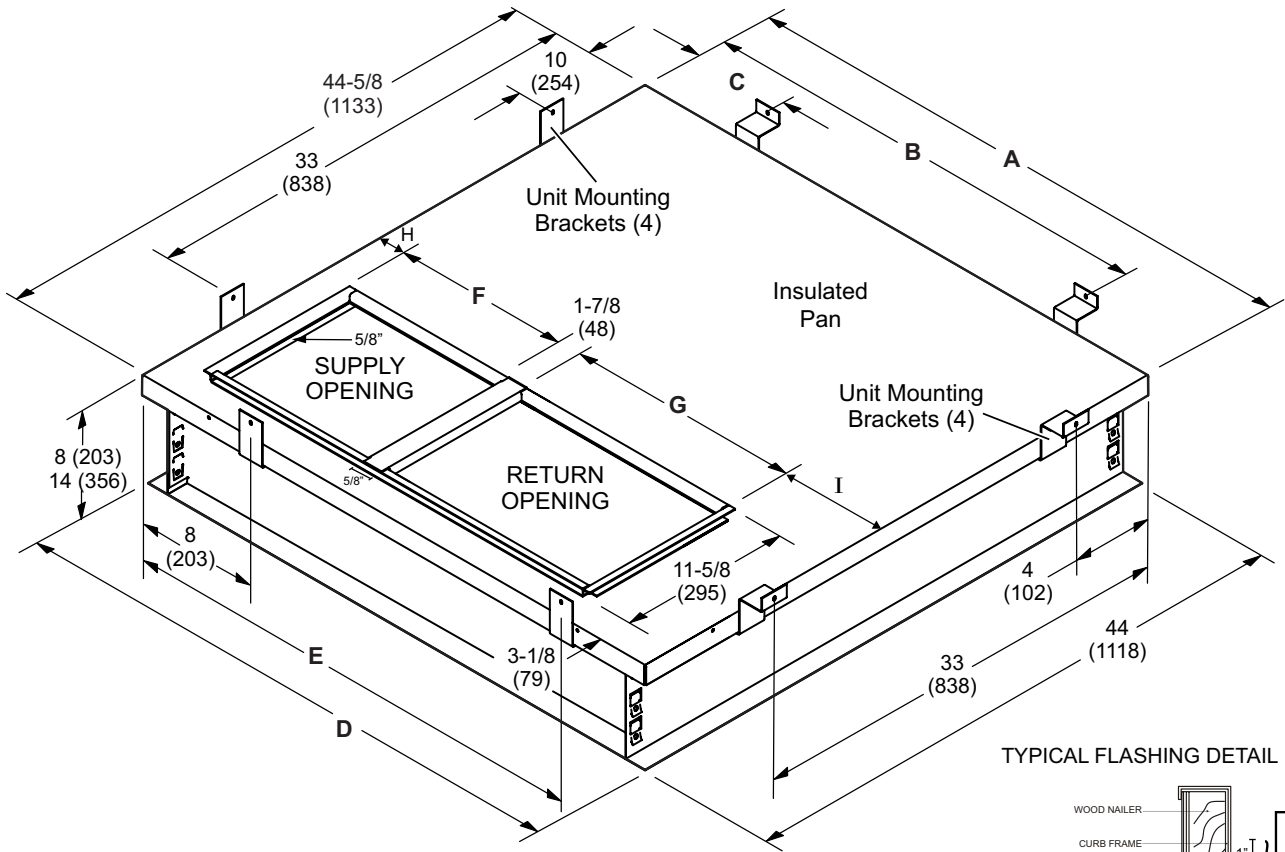

NOTE - Roof deck may be omitted within confines of curb.

TYPICAL FLASHING DETAIL

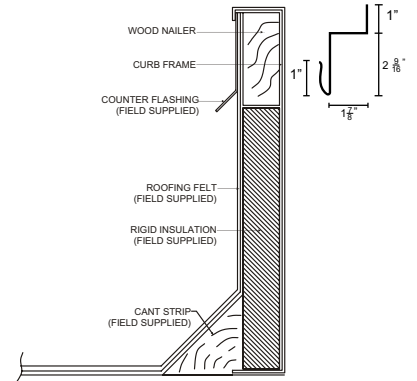

USAGE	A		B		C		D		E	
	IN.	MM	IN.	MM	IN.	MM	IN.	MM	IN.	MM
24, 36	44-5/8	1133	43	1092	18	457	44	1118	37	940
48, 60	53-1/8	1349	51	1295	24	610	52-1/2	1334	41	1041
USAGE	F		G		H		I			
	IN.	MM	IN.	MM	IN.	MM	IN.	MM		
24, 36	16.75	356	14.00	425	2	51	9-3/4	248		
48, 60	19.75	495	19.50	502	2	51	10	254		

ADJUSTABLE PITCH ROOF CURB

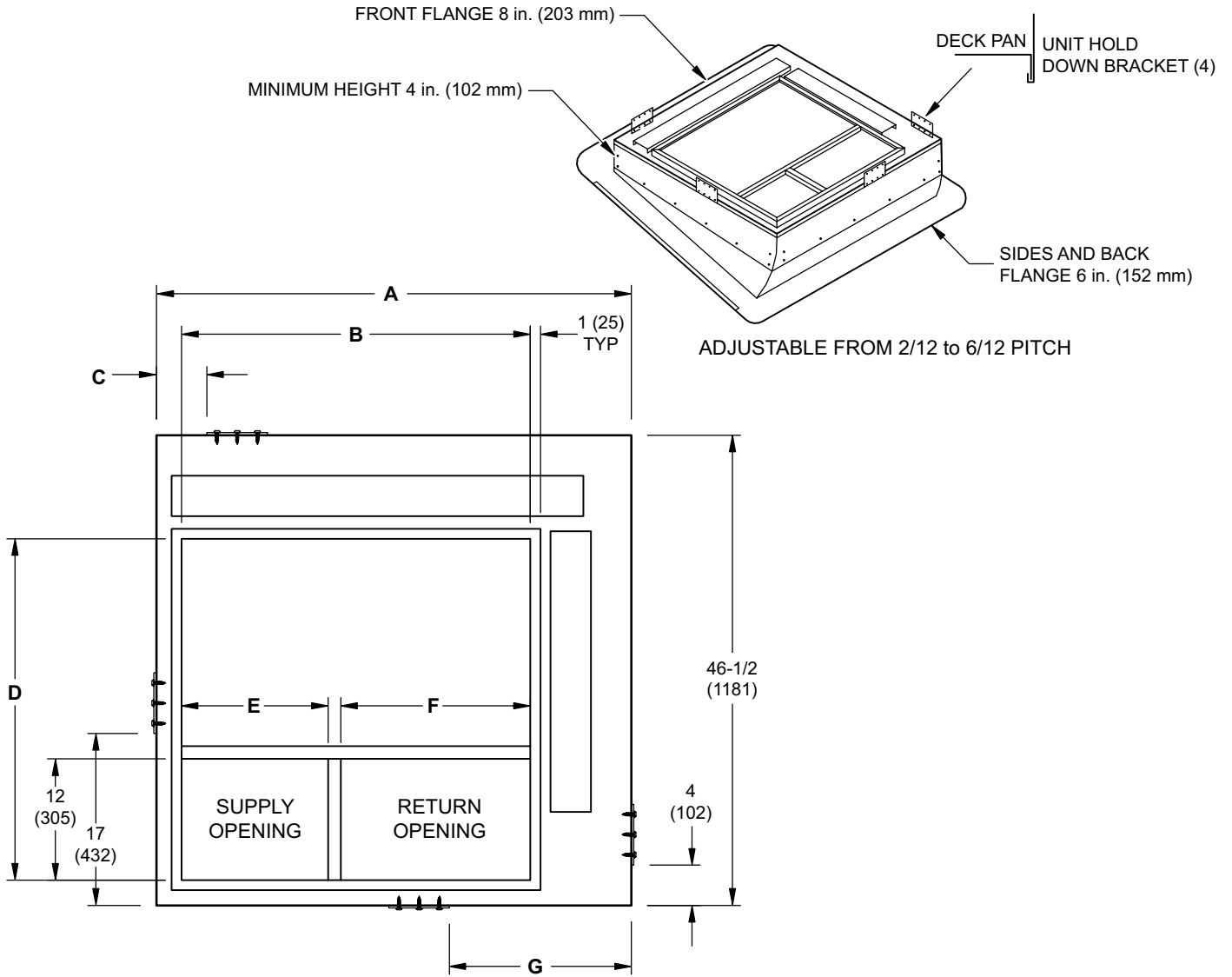

USAGE	A		B		C		D	
	IN.	MM	IN.	MM	IN.	MM	IN.	MM
24, 36	47	1194	34-1/2	876	5	127	33-3/4	857
48, 60	55-1/4	1403	42-3/8	1076	10	254	33	838
MODEL NO.	E		F		G			
	IN.	MM	IN.	MM	IN.	MM		
24, 36	14-1/2	368	18-3/4	476	18	457		
48, 60	20	508	21-1/8	537	18-1/4	464		

MUST SOURCE LOCALLY



1-800-448-5872

All specifications and illustrations subject to change without notice and without incurring obligations.