

4AC16

PRODUCT SPECIFICATIONS

16 SEER SPLIT SYSTEM AIR CONDITIONER

FORM NO. 4AC14-100 (12/2017)



- R410A Refrigerant
- High-quality condenser coil with copper tubing and enhanced lanced fin for maximum heat transfer capacity
- Top discharge directs hot air and sound away from living area and shrubbery
- All units factory run tested
- Easy access to electrical panels, pre-wired for easy hook-up
- Liquid line drier shipped loose
- All units ETL and ETL approved and AHRI Certified
- Charged for 15 feet of interconnecting tubing
- High pressure switch factory installed

WARRANTY

10 year limited warranty on compressor, 10 year limited warranty on all parts, extended warranty available*

**Warranty provides for a total of 10 years of limited warranty coverage (Standard 5-year limited parts warranty plus an additional 5-year limited extended parts warranty). Warranty must be registered online within 60 days of installation to qualify for 10-year coverage. Unregistered equipment defaults to 5-year coverage. Lifetime limited heat exchanger warranty applies to registered equipment only (Standard 20 years with no online registration). See full warranty at www.alliedair.com for terms, conditions and exclusions.*



MODEL NUMBER GUIDE

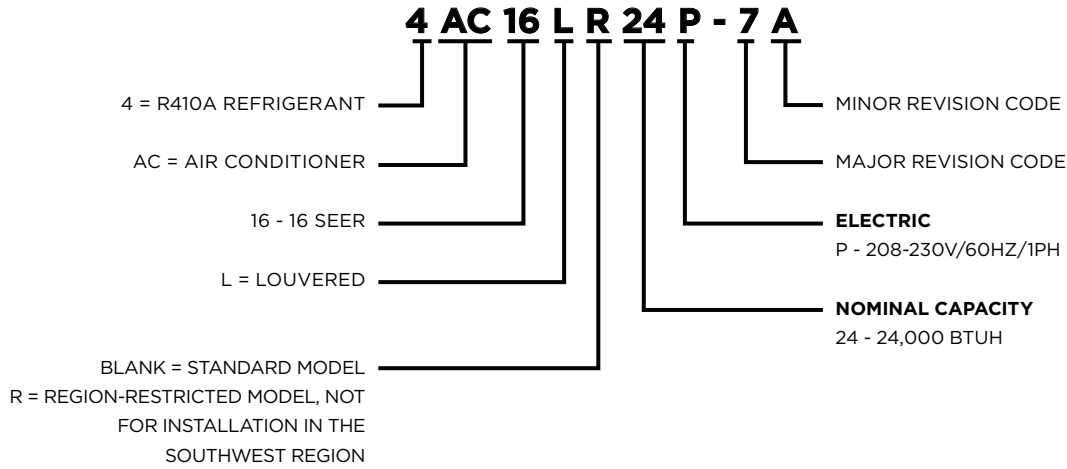

PHYSICAL AND ELECTRICAL DATA

Model	Volts/Hz/Phase	Voltage Range	Min. Circuit Amp.	Max. Over-current Device (amps)	Compressor		Outdoor Fan Motor			Refrig. Charge (oz.)	Shipping Weight (lbs.)
					Rated Load (amps)	Locked Rotor (amps)	Rated Load (amps)	Rated HP	Nom. RPM		
4AC16L8P	208-230/60/1	197-253	12.4	20	9.4	56.6	0.7	1/10	1075	77	150
4AC16LR18P											
4AC16L24P	208-230/60/1	197-253	15.0	25	11.2	60.8	1.0	1/6	825	86	160
4AC16LR24P											
4AC16L30P	208-230/60/1	197-253	17.0	25	12.8	67.8	1.0	1/6	825	100	180
4AC16LR30P											
4AC16L36P	208-230/60/1	197-253	18.6	30	14.1	83	1.0	1/6	825	102	185
4AC16LR36P											
4AC16L41P	208-230/60/1	197-253	22.6	35	16.7	79	1.7	1/4	825	161	210
4AC16L42P	208-230/60/1	197-253	24.1	40	17.9	113	1.7	1/4	825	160	208
4AC16LR42P											
4AC16L47P	208-230/60/1	197-253	26.7	45	19.9	109	1.8	1/3	825	179	251
4AC16L48P	208-230/60/1	197-253	26.6	45	19.8	109	1.7	1/4	825	174	220
4AC16L59P	208-230/60/1	197-253	34.1	50	25.0	134	2.8	1/3	825	178	235
4AC16L60P	208-230/60/1	197-253	34.8	60	26.4	134	1.8	1/3	825	192	253

Note:
Weights listed are unit weights with packaging
+ Factory charged for 15 feet of line set. Adjust per installation instructions.

UNIT DIMENSIONS & SOUND RATINGS

Model	Dimensions (inch)			Sound Rating (dBA)
	A - Width	B - Depth	C - Height	
4AC16L18P	24.25	24.25	29	71
4AC16LR18P				
4AC16L24P	28.25	28.25	29	76
4AC16LR24P				
4AC16L30P	28.25	28.25	37	74
4AC16LR30P				
4AC16L36P	28.25	28.25	37	74
4AC16LR36P				
4AC16L41P	28.25	28.25	37	76
4AC16L42P	28.25	28.25	33	76
4AC16LR42P				
4AC16L47P	28.25	28.25	37	80
4AC16L48P	28.25	28.25	33	80
4AC16L59P	32.25	32.25	37	78
4AC16L60P	32.25	32.25	37	80

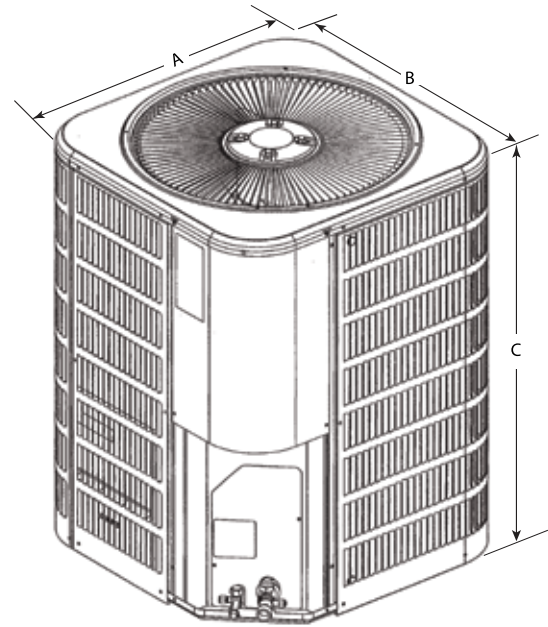

Note:
 Dimensions listed are unit sizes w/o packaging
 * Denotes: "L", "B"

COOLING PERFORMANCE WITH EVAPORATOR COILS AC'S

Outdoor Model	Indoor Model	SEER	EER	AHRI Rated Capacity(1) BTUH	Rated Sensible BTUH	CFM	Refrigerant Connection				Refrigerant Line Set		Indoor Expansion Device	
							Outdoor		Indoor		Suction	Liquid	Piston(2)	TXV
	Suction						Liquid	Suction	Liquid					
4AC16L18P-1	EC4X29(A,B)+45 SEC BLOWER DELAY	14.5	12.2	18000	13000	650	3/4	3/8	3/4	3/8	3/4	3/8	0.053	A4TXV01
	E*1P23(A,B)+TDR	14.25	12.2	18000	13000	650	3/4	3/8	3/4	3/8	3/4	3/8	0.053	
	E*1P29(A,B)+TDR	14.25	12.2	18000	13000	650	3/4	3/8	3/4	3/8	3/4	3/8	0.053	
	E*1P36(A,B,C)+TDR	14.25	12.2	18000	13000	650	3/4	3/8	3/4	3/8	3/4	3/8	0.053	
	EC4X23(A,B)+45 SEC BLOWER DELAY	14.25	12.2	18000	13000	650	3/4	3/8	3/4	3/8	3/4	3/8	0.053	
	EC4X36(A,B,C)+45 SEC BLOWER DELAY	14.25	12.2	18000	13000	650	3/4	3/8	3/4	3/8	3/4	3/8	0.053	
	E*1P30(A,B,C)+45 SEC BLOWER DELAY	14	12.2	18000	13000	650	3/4	3/8	3/4	3/8	3/4	3/8	0.053	
	ED1P30/36+H4TXV01+45 SEC BLOWER TIME DELAY	14	12.2	18000	13000	600	3/4	3/8	3/4	3/8	3/4	3/8	0.053	
4AC16L24P-1	EC4X29(A,B)+45 SEC BLOWER DELAY	14.5	12.2	23000	17000	850	3/4	3/8	3/4	3/8	3/4	3/8	0.053	
	EC4X36(A,B,C)+45 SEC BLOWER DELAY	14.5	12.2	23000	17000	850	3/4	3/8	3/4	3/8	3/4	3/8	0.053	
	E*1P23(A,B)+TDR	14.25	12.2	23000	17000	850	3/4	3/8	3/4	3/8	3/4	3/8	0.053	
	E*1P36(A,B,C)+TDR	14.25	12.2	23000	17000	850	3/4	3/8	3/4	3/8	3/4	3/8	0.053	
	EC4X23(A,B)+45 SEC BLOWER DELAY	14.25	12.2	23000	17000	850	3/4	3/8	3/4	3/8	3/4	3/8	0.053	
	E*1P29(A,B)+TDR	14	12.2	23000	17000	850	3/4	3/8	3/4	3/8	3/4	3/8	0.053	
	E*1P30(A,B,C)+45 SEC BLOWER DELAY	14	12.2	23000	17000	750	3/4	3/8	3/4	3/8	3/4	3/8	0.053	
	ED1P30/36+H4TXV01+45 SEC BLOWER TIME DELAY	14	12.2	23000	17000	800	3/4	3/8	3/4	3/8	3/4	3/8	0.053	
4AC16L30P-1	EC4X43(B,C)+45 SEC BLOWER DELAY	14.5	12.2	28000	21000	1000	3/4	3/8	3/4	3/8	3/4	3/8	0.065	
	E*1P36(A,B,C)+TDR	14.25	12.2	28000	21000	1000	3/4	3/8	3/4	3/8	3/4	3/8	0.065	
	EC4X36(A,B,C)+45 SEC BLOWER DELAY	14.25	12.2	28000	21000	1000	3/4	3/8	3/4	3/8	3/4	3/8	0.065	

COOLING PERFORMANCE WITH EVAPORATOR COILS AC'S

Outdoor Model	Indoor Model	SEER	EER	AHRI Rated Capacity(1) BTUH	Rated Sensible BTUH	CFM	Refrigerant Connection				Refrigerant Line Set		Indoor Expansion Device	
							Outdoor		Indoor		Suction	Liquid	Piston(2)	TXV
	Suction						Liquid	Suction	Liquid					
	Evap. Coil(3)													
4AC16L36P-1	E*1P43(B,C)+TDR	14.5	12.2	34000	25500	1200	7/8	3/8	7/8	3/8	7/8	3/8	0.071	A4TXV01
	EC4X43(B,C)+45 SEC BLOWER DELAY	14.5	12.2	34000	25500	1200	7/8	3/8	7/8	3/8	7/8	3/8	0.071	
	EC4X49C+TDR	14.5	12.2	34000	25500	1200	7/8	3/8	7/8	3/8	7/8	3/8	0.071	
	EC4X48(B,C)+45 SEC BLOWER DELAY	14.5	12.2	34000	25500	1200	7/8	3/8	7/8	3/8	7/8	3/8	0.071	
	EC4X50C+45 SEC BLOWER DELAY	14.5	12.2	34000	25500	1200	7/8	3/8	7/8	3/8	7/8	3/8	0.071	
	E*1P36(B,C)+TDR	14.25	12.2	34000	25500	1200	7/8	3/8	7/8	3/8	7/8	3/8	0.071	
4AC16L41P-1	E(C,H,U)1P49C+TXV+TDR	14.5	12.2	38000	28000	1400	7/8	3/8	7/8	3/8	7/8	3/8		A4TXV02
E(C,H,U)1P62C+TXV+TDR	14.5	12.2	38000	28000	1400	7/8	3/8	7/8	3/8	7/8	3/8			
EC4X49C+TDR	14.5	12.2	38000	28000	1400	7/8	3/8	7/8	3/8	7/8	3/8			
EC4X62C+TDR	14.5	12.2	38000	28000	1400	7/8	3/8	7/8	3/8	7/8	3/8			
E*1P43(B,C)+H4TXV02+45 SEC BLOWER DELAY	14	12.2	37000	28000	1380	7/8	3/8	7/8	3/8	7/8	3/8			
4AC16L42P-1	E*1P49C+TDR+H4TXV02	14	12.2	40000	30000	1400	7/8	3/8	7/8	3/8	7/8	3/8		A4TXV02
	E*1P43(B,C)+TDR+H4TXV02	14	12.2	40000	30000	1400	7/8	3/8	7/8	3/8	7/8	3/8		
	EC4X62D+TDR	14	12.2	40000	30000	1400	7/8	3/8	7/8	3/8	7/8	3/8		
	EC4X62C+TDR	14	12.2	40000	30000	1400	7/8	3/8	7/8	3/8	7/8	3/8		
	EC4X49C+TDR	14	12.2	40000	30000	1400	7/8	3/8	7/8	3/8	7/8	3/8		
	EC4X43B,C+TDR	14	12.2	40000	30000	1400	7/8	3/8	7/8	3/8	7/8	3/8		
4AC16L47P-1	E*1P62D+TDR+H4TXV02	14	12.2	40000	30000	1400	7/8	3/8	7/8	3/8	7/8	3/8		A4TXV02
EC4X62C+TDR	14.5	11.7	46000	35000	1600	7/8	3/8	7/8	3/8	7/8	3/8			
EC4X62D+TDR	14.5	11.7	46000	35000	1600	7/8	3/8	7/8	3/8	7/8	3/8			
EC4X49C+TDR	14.5	11.7	46000	35000	1600	7/8	3/8	7/8	3/8	7/8	3/8			
EC4X43C+TDR	14.5	11.7	46000	35000	1600	7/8	3/8	7/8	3/8	7/8	3/8			
EC4X60D+TDR	14.5	11.7	46000	35000	1600	7/8	3/8	7/8	3/8	7/8	3/8			
E(C,H,U)1P62C+TXV+TDR	14	11.7	46000	35000	1600	7/8	3/8	7/8	3/8	7/8	3/8			
4AC16L48P-1	E(C,H,U)1P62D+TXV+TDR	14	11.7	46000	35000	1600	7/8	3/8	7/8	3/8	7/8	3/8		A4TXV02
E(C,H,U)1P49C+TXV+TDR	14	11.7	46000	35000	1600	7/8	3/8	7/8	3/8	7/8	3/8			
E*1P62C+TDR+H4TXV02	14.25	12	46500	34500	1600	7/8	3/8	7/8	3/8	7/8	3/8			
E*1P49C+TDR+H4TXV02	14	12	46500	34500	1600	7/8	3/8	7/8	3/8	7/8	3/8			
E*1P62D+TDR+H4TXV02	14	12	46500	34500	1600	7/8	3/8	7/8	3/8	7/8	3/8			
EC4X49C+TDR	14	12	46500	34500	1600	7/8	3/8	7/8	3/8	7/8	3/8			
EC4X62C+TDR	14	12	46500	34500	1600	7/8	3/8	7/8	3/8	7/8	3/8			
4AC16L59P-1	EC4X62D+TDR	14.5	12	58000	41500	1800	11/8	3/8	7/8	3/8	11/8	3/8		A4TXV02
EC4X60D+TDR	14.5	12	58000	41500	1800	11/8	3/8	7/8	3/8	11/8	3/8			
E*1P62C+TDR+H4TXV03	14.25	12	58000	41500	1800	11/8	3/8	7/8	3/8	11/8	3/8			
EC4X62C+TDR	14.25	12	58000	41500	1800	11/8	3/8	7/8	3/8	11/8	3/8			
E*1P62D+TDR+H4TXV03	14	12	58000	41500	1800	11/8	3/8	7/8	3/8	11/8	3/8			
ED1P60+H4TXV02+45 SEC BLOWER TIME DELAY	14	11.7	55500	41500	1750	11/8	3/8	7/8	3/8	11/8	3/8			
4AC16L60P-1	ED1P50/60+H4TXV02+45 SEC BLOWER TIME DELAY	14	11.7	55500	41500	1750	11/8	3/8	7/8	3/8	11/8	3/8		A4TXV02
EC4X62C+TDR	14.5	12	58000	42000	1800	11/8	3/8	7/8	3/8	11/8	3/8			
	E*1P62C+TDR+H4TXV03	14	12	58000	42000	1800	11/8	3/8	7/8	3/8	11/8	3/8		

Note:

¹ Certified in accordance with Unitary Air Conditioner Certification Program, which is based on AHRI Standard 210/240

² Required to achieve AHRI rating. If NA (Not Applicable) is in the piston column, then TXV is required.

³ A blower time delay relay is required to achieve AHRI rating. This feature is standard on all Allied Air Enterprises furnace and AH products.

COOLING PERFORMANCE WITH EVAPORATOR COILS AC'S

Outdoor Model	Indoor Model	SEER	EER	AHRI Rated Capacity(1) BTUH	Rated Sensible BTUH	CFM	Refrigerant Connection				Refrigerant Line Set		Indoor Expansion Device	
							Outdoor		Indoor		Suction	Liquid	Piston(2)	TXV
	Suction						Liquid	Suction	Liquid					
	Evap. Coil(3)													
4AC16LR18P-1	EC4X29(A,B)+45 SEC BLOWER DELAY	14.5	12.2	18000	13000	650	3/4	3/8	3/4	3/8	3/4	3/8	0.053	
	E*1P29(A,B)+TDR	14.25	12.2	18000	13000	650	3/4	3/8	3/4	3/8	3/4	3/8	0.053	
	E*1P36(A,B,C)+TDR	14.25	12.2	18000	13000	650	3/4	3/8	3/4	3/8	3/4	3/8	0.053	
	EC4X36(A,B,C)+45 SEC BLOWER DELAY	14.25	12.2	18000	13000	650	3/4	3/8	3/4	3/8	3/4	3/8	0.053	
	E*1P23(A,B)+TDR	14	12.2	18000	13000	650	3/4	3/8	3/4	3/8	3/4	3/8	0.053	
	EC4X23(A,B)+45 SEC BLOWER DELAY	14	12.2	18000	13000	650	3/4	3/8	3/4	3/8	3/4	3/8	0.053	
	EDIP30/36+H4TXV01+45 SEC BLOWER TIME DELAY	14	12.2	18000	13000	600	3/4	3/8	3/4	3/8	3/4	3/8	0.053	
4AC16LR24P-1	EC4X29(A,B)+45 SEC BLOWER DELAY	14.5	12.2	23000	17000	850	3/4	3/8	3/4	3/8	3/4	3/8	0.053	
	EC4X36(A,B,C)+45 SEC BLOWER DELAY	14.5	12.2	23000	17000	850	3/4	3/8	3/4	3/8	3/4	3/8	0.053	
	E*1P36(A,B,C)+TDR	14.25	12.2	23000	17000	850	3/4	3/8	3/4	3/8	3/4	3/8	0.053	
	E*1P23(A,B)+TDR	14	12.2	23000	17000	850	3/4	3/8	3/4	3/8	3/4	3/8	0.053	
	E*1P29(A,B)+TDR	14	12.2	23000	17000	850	3/4	3/8	3/4	3/8	3/4	3/8	0.053	
	E*1P30(A,B,C)+TDR	14	11.5	23000	17000	850	3/4	3/8	3/4	3/8	3/4	3/8	0.053	
	EC4X23(A,B)+45 SEC BLOWER DELAY	14	12.2	23000	17000	850	3/4	3/8	3/4	3/8	3/4	3/8	0.053	
	EC4X30(A,B,C)+45 SEC BLOWER DELAY	14	11.5	23000	17000	850	3/4	3/8	3/4	3/8	3/4	3/8	0.053	
EDIP30/36+H4TXV01+45 SEC BLOWER TIME DELAY	14	12.2	23000	17000	800	3/4	3/8	3/4	3/8	3/4	3/8	0.053		
4AC16LR30P-1	EC4X36(A,B,C)+45 SEC BLOWER DELAY	14.5	12.2	28000	21000	1000	3/4	3/8	3/4	3/8	3/4	3/8	0.065	
	EC4X43(B,C)+45 SEC BLOWER DELAY	14.5	12.2	28000	21000	1000	3/4	3/8	3/4	3/8	3/4	3/8	0.065	
	E*1P36(B,C)+TDR	14	12.2	28000	21000	1000	3/4	3/8	3/4	3/8	3/4	3/8	0.065	
	E*1P36(A,B,C)+TDR	14	12.2	28000	21000	1000	3/4	3/8	3/4	3/8	3/4	3/8	0.065	
	EC4X36(B,C)+45 SEC BLOWER DELAY	14	12.2	28000	21000	1000	3/4	3/8	3/4	3/8	3/4	3/8	0.065	
4AC16LR36P-1	E*1P43(B,C)+TDR	14.5	12.2	34000	25500	1200	7/8	3/8	7/8	3/8	7/8	3/8	0.071	
	EC4X43(B,C)+45 SEC BLOWER DELAY	14.5	12.2	34000	25500	1200	7/8	3/8	7/8	3/8	7/8	3/8	0.071	
	EC4X49C+TDR	14.5	12.2	34000	25500	1200	7/8	3/8	7/8	3/8	7/8	3/8	0.071	
	EC4X48(B,C)+45 SEC BLOWER DELAY	14.5	12.2	34000	25500	1200	7/8	3/8	7/8	3/8	7/8	3/8	0.071	
	EC4X50C+45 SEC BLOWER DELAY	14.5	12.2	34000	25500	1200	7/8	3/8	7/8	3/8	7/8	3/8	0.071	
	E*1P36(B,C)+TDR	14.25	12.2	34000	25500	1200	7/8	3/8	7/8	3/8	7/8	3/8	0.071	
	EC4X36(B,C)+45 SEC BLOWER DELAY	14	12.2	34000	25500	1200	7/8	3/8	7/8	3/8	7/8	3/8	0.071	
4AC16LR42P-1	E*1P49C+TDR+H4TXV02	14	12	40000	30000	1400	7/8	3/8	7/8	3/8	7/8	3/8		
	E*1P43(B,C)+TDR+H4TXV02	14	12	40000	30000	1400	7/8	3/8	7/8	3/8	7/8	3/8		
	E*1P62C+TDR+H4TXV02	14	12	40000	30000	1400	7/8	3/8	7/8	3/8	7/8	3/8		
	EC4X43B,C+TDR	14	12	40000	30000	1400	7/8	3/8	7/8	3/8	7/8	3/8		
	EC4X62C+TDR	14	12	40000	30000	1400	7/8	3/8	7/8	3/8	7/8	3/8		
	EC4X49C+TDR	14	12	40000	30000	1400	7/8	3/8	7/8	3/8	7/8	3/8		

A4TXV01

A4TXV02

Note:

¹ Certified in accordance with Unitary Air Conditioner Certification Program, which is based on AHRI Standard 210/240

² Required to achieve AHRI rating. If NA (Not Applicable) is in the piston column, then TXV is required.

³ A blower time delay relay is required to achieve AHRI rating. This feature is standard on all Allied Air Enterprises furnace and AH products.

COOLING PERFORMANCE WITH AIR HANDLERS AND FURNACES

Outdoor Unit	Indoor Model	Furnace Model	SEER	EER	AHRI Rated Capacity BTUH	Sensible Capacity	CFM
	Evap Coil						
4AC16L18P-1	BCE3M24E****4X		16	13	18000	13000	650
	BCE3M24V****4X		16	13	18000	13000	650
	BCE3M18V****4X		14.5	12.2	18000	13000	600
	E*1P23A	80G1UH045AE12	16	13	18000	13000	650
	E*1P23A	80G2UH070AV12	16	13	18000	13000	650
	E*1P23A+H4TXV01	A80US2V070A12L	16	13	18000	13000	650
	E*1P23B	80G2UH090BV16	16	13	18000	13000	620
	E*1P23B	95G2UH045BV12	16	13	18000	13000	650
	E*1P23B	95G2UH070BV12	16	13	18000	13000	650
	E*1P23B	EFV08BC	16	13	18000	13000	650
	E*1P23B+TXV	95G1UH045BE12	16	13	18000	13000	635
	E*1P23B+TXV	95G2UH045BE12	16	13	18000	13000	635
	E*1P24A	80G2UH070AV12	16	13	18000	13000	650
	E*1P24B	80G2UH090BV16	16	13	18000	13000	620
	E*1P24B	95G2UH070BV12	16	13	18000	13000	650
	E*1P29A	80G1UH045AE12	16	13	18000	13000	650
	E*1P29A	80G2UH070AV12	16	13	18000	13000	650
	E*1P29B	80G2UH090BV16	16	13	18000	13000	620
	E*1P29B	95G2UH045BV12	16	13	18000	13000	650
	E*1P29B	95G2UH070BV12	16	13	18000	13000	650
	E*1P29B+TXV	95G1UH045BE12	16	13	18000	13000	635
	E*1P29B+TXV	95G2UH045BE12	16	13	18000	13000	635
	E*1P30A	80G1UH045AE12	16	13	18000	13000	650
	E*1P30A	80G2UH070AV12	16	13	18000	13000	650
	E*1P30B	80G2UH090BV16	16	13	18000	13000	620
	E*1P30B	95G2UH045BV12	16	13	18000	13000	650
	E*1P30B	95G2UH070BV12	16	13	18000	13000	650
	E*1P30C	95G2UH090CV12	16	13	18000	13000	650
	E*1P36A	80G1UH045AE12	16	13	18000	13000	650
	E*1P36A	80G2UH070AV12	16	13	18000	13000	650
	E*1P36B	80G2UH090BV16	16	13	18000	13000	620
	E*1P36B	95G2UH045BV12	16	13	18000	13000	650
	E*1P36B	95G2UH070BV12	16	13	18000	13000	650
	E*1P36C	95G2UH090CV12	16	13	18000	13000	650
	EC4X23A	80G1UH045AE12	16	13	18000	13000	650
	EC4X23A	80G2UH070AV12	16	13	18000	13000	650
	EC4X23A	A80US2V070A12L	16	13	18000	13000	650
	EC4X23B	80G2UH090BV16	16	13	18000	13000	620
	EC4X23B	95G1UH045BE12	16	13	18000	13000	635
	EC4X23B	95G2UH045BE12	16	13	18000	13000	635

Note:

1 Certified in accordance with Unitary Air Conditioner Certification Program, which is based on AHRI Standard 210/240

2 Required to achieve AHRI rating. If NA (Not Applicable) is in the piston column, then TXV is required

3 A blower time delay relay is required to achieve AHRI rating. This feature is standard on all Allied Air Enterprises furnace and AH products.

COOLING PERFORMANCE WITH AIR HANDLERS AND FURNACES

Outdoor Unit	Indoor Model	Furnace Model	SEER	EER	AHRI Rated Capacity BTUH	Sensible Capacity	CFM
	Evap Coil						
4AC16L18P-1	EC4X23B	95G2UH045BV12	16	13	18000	13000	650
	EC4X23B	95G2UH070BV12	16	13	18000	13000	650
	EC4X23B	EFV08BC	16	13	18000	13000	650
	EC4X24A	80G2UH070AV12	16	13	18000	13000	650
	EC4X24B	80G2UH090BV16	16	13	18000	13000	620
	EC4X24B	95G2UH070BV12	16	13	18000	13000	650
	EC4X29A	80G1UH045AE12	16	13	18000	13000	650
	EC4X29A	80G2UH070AV12	16	13	18000	13000	650
	EC4X29B	80G2UH090BV16	16	13	18000	13000	620
	EC4X29B	95G1UH045BE12	16	13	18000	13000	635
	EC4X29B	95G2UH045BE12	16	13	18000	13000	635
	EC4X29B	95G2UH045BV12	16	13	18000	13000	650
	EC4X29B	95G2UH070BV12	16	13	18000	13000	650
	EC4X30A	80G1UH045AE12	16	13	18000	13000	650
	EC4X30A	80G2UH070AV12	16	13	18000	13000	650
	EC4X30B	80G2UH090BV16	16	13	18000	13000	620
	EC4X30B	95G2UH045BV12	16	13	18000	13000	650
	EC4X30B	95G2UH070BV12	16	13	18000	13000	650
	EC4X30C	95G2UH090CV12	16	13	18000	13000	650
	EC4X36A	80G1UH045AE12	16	13	18000	13000	650
	EC4X36A	80G2UH070AV12	16	13	18000	13000	650
	EC4X36B	80G2UH090BV16	16	13	18000	13000	620
	EC4X36B	95G2UH045BV12	16	13	18000	13000	650
	EC4X36B	95G2UH070BV12	16	13	18000	13000	650
	EC4X36C	95G2UH090CV12	16	13	18000	13000	650
	E*1P23B	80G1UH070BE12	15.1	13	18000	13000	650
	E*1P23B	95G1UH045BE12	15.1	13	18000	13000	650
	E*1P23B	95G1UH070BE12	15.1	13	18000	13000	650
	E*1P23B	95G2UH045BE12	15.1	13	18000	13000	620
	E*1P23B	95G2UH070BE12	15.1	13	18000	13000	650
	E*1P24A	80G1UH045AE12	15.1	13	18000	13000	650
	E*1P24B	80G1UH070BE12	15.1	13	18000	13000	620
	E*1P24B	95G1UH045BE12	15.1	13	18000	13000	620
	E*1P24B	95G2UH045BE12	15.1	13	18000	13000	620
	E*1P24B	95G2UH045BV12	15.1	13	18000	13000	650
	E*1P24B	EFV08BC	15.1	13	18000	13000	650
E*1P24B+TXV	95G1UH045BE12	15.1	12.5	18000	13000	635	
E*1P24B+TXV	95G2UH045BE12	15.1	12.5	18000	13000	635	
E*1P29B	80G1UH070BE12	15.1	13	18000	13000	620	
E*1P29B	95G1UH045BE12	15.1	13	18000	13000	620	

Note:

1 Certified in accordance with Unitary Air Conditioner Certification Program, which is based on AHRI Standard 210/240

2 Required to achieve AHRI rating. If NA (Not Applicable) is in the piston column, then TXV is required

3 A blower time delay relay is required to achieve AHRI rating. This feature is standard on all Allied Air Enterprises furnace and AH products.

COOLING PERFORMANCE WITH AIR HANDLERS AND FURNACES

Outdoor Unit	Indoor Model	Furnace Model	SEER	EER	AHRI Rated Capacity BTUH	Sensible Capacity	CFM
	Evap Coil						
4AC16L18P-1	E*1P29B	95G1UH070BE12	15.1	13	18000	13000	650
	E*1P29B	95G2UH045BE12	15.1	13	18000	13000	620
	E*1P29B	95G2UH070BE12	15.1	13	18000	13000	650
	E*1P29B	EFV08BC	15.1	13	18000	13000	650
	E*1P30B	80G1UH070BE12	15.1	13	18000	13000	620
	E*1P30B	95G1UH045BE12	15.1	13	18000	13000	620
	E*1P30B	95G1UH070BE12	15.1	13	18000	13000	650
	E*1P30B	95G2UH045BE12	15.1	13	18000	13000	620
	E*1P30B	95G2UH070BE12	15.1	13	18000	13000	650
	E*1P30B	EFV08BC	15.1	13	18000	13000	650
	E*1P36B	80G1UH070BE12	15.1	13	18000	13000	620
	E*1P36B	95G1UH045BE12	15.1	13	18000	13000	620
	E*1P36B	95G1UH070BE12	15.1	13	18000	13000	650
	E*1P36B	95G2UH045BE12	15.1	13	18000	13000	620
	E*1P36B	95G2UH070BE12	15.1	13	18000	13000	650
	E*1P36B	EFV08BC	15.1	13	18000	13000	650
	EC4X23B	80G1UH070BE12	15.1	13	18000	13000	650
	EC4X23B	95G1UH070BE12	15.1	13	18000	13000	650
	EC4X23B	95G2UH070BE12	15.1	13	18000	13000	650
	EC4X24A	80G1UH045AE12	15.1	13	18000	13000	650
	EC4X24B	80G1UH070BE12	15.1	13	18000	13000	620
	EC4X24B	95G1UH045BE12	15.1	12.5	18000	13000	635
	EC4X24B	95G2UH045BE12	15.1	12.5	18000	13000	635
	EC4X24B	95G2UH045BV12	15.1	13	18000	13000	650
	EC4X24B	EFV08BC	15.1	13	18000	13000	650
	EC4X29B	80G1UH070BE12	15.1	13	18000	13000	620
	EC4X29B	95G1UH070BE12	15.1	13	18000	13000	650
	EC4X29B	95G2UH070BE12	15.1	13	18000	13000	650
	EC4X29B	EFV08BC	15.1	13	18000	13000	650
	EC4X30B	80G1UH070BE12	15.1	13	18000	13000	620
	EC4X30B	95G1UH045BE12	15.1	13	18000	13000	620
	EC4X30B	95G1UH070BE12	15.1	13	18000	13000	650
	EC4X30B	95G2UH045BE12	15.1	13	18000	13000	620
	EC4X30B	95G2UH070BE12	15.1	13	18000	13000	650
	EC4X30B	EFV08BC	15.1	13	18000	13000	650
	EC4X36B	80G1UH070BE12	15.1	13	18000	13000	620
EC4X36B	95G1UH045BE12	15.1	13	18000	13000	620	
EC4X36B	95G1UH070BE12	15.1	13	18000	13000	650	
EC4X36B	95G2UH045BE12	15.1	13	18000	13000	620	
EC4X36B	95G2UH070BE12	15.1	13	18000	13000	650	

Note:

1 Certified in accordance with Unitary Air Conditioner Certification Program, which is based on AHRI Standard 210/240

2 Required to achieve AHRI rating. If NA (Not Applicable) is in the piston column, then TXV is required

3 A blower time delay relay is required to achieve AHRI rating. This feature is standard on all Allied Air Enterprises furnace and AH products.

COOLING PERFORMANCE WITH AIR HANDLERS AND FURNACES

Outdoor Unit	Indoor Model	Furnace Model	SEER	EER	AHRI Rated Capacity BTUH	Sensible Capacity	CFM
	Evap Coil						
4AC16L18P-1	EC4X36B	EFV08BC	15.1	13	18000	13000	650
	E*1P24B	95G1UH070BE12	14.5	12.2	18000	13000	650
	E*1P24B	95G2UH070BE12	14.5	12.2	18000	13000	650
	EC4X24B	95G1UH070BE12	14.5	12.2	18000	13000	650
	EC4X24B	95G2UH070BE12	14.5	12.2	18000	13000	650
	BCE3M18C****P		14	12.2	18000	13000	650
	ED1P18A+H4TXV01	80G1DF045AE12	14	12.2	18000	13000	625
	ED1P24A+H4TXV01	80G1DF045AE12	14	12.2	18000	13000	625
	ED1P24B+H4TXV01	80G1DF070BE12	14	12.2	18000	13000	645
4AC16L24P-1	BCE3M24V****4X		16	13	23000	17000	820
	BCE3M30V****4X		16	13	23000	17000	800
	BCE3M36E****4X		16	13	23000	17000	850
	BCE3M36V****4X		16	13	23000	17000	820
	BCE3M24E****4X		15.1	12.5	23000	17000	850
	BCE3M30E****4X		15.1	13	23000	17000	850
	BCE3M24C****P		14	12.2	23000	17000	850
	E*1P23A	80G1UH045AE12	16	13	23000	17000	850
	E*1P23A+H4TXV01	A80US2V070A12L	16	13	23000	17000	850
	E*1P23B	95G2UH045BV12	16	13	23000	17000	850
	E*1P23B	95G2UH070BE12	16	13	23000	17000	800
	E*1P23B+H4TXV01	A80US2V090B16L	16	13	23000	17000	850
	E*1P23B+TXV	95G1UH045BE12	16	13	23000	17000	785
	E*1P23B+TXV	95G1UH070BE12	16	13	23000	17000	835
	E*1P23B+TXV	95G2UH070BE12	16	13	23000	17000	835
	E*1P24A	80G2UH070AV12	16	13	23000	17000	850
	E*1P24B	80G1UH070BE12	16	13	23000	17000	800
	E*1P29B	95G1UH070BE12	16	13	23000	17000	800
	E*1P29B+TXV	95G1UH045BE12	16	13	23000	17000	785
	E*1P29B+TXV	95G1UH070BE12	16	13	23000	17000	835
	E*1P29B+TXV	95G2UH070BE12	16	13	23000	17000	835
	E*1P30B	80G2UH090BV16	16	13	23000	17000	800
	E*1P30B	95G2UH045BV12	16	13	23000	17000	850
	E*1P36A	80G2UH070AV12	16	13	23000	17000	850
	E*1P36B	95G1UH045BE12	16	13	23000	17000	760
	E*1P36B	95G2UH070BV12	16	13	23000	17000	850
	E*1P36B+TXV	95G1UH045BE12	16	13	23000	17000	785
	E*1P36B+TXV	95G1UH070BE12	16	13	23000	17000	835
	E*1P36B+TXV	95G2UH045BE12	16	13	23000	17000	785
	E*1P36B+TXV	95G2UH070BE12	16	13	23000	17000	835
E*1P36C	95G2UH090CV12	16	13	23000	17000	850	

Note:

1 Certified in accordance with Unitary Air Conditioner Certification Program, which is based on AHRI Standard 210/240

2 Required to achieve AHRI rating. If NA (Not Applicable) is in the piston column, then TXV is required

3 A blower time delay relay is required to achieve AHRI rating. This feature is standard on all Allied Air Enterprises furnace and AH products.

COOLING PERFORMANCE WITH AIR HANDLERS AND FURNACES

Outdoor Unit	Indoor Model		SEER	EER	AHRI Rated Capacity BTUH	Sensible Capacity	CFM
	Evap Coil	Furnace Model					
4AC16L24P-1	EC4X23A	80G1UH045AE12	16	13	23000	17000	850
	EC4X23A	A80US2V070A12L	16	13	23000	17000	850
	EC4X23B	95G1UH045BE12	16	13	23000	17000	785
	EC4X23B	95G1UH070BE12	16	13	23000	17000	835
	EC4X23B	95G2UH045BV12	16	13	23000	17000	850
	EC4X23B	95G2UH070BE12	16	13	23000	17000	835
	EC4X23B	A80US2V090B16L	16	13	23000	17000	850
	EC4X24A	80G2UH070AV12	16	13	23000	17000	850
	EC4X24B	80G1UH070BE12	16	13	23000	17000	800
	EC4X29B	95G1UH045BE12	16	13	23000	17000	785
	EC4X29B	95G1UH070BE12	16	13	23000	17000	835
	EC4X29B	95G2UH070BE12	16	13	23000	17000	835
	EC4X30B	80G2UH090BV16	16	13	23000	17000	800
	EC4X30B	95G2UH045BV12	16	13	23000	17000	850
	EC4X36A	80G2UH070AV12	16	13	23000	17000	850
	EC4X36B	95G1UH045BE12	16	13	23000	17000	785
	EC4X36B	95G1UH070BE12	16	13	23000	17000	835
	EC4X36B	95G2UH045BE12	16	13	23000	17000	785
	EC4X36B	95G2UH070BE12	16	13	23000	17000	835
	EC4X36B	95G2UH070BV12	16	13	23000	17000	850
	EC4X36C	95G2UH090CV12	16	13	23000	17000	850
	E*1P24B+TXV	95G1UH070BE12	15.5	12.5	23000	17000	795
	E*1P24B+TXV	95G2UH070BE12	15.5	12.5	23000	17000	795
	E*1P30B+TXV	95G1UH045BE12	15.5	12.5	23000	17000	785
	EC4X24B	95G1UH070BE12	15.5	12.5	23000	17000	795
	EC4X24B	95G2UH070BE12	15.5	12.5	23000	17000	795
	EC4X30B	95G1UH045BE12	15.5	12.5	23000	17000	785
	E*1P23A	80G2UH070AV12	15.1	13	23000	17000	850
	E*1P23B	80G1UH070BE12	15.1	13	23000	17000	800
	E*1P23B	80G2UH090BV16	15.1	12.5	23000	17000	800
	E*1P23B	95G1UH045BE12	15.1	13	23000	17000	760
	E*1P23B	95G1UH070BE12	15.1	12.5	23000	17000	800
	E*1P23B	95G2UH070BV12	15.1	13	23000	17000	850
	E*1P23B	EFV08BC	15.1	12.5	23000	17000	850
E*1P24B	95G1UH045BE12	15.1	13	23000	17000	760	
E*1P24B+TXV	95G1UH045BE12	15.1	12.5	23000	17000	735	
E*1P29A	80G1UH045AE12	15.1	13	23000	17000	850	
E*1P29A	80G2UH070AV12	15.1	13	23000	17000	850	
E*1P29B	80G1UH070BE12	15.1	13	23000	17000	800	
E*1P29B	80G2UH090BV16	15.1	13	23000	17000	800	

Note:

1 Certified in accordance with Unitary Air Conditioner Certification Program, which is based on AHRI Standard 210/240

2 Required to achieve AHRI rating. If NA (Not Applicable) is in the piston column, then TXV is required

3 A blower time delay relay is required to achieve AHRI rating. This feature is standard on all Allied Air Enterprises furnace and AH products.

COOLING PERFORMANCE WITH AIR HANDLERS AND FURNACES

Outdoor Unit	Indoor Model	Furnace Model	SEER	EER	AHRI Rated Capacity BTUH	Sensible Capacity	CFM
	Evap Coil						
4AC16L24P-1	E*1P29B	95G1UH045BE12	15.1	13	23000	17000	760
	E*1P29B	95G2UH045BV12	15.1	13	23000	17000	850
	E*1P29B	95G2UH070BE12	15.1	13	23000	17000	800
	E*1P29B	95G2UH070BV12	15.1	13	23000	17000	850
	E*1P29B	EFV08BC	15.1	12.5	23000	17000	850
	E*1P30A	80G1UH045AE12	15.1	12.5	23000	17000	850
	E*1P30A	80G2UH070AV12	15.1	13	23000	17000	850
	E*1P30B	80G1UH070BE12	15.1	13	23000	17000	800
	E*1P30B	95G1UH045BE12	15.1	13	23000	17000	760
	E*1P30B	95G1UH070BE12	15.1	13	23000	17000	800
	E*1P30B	95G2UH070BE12	15.1	12.5	23000	17000	800
	E*1P30B	95G2UH070BV12	15.1	12.5	23000	17000	850
	E*1P30C	95G2UH090CV12	15.1	13	23000	17000	850
	E*1P36A	80G1UH045AE12	15.1	13	23000	17000	850
	E*1P36B	80G1UH070BE12	15.1	13	23000	17000	820
	E*1P36B	80G2UH090BV16	15.1	13	23000	17000	800
	E*1P36B	95G1UH070BE12	15.1	13	23000	17000	800
	E*1P36B	95G2UH045BV12	15.1	13	23000	17000	850
	E*1P36B	95G2UH070BE12	15.1	13	23000	17000	800
	E*1P36B	EFV08BC	15.1	13	23000	17000	850
	EC4X23A	80G2UH070AV12	15.1	13	23000	17000	850
	EC4X23B	80G1UH070BE12	15.1	13	23000	17000	800
	EC4X23B	80G2UH090BV16	15.1	12.5	23000	17000	800
	EC4X23B	95G2UH070BV12	15.1	13	23000	17000	850
	EC4X23B	EFV08BC	15.1	12.5	23000	17000	850
	EC4X24B	95G1UH045BE12	15.1	12.5	23000	17000	735
	EC4X29A	80G1UH045AE12	15.1	13	23000	17000	850
	EC4X29A	80G2UH070AV12	15.1	13	23000	17000	850
	EC4X29B	80G1UH070BE12	15.1	13	23000	17000	800
	EC4X29B	80G2UH090BV16	15.1	13	23000	17000	800
	EC4X29B	95G2UH045BV12	15.1	13	23000	17000	850
	EC4X29B	95G2UH070BV12	15.1	13	23000	17000	850
	EC4X29B	EFV08BC	15.1	12.5	23000	17000	850
	EC4X30A	80G1UH045AE12	15.1	12.5	23000	17000	850
	EC4X30A	80G2UH070AV12	15.1	13	23000	17000	850
	EC4X30B	80G1UH070BE12	15.1	13	23000	17000	800
EC4X30B	95G1UH070BE12	15.1	13	23000	17000	800	
EC4X30B	95G2UH070BE12	15.1	12.5	23000	17000	800	
EC4X30B	95G2UH070BV12	15.1	12.5	23000	17000	850	
EC4X30C	95G2UH090CV12	15.1	13	23000	17000	850	

Note:

1 Certified in accordance with Unitary Air Conditioner Certification Program, which is based on AHRI Standard 210/240

2 Required to achieve AHRI rating. If NA (Not Applicable) is in the piston column, then TXV is required

3 A blower time delay relay is required to achieve AHRI rating. This feature is standard on all Allied Air Enterprises furnace and AH products.

COOLING PERFORMANCE WITH AIR HANDLERS AND FURNACES

Outdoor Unit	Indoor Model		SEER	EER	AHRI Rated Capacity BTUH	Sensible Capacity	CFM
	Evap Coil	Furnace Model					
4AC16L24P-1	EC4X36A	80G1UH045AE12	15.1	13	23000	17000	850
	EC4X36B	80G1UH070BE12	15.1	13	23000	17000	820
	EC4X36B	80G2UH090BV16	15.1	13	23000	17000	800
	EC4X36B	95G2UH045BV12	15.1	13	23000	17000	850
	EC4X36B	EFV08BC	15.1	13	23000	17000	850
	ED1P24A+H4TXV01	80G1DF045AE12	15	12.5	23000	17000	835
	ED1P24B+H4TXV01	80G1DF070BE12	15	12.5	23000	17000	755
	ED1P24B+H4TXV01	95G1DF045BE12	15	12.5	22000	17000	730
	ED1P24B+H4TXV01	95G1DF070BE16	15	12.5	22000	17000	740
	ED1P24B+H4TXV01	95G2DF045BE12	15	12.5	22000	17000	730
	ED1P24B+H4TXV01	95G2DF045BV12	15	12.5	23000	17000	805
	ED1P24B+H4TXV01	95G2DF070BE16	15	12.5	22000	17000	740
	ED1P24B+H4TXV01	95G2DF070BV16	15	12.5	23000	17000	860
	ED1P30/36A+H4TXV01	80G1DF045AE12	15	12.5	24000	17000	835
	ED1P30/36B+H4TXV01	80G1DF070BE12	15	12.5	24000	17000	790
	ED1P30/36B+H4TXV01	95G1DF045BE12	15	12.5	24000	17000	735
	ED1P30/36B+H4TXV01	95G1DF070BE16	15	12.5	24000	17000	775
	ED1P30/36B+H4TXV01	95G2DF045BE12	15	12.5	24000	17000	735
	ED1P30/36B+H4TXV01	95G2DF045BV12	15	12.5	24000	17000	805
	ED1P30/36B+H4TXV01	95G2DF070BE16	15	12.5	24000	17000	775
	ED1P30/36B+H4TXV01	95G2DF070BV16	15	12.5	24000	17000	880
	E*1P24A	80G1UH045AE12	14.5	12.2	23000	17000	850
	E*1P24B	80G2UH090BV16	14.5	12.2	23000	17000	800
	E*1P24B	95G1UH070BE12	14.5	12.2	23000	17000	800
	E*1P24B	95G2UH045BV12	14.5	12.25	23000	17000	850
	E*1P24B	95G2UH070BE12	14.5	12.2	23000	17000	800
	E*1P24B	95G2UH070BV12	14.5	12.25	23000	17000	850
	E*1P24B	EFV08BC	14.5	12.2	23000	17000	850
	E*1P30B	EFV08BC	14.5	12.2	23000	17000	850
	EC4X24A	80G1UH045AE12	14.5	12.2	23000	17000	850
	EC4X24B	80G2UH090BV16	14.5	12.2	23000	17000	800
	EC4X24B	95G2UH045BV12	14.5	12.25	23000	17000	850
	EC4X24B	95G2UH070BV12	14.5	12.25	23000	17000	850
	EC4X24B	EFV08BC	14.5	12.2	23000	17000	850
	EC4X30B	EFV08BC	14.5	12.2	23000	17000	850
	E*1P36B	95G2UH045BE12	14	12.2	23000	17000	850

Note:

1 Certified in accordance with Unitary Air Conditioner Certification Program, which is based on AHRI Standard 210/240

2 Required to achieve AHRI rating. If NA (Not Applicable) is in the piston column, then TXV is required

3 A blower time delay relay is required to achieve AHRI rating. This feature is standard on all Allied Air Enterprises furnace and AH products.

COOLING PERFORMANCE WITH AIR HANDLERS AND FURNACES

Outdoor Unit	Indoor Model	Furnace Model	SEER	EER	AHRI Rated Capacity BTUH	Sensible Capacity	CFM
	Evap Coil						
4AC16L30P-1	BCE3M30E****4X		15.1	13	28000	21000	1000
	BCE3M30C****P		14	12.2	28000	21000	1000
	E*1P36B	80G2UH090BV16	16	13	28000	21000	1000
	E*1P36B	95G2UH070BV12	16	13	28000	21000	960
	E*1P36C	95G2UH090CE16	16	13	28000	21000	1000
	E*1P36C	95G2UH090CV12	16	13	28000	21000	1000
	E*1P43C+TXV	95G1UH090CE16	16	13	28000	21000	945
	E*1P43C+TXV	95G2UH090CE16	16	13	28000	21000	945
	EC4X36B	80G2UH090BV16	16	13	28000	21000	1000
	EC4X36B	95G2UH070BV12	16	13	28000	21000	960
	EC4X36C	95G2UH090CE16	16	13	28000	21000	1000
	EC4X36C	95G2UH090CV12	16	13	28000	21000	1000
	EC4X43C	95G1UH090CE16	16	13	28000	21000	945
	EC4X43C	95G2UH090CE16	16	13	28000	21000	945
	E*1P29B+TXV	95G1UH045BE12	15.5	12.5	28000	21000	1015
	E*1P29B+TXV	95G2UH045BE12	15.5	12.5	28000	21000	1015
	E*1P36B+TXV	95G1UH045BE12	15.5	12.5	28000	21000	1015
	E*1P36B+TXV	95G1UH070BE12	15.5	12.5	28000	21000	1045
	E*1P36B+TXV	95G2UH045BE12	15.5	12.5	28000	21000	1015
	E*1P36B+TXV	95G2UH070BE12	15.5	12.5	28000	21000	1045
	EC4X29B	95G1UH045BE12	15.5	12.5	28000	21000	1015
	EC4X29B	95G2UH045BE12	15.5	12.5	28000	21000	1015
	EC4X36B	95G1UH045BE12	15.5	12.5	28000	21000	1015
	EC4X36B	95G1UH070BE12	15.5	12.5	28000	21000	1045
	EC4X36B	95G2UH045BE12	15.5	12.5	28000	21000	1015
	EC4X36B	95G2UH070BE12	15.5	12.5	28000	21000	1045
	E*1P29A	80G1UH045AE12	15.1	13	28000	21000	1000
	E*1P29A	80G2UH070AV12	15.1	13	28000	21000	1000
	E*1P29B	80G1UH070BE12	15.1	13	28000	21000	1000
	E*1P29B	80G1UH090BE16	15.1	13	28000	21000	1000
	E*1P29B	80G2UH090BV16	15.1	13	28000	21000	1000
	E*1P29B	95G1UH045BE12	15.1	13	28000	21000	1000
	E*1P29B	95G1UH070BE12	15.1	13	28000	21000	1000
	E*1P29B	95G2UH045BE12	15.1	13	28000	21000	1000
	E*1P29B	95G2UH045BV12	15.1	13	28000	21000	980
	E*1P29B	95G2UH070BE12	15.1	13	28000	21000	1000
	E*1P29B	95G2UH070BV12	15.1	13	28000	21000	960
	E*1P29B+TXV	95G1UH070BE12	15.1	12.5	28000	21000	995
	E*1P29B+TXV	95G2UH070BE12	15.1	12.5	28000	21000	995
	E*1P30C	95G2UH090CE16	15.1	13	28000	21000	1040

Note:

1 Certified in accordance with Unitary Air Conditioner Certification Program, which is based on AHRI Standard 210/240

2 Required to achieve AHRI rating. If NA (Not Applicable) is in the piston column, then TXV is required

3 A blower time delay relay is required to achieve AHRI rating. This feature is standard on all Allied Air Enterprises furnace and AH products.

COOLING PERFORMANCE WITH AIR HANDLERS AND FURNACES

Outdoor Unit	Indoor Model	Furnace Model	SEER	EER	AHRI Rated Capacity BTUH	Sensible Capacity	CFM
	Evap Coil						
4AC16L30P-1	E*1P36A	80G1UH045AE12	15.1	13	28000	21000	1000
	E*1P36A	80G2UH070AV12	15.1	13	28000	21000	1000
	E*1P36B	80G1UH070BE12	15.1	13	28000	21000	1000
	E*1P36B	80G1UH090BE16	15.1	13	28000	21000	1000
	E*1P36B	95G1UH045BE12	15.1	13	28000	21000	1000
	E*1P36B	95G1UH070BE12	15.1	13	28000	21000	1000
	E*1P36B	95G2UH045BE12	15.1	13	28000	21000	1015
	E*1P36B	95G2UH045BV12	15.1	13	28000	21000	980
	E*1P36B	95G2UH070BE12	15.1	13	28000	21000	995
	E*1P36B+H4TXV01	A80US2V090B16L	15.1	13	28000	21000	1000
	E*1P36C	95G1UH090CE16	15.1	13	28000	21000	1000
	E*1P48C	95G1UH090CE16	15.1	13	28000	21000	1000
	EC4X29A	80G1UH045AE12	15.1	13	28000	21000	1000
	EC4X29A	80G2UH070AV12	15.1	13	28000	21000	1000
	EC4X29B	80G1UH070BE12	15.1	13	28000	21000	1000
	EC4X29B	80G1UH090BE16	15.1	13	28000	21000	1000
	EC4X29B	80G2UH090BV16	15.1	13	28000	21000	1000
	EC4X29B	95G1UH070BE12	15.1	12.5	28000	21000	995
	EC4X29B	95G2UH045BV12	15.1	13	28000	21000	980
	EC4X29B	95G2UH070BE12	15.1	12.5	28000	21000	995
	EC4X29B	95G2UH070BV12	15.1	13	28000	21000	960
	EC4X30C	95G2UH090CE16	15.1	13	28000	21000	1040
	EC4X36A	80G1UH045AE12	15.1	13	28000	21000	1000
	EC4X36A	80G2UH070AV12	15.1	13	28000	21000	1000
	EC4X36B	80G1UH070BE12	15.1	13	28000	21000	1000
	EC4X36B	80G1UH090BE16	15.1	13	28000	21000	1000
	EC4X36B	95G2UH045BV12	15.1	13	28000	21000	980
	EC4X36B	A80US2V090B16L	15.1	13	28000	21000	1000
	EC4X36C	95G1UH090CE16	15.1	13	28000	21000	1000
	EC4X48C	95G1UH090CE16	15.1	13	28000	21000	1000
	ED1P30/36A+H4TXV01	80G1DF045AE12	15	12.5	28000	21000	1000
	ED1P30/36B+H4TXV01	80G1DF070BE12	15	12.5	28000	21000	985
	ED1P30/36B+H4TXV01	80G1DF090BE16	15	12.5	28000	21000	945
	ED1P30/36B+H4TXV01	95G1DF045BE12	15	12.5	28000	21000	985
	ED1P30/36B+H4TXV01	95G1DF070BE16	15	12.5	28000	21000	1015
	ED1P30/36B+H4TXV01	95G2DF045BE12	15	12.5	28000	21000	985
ED1P30/36B+H4TXV01	95G2DF045BV12	15	12.5	28000	21000	1000	
ED1P30/36B+H4TXV01	95G2DF070BE16	15	12.5	28000	21000	1015	
ED1P30/36B+H4TXV01	95G2DF070BV16	15	12.5	28000	21000	995	
E*1P29B	EFV12BC	14.5	12.2	28000	21000	1000	

Note:

1 Certified in accordance with Unitary Air Conditioner Certification Program, which is based on AHRI Standard 210/240

2 Required to achieve AHRI rating. If NA (Not Applicable) is in the piston column, then TXV is required

3 A blower time delay relay is required to achieve AHRI rating. This feature is standard on all Allied Air Enterprises furnace and AH products.

COOLING PERFORMANCE WITH AIR HANDLERS AND FURNACES

Outdoor Unit	Indoor Model	Furnace Model	SEER	EER	AHRI Rated Capacity BTUH	Sensible Capacity	CFM
	Evap Coil						
4AC16L30P-1	E*1P36B	EFV12BC	14.5	12.2	28000	21000	1000
	EC4X29B	EFV12BC	14.5	12.2	28000	21000	1000
	EC4X36B	EFV12BC	14.5	12.2	28000	21000	1000
	ED1P24A+H4TXV01	80G1DF045AE12	14	12.2	26000	21000	970
	ED1P24B+H4TXV01	80G1DF070BE12	14	12.2	26000	21000	970
	ED1P24B+H4TXV01	95G2DF045BV12	14	12.2	26000	21000	965
4AC16L36P-1	BCE3M36C****P		14	12.2	34000	25500	1200
	BCE3M36E****4X		14	12.2	34000	25500	1200
	E*1P36B	80G2UH090BV16	16	13	34000	25500	1200
	E*1P36B+H4TXV02	A80US2V090B16L	16	13	34000	25500	1200
	E*1P36C	95G2UH090CE16	16	13	34000	25500	1200
	E*1P36C	95G2UH090CV12	16	13	34000	25500	1200
	E*1P43B	80G2UH090BV16	16	13	34000	25500	1200
	E*1P43C	95G1UH090CE16	16	13	34000	25500	1200
	E*1P43C	95G2UH090CE16	16	13	34000	25500	1200
	E*1P43C	95G2UH090CV12	16	13	34000	25500	1200
	E*1P43C+TXV	95G1UH110CE20	16	13	34000	25500	1215
	E*1P43C+TXV	95G2UH110CE20	16	13	34000	25500	1215
	E*1P49C+TXV	95G1UH090CE16	16	13	34000	25500	1155
	E*1P49C+TXV	95G1UH110CE20	16	13	34000	25500	1215
	E*1P49C+TXV	95G2UH090CE16	16	13	34000	25500	1155
	E*1P49C+TXV	95G2UH110CE20	16	13	34000	25500	1215
	E*1P50C+TXV	95G1UH110CE20	16	13	34000	25500	1215
	E*1P50C+TXV	95G2UH110CE20	16	13	34000	25500	1215
	EC4X36B	80G2UH090BV16	16	13	34000	25500	1200
	EC4X36B	A80US2V090B16L	16	13	34000	25500	1200
	EC4X36C	95G2UH090CE16	16	13	34000	25500	1200
	EC4X36C	95G2UH090CV12	16	13	34000	25500	1200
	EC4X43B	80G2UH090BV16	16	13	34000	25500	1200
	EC4X43C	95G1UH110CE20	16	13	34000	25500	1215
	EC4X43C	95G2UH090CV12	16	13	34000	25500	1200
	EC4X43C	95G2UH110CE20	16	13	34000	25500	1215
	EC4X49C	95G1UH090CE16	16	13	34000	25500	1155
	EC4X49C	95G1UH110CE20	16	13	34000	25500	1215
	EC4X49C	95G2UH090CE16	16	13	34000	25500	1155
	EC4X49C	95G2UH110CE20	16	13	34000	25500	1215
	EC4X50C	95G1UH110CE20	16	13	34000	25500	1215
	EC4X50C	95G2UH110CE20	16	13	34000	25500	1215
	E*1P43C+TXV	95G1UH090CE16	15.5	12.5	34000	25500	1155
E*1P43C+TXV	95G2UH090CE16	15.5	12.5	34000	25500	1155	

Note:

1 Certified in accordance with Unitary Air Conditioner Certification Program, which is based on AHRI Standard 210/240

2 Required to achieve AHRI rating. If NA (Not Applicable) is in the piston column, then TXV is required

3 A blower time delay relay is required to achieve AHRI rating. This feature is standard on all Allied Air Enterprises furnace and AH products.

COOLING PERFORMANCE WITH AIR HANDLERS AND FURNACES

Outdoor Unit	Indoor Model	Furnace Model	SEER	EER	AHRI Rated Capacity BTUH	Sensible Capacity	CFM
	Evap Coil						
4AC16L36P-1	EC4X43C	95G1UH090CE16	15.5	12.5	34000	25500	1155
	EC4X43C	95G2UH090CE16	15.5	12.5	34000	25500	1155
	E*1P36A	80G2UH070AV12	15.1	13	34000	25500	1200
	E*1P36B	80G1UH090BE16	15.1	12.5	34000	25500	1180
	E*1P36B	95G2UH045BV12	15.1	13	34000	25500	1200
	E*1P36B	95G2UH070BV12	15.1	13	34000	25500	1200
	E*1P36B	EFV12BC	15.1	13	34000	25500	1200
	E*1P36C	80G1UH090CE20	15.1	13	34000	25500	1200
	E*1P36C	95G1UH090CE16	15.1	13	34000	25500	1200
	E*1P36C	95G1UH110CE20	15.1	13	34000	25500	1200
	E*1P36C	95G2UH110CE20	15.1	13	34000	25500	1200
	E*1P36C	EFV16CC	15.1	13	34000	25500	1200
	E*1P43B	80G1UH070BE12	15.1	12.2	34000	25500	1200
	E*1P43B	80G1UH090BE16	15.1	12.5	34000	25500	1180
	E*1P43B	95G1UH070BE12	15.1	12.2	34000	25500	1200
	E*1P43B	95G2UH045BV12	15.1	13	34000	25500	1200
	E*1P43B	95G2UH070BE12	15.1	13	34000	25500	1200
	E*1P43B	EFV12BC	15.1	13	34000	25500	1200
	E*1P43B+TXV	95G1UH070BE12	15.1	12.5	34000	25500	1215
	E*1P43B+TXV	95G2UH070BE12	15.1	12.5	34000	25500	1215
	E*1P43C	80G1UH090CE20	15.1	12.5	34000	25500	1200
	E*1P43C	95G1UH110CE20	15.1	13	34000	25500	1200
	E*1P43C	95G2UH110CE20	15.1	13	34000	25500	1200
	E*1P43C	EFV16CC	15.1	13	34000	25500	1200
	EC4X36A	80G2UH070AV12	15.1	13	34000	25500	1200
	EC4X36B	80G1UH090BE16	15.1	12.5	34000	25500	1180
	EC4X36B	95G2UH045BV12	15.1	13	34000	25500	1200
	EC4X36B	95G2UH070BV12	15.1	13	34000	25500	1200
	EC4X36B	EFV12BC	15.1	13	34000	25500	1200
	EC4X36C	80G1UH090CE20	15.1	13	34000	25500	1200
	EC4X36C	95G1UH090CE16	15.1	13	34000	25500	1200
	EC4X36C	95G1UH110CE20	15.1	13	34000	25500	1200
	EC4X36C	95G2UH110CE20	15.1	13	34000	25500	1200
	EC4X36C	EFV16CC	15.1	13	34000	25500	1200
	EC4X43B	80G1UH070BE12	15.1	12.2	34000	25500	1200
	EC4X43B	80G1UH090BE16	15.1	12.5	34000	25500	1180
EC4X43B	95G1UH070BE12	15.1	12.5	34000	25500	1215	
EC4X43B	95G2UH045BV12	15.1	13	34000	25500	1200	
EC4X43B	95G2UH070BE12	15.1	12.5	34000	25500	1215	
EC4X43B	EFV12BC	15.1	13	34000	25500	1200	

Note:

1 Certified in accordance with Unitary Air Conditioner Certification Program, which is based on AHRI Standard 210/240

2 Required to achieve AHRI rating. If NA (Not Applicable) is in the piston column, then TXV is required

3 A blower time delay relay is required to achieve AHRI rating. This feature is standard on all Allied Air Enterprises furnace and AH products.

COOLING PERFORMANCE WITH AIR HANDLERS AND FURNACES

Outdoor Unit	Indoor Model	Furnace Model	SEER	EER	AHRI Rated Capacity BTUH	Sensible Capacity	CFM
	Evap Coil						
4AC16L36P-1	EC4X43C	80G1UH090CE20	15.1	12.5	34000	25500	1200
	EC4X43C	EFV16CC	15.1	13	34000	25500	1200
	E*1P36B+TXV	95G1UH070BE12	15	12.5	34000	25500	1215
	E*1P36B+TXV	95G2UH070BE12	15	12.5	34000	25500	1215
	E*1P43B+TXV	95G1UH045BE12	15	12.5	34000	25500	1215
	E*1P43B+TXV	95G2UH045BE12	15	12.5	34000	25500	1215
	EC4X36B	95G1UH070BE12	15	12.5	34000	25500	1215
	EC4X36B	95G2UH070BE12	15	12.5	34000	25500	1215
	EC4X43B	95G1UH045BE12	15	12.5	34000	25500	1215
	EC4X43B	95G2UH045BE12	15	12.5	34000	25500	1215
	ED1P30/36B+H4TXV01	80G1DF070BE12	15	12.5	33000	25500	1110
	ED1P30/36B+H4TXV01	80G1DF090BE16	15	12.5	33000	25500	1165
	ED1P30/36B+H4TXV01	95G1DF070BE16	15	12.5	33000	25500	1155
	ED1P30/36B+H4TXV01	95G2DF070BE16	15	12.5	33000	25500	1155
	ED1P48B+H4TXV02	80G1DF070BE12	15	12.5	34000	25500	1220
	ED1P48B+H4TXV02	80G1DF090BE16	15	12.5	34000	25500	1165
	ED1P48B+H4TXV02	95G1DF045BE12	15	12.5	34000	25500	1150
	ED1P48B+H4TXV02	95G1DF070BE16	15	12.5	34000	25500	1155
	ED1P48B+H4TXV02	95G2DF045BE12	15	12.5	34000	25500	1150
	ED1P48B+H4TXV02	95G2DF045BV12	15	12.5	34000	25500	1210
	ED1P48B+H4TXV02	95G2DF070BE16	15	12.5	34000	25500	1155
	ED1P48B+H4TXV02	95G2DF070BV16	15	12.5	34000	25500	1230
	ED1P48C+H4TXV02	95G1DF090CE16	15	12.5	34000	25500	1185
	ED1P48C+H4TXV02	95G1DF110CE20	15	12.5	34000	25500	1190
	ED1P48C+H4TXV02	95G2DF090CE16	15	12.5	34000	25500	1185
	ED1P48C+H4TXV02	95G2DF090CV20	15	12.5	34000	25500	1270
	ED1P48C+H4TXV02	95G2DF110CE20	15	12.5	34000	25500	1190
	ED1P48C+H4TXV02	95G2DF110CV20	15	12.5	34000	25500	1275
	E*1P36A	80G1UH045AE12	14.5	12.2	34000	25500	1200
	E*1P36B	95G1UH045BE12	14.5	12.2	34000	25500	1200
	E*1P36B	95G1UH070BE12	14.5	12.2	34000	25500	1200
	E*1P36B	95G2UH045BE12	14.5	12.2	34000	25500	1190
	E*1P36B	95G2UH070BE12	14.5	12.2	34000	25500	1200
	E*1P43B	95G1UH045BE12	14.5	12.2	34000	25500	1200
	E*1P43B	95G2UH045BE12	14.5	12.2	34000	25500	1190
	E*1P43B	95G2UH070BV12	14.5	12.5	34000	25500	1200
	EC4X36A	80G1UH045AE12	14.5	12.2	34000	25500	1200
	EC4X36B	95G1UH045BE12	14.5	12.2	34000	25500	1200
	EC4X36B	95G2UH045BE12	14.5	12.2	34000	25500	1190
	EC4X43B	95G2UH070BV12	14.5	12.5	34000	25500	1200

Note:

1 Certified in accordance with Unitary Air Conditioner Certification Program, which is based on AHRI Standard 210/240

2 Required to achieve AHRI rating. If NA (Not Applicable) is in the piston column, then TXV is required

3 A blower time delay relay is required to achieve AHRI rating. This feature is standard on all Allied Air Enterprises furnace and AH products.

COOLING PERFORMANCE WITH AIR HANDLERS AND FURNACES

Outdoor Unit	Indoor Model	Furnace Model	SEER	EER	AHRI Rated Capacity BTUH	Sensible Capacity	CFM
	Evap Coil						
4AC16L36P-1	ED1P30/36A+H4TXV01	80G1DF045AE12	14	12.2	33000	25500	1215
	ED1P30/36B+H4TXV01	95G2DF045BV12	14	12.2	33000	25500	1210
	ED1P30/36B+H4TXV01	95G2DF070BV16	14	12.2	33000	25500	1230
	ED1P48C+H4TXV02	80G1DF110CE20	14	12.2	33000	25500	1200
4AC16L41P-1	BCE3M42E****4X		16	13	38000	28000	1380
	BCE3M42V****4X		16	13	38000	28000	1380
	BCE3M48V****4X		16	13	38000	28000	1380
	BCE3M42C****4X		14	12.2	38000	28000	1380
	BCE3M42C****P+TXV		14	12.2	38000	28000	1380
	E(C,H,U)1P49C+TXV	95G1UH090CE16	16	13	38000	28000	1350
	E(C,H,U)1P49C+TXV	95G2UH090CE16	16	13	38000	28000	1350
	E(C,H,U)1P62C	95G2UH090CE16	16	13	38000	28000	1350
	E(C,H,U)1P62C+TXV	80G1UH090CE20	16	13	38000	28000	1400
	E(C,H,U)1P62C+TXV	80G1UH110CE20	16	13	38000	28000	1400
	E(C,H,U)1P62C+TXV	95G1UH090CE16	16	13	38000	28000	1350
	E(C,H,U)1P62C+TXV	95G2UH090CE16	16	13	38000	28000	1350
	E*1P49C+H4TXV02	80G1UH090CE20	16	13	38000	28000	1400
	E*1P49C+H4TXV02	80G1UH110CE20	16	13	38000	28000	1400
	E*1P49C+H4TXV02	95G1UH090CE16	16	13	38000	28000	1350
	E*1P49C+H4TXV02	95G2UH090CE16	16	13	38000	28000	1350
	E*1P62C+H4TXV02	80G1UH090CE20	16	13	38000	28000	1400
	E*1P62C+H4TXV02	80G1UH110CE20	16	13	38000	28000	1400
	E*1P62C+H4TXV02	95G1UH090CE16	16	13	38000	28000	1350
	E*1P62C+H4TXV02	95G2UH090CE16	16	13	38000	28000	1350
	EC4X49C	80G1UH090CE20	16	13	38000	28000	1400
	EC4X49C	80G1UH110CE20	16	13	38000	28000	1400
	EC4X49C	95G1UH090CE16	16	13	38000	28000	1350
	EC4X49C	95G2UH090CE16	16	13	38000	28000	1350
	EC4X62C	80G1UH090CE20	16	13	38000	28000	1400
	EC4X62C	80G1UH110CE20	16	13	38000	28000	1400
	EC4X62C	95G1UH090CE16	16	13	38000	28000	1350
	EC4X62C	95G2UH090CE16	16	13	38000	28000	1350
	E(C,H,U)1P49C+TXV	80G1UH090CE20	15.1	12.5	38000	28000	1400
	E(C,H,U)1P49C+TXV	80G1UH110CE20	15.1	12.5	38000	28000	1400
	E(C,H,U)1P49C+TXV	80G2UH110CV20	15.1	12.5	38000	28000	1400
	E(C,H,U)1P49C+TXV	95G1UH110CE20	15.1	13	38000	28000	1400
	E(C,H,U)1P49C+TXV	95G2UH090CV20	15.1	13	38000	28000	1400
	E(C,H,U)1P49C+TXV	95G2UH110CE20	15.1	13	38000	28000	1400
	E(C,H,U)1P49C+TXV	95G2UH110CV20	15.1	13	38000	28000	1400
	E(C,H,U)1P49C+TXV+TDR	EFV16CC	15.1	12.5	38000	28000	1400

Note:

1 Certified in accordance with Unitary Air Conditioner Certification Program, which is based on AHRI Standard 210/240

2 Required to achieve AHRI rating. If NA (Not Applicable) is in the piston column, then TXV is required

3 A blower time delay relay is required to achieve AHRI rating. This feature is standard on all Allied Air Enterprises furnace and AH products.

COOLING PERFORMANCE WITH AIR HANDLERS AND FURNACES

Outdoor Unit	Indoor Model	Furnace Model	SEER	EER	AHRI Rated Capacity BTUH	Sensible Capacity	CFM
	Evap Coil						
4AC16L41P-1	E(C,H,U)1P62C+TXV	80G2UH110CV20	15.1	13	38000	28000	1400
	E(C,H,U)1P62C+TXV	95G1UH110CE20	15.1	13	38000	28000	1400
	E(C,H,U)1P62C+TXV	95G2UH090CV20	15.1	13	38000	28000	1400
	E(C,H,U)1P62C+TXV	95G2UH110CE20	15.1	13	38000	28000	1400
	E(C,H,U)1P62C+TXV	95G2UH110CV20	15.1	13	38000	28000	1400
	E(C,H,U)1P62C+TXV+TDR	EFV16CC	15.1	12.5	38000	28000	1400
	E*1P49C+H4TXV02	80G2UH110CV20	15.1	13	38000	28000	1400
	E*1P49C+H4TXV02	95G1UH110CE20	15.1	12.5	38000	28000	1400
	E*1P49C+H4TXV02	95G2UH090CV20	15.1	12.5	38000	28000	1400
	E*1P49C+H4TXV02	95G2UH110CE20	15.1	12.5	38000	28000	1400
	E*1P49C+H4TXV02	95G2UH110CV20	15.1	12.5	38000	28000	1400
	E*1P49C+H4TXV02	A80US2V110C20L	15.1	13	38000	28000	1400
	E*1P49C+H4TXV02	EFV16CC	15.1	12.5	38000	28000	1400
	E*1P62C+H4TXV02	80G2UH110CV20	15.1	13	38000	28000	1400
	E*1P62C+H4TXV02	95G1UH110CE20	15.1	13	38000	28000	1400
	E*1P62C+H4TXV02	95G2UH090CV20	15.1	13	38000	28000	1400
	E*1P62C+H4TXV02	95G2UH110CE20	15.1	13	38000	28000	1400
	E*1P62C+H4TXV02	95G2UH110CV20	15.1	13	38000	28000	1400
	E*1P62C+H4TXV02	EFV16CC	15.1	12.5	38000	28000	1400
	EC4X49C	80G2UH110CV20	15.1	13	38000	28000	1400
	EC4X49C	95G1UH110CE20	15.1	12.5	38000	28000	1400
	EC4X49C	95G2UH090CV20	15.1	12.5	38000	28000	1400
	EC4X49C	95G2UH110CE20	15.1	12.5	38000	28000	1400
	EC4X49C	95G2UH110CV20	15.1	12.5	38000	28000	1400
	EC4X49C	A80US2V110C20L	15.1	13	38000	28000	1400
	EC4X49C	EFV16CC	15.1	12.5	38000	28000	1400
	EC4X62C	80G2UH110CV20	15.1	13	38000	28000	1400
	EC4X62C	95G1UH110CE20	15.1	13	38000	28000	1400
	EC4X62C	95G2UH090CV20	15.1	13	38000	28000	1400
	EC4X62C	95G2UH110CE20	15.1	13	38000	28000	1400
	EC4X62C	95G2UH110CV20	15.1	13	38000	28000	1400
	EC4X62C	EFV16CC	15.1	12.5	38000	28000	1400
	ED1P50/60C+H4TXV02	80G1DF110CE20	15	12.5	38000	28000	1425
	ED1P50/60C+H4TXV02	95G1DF090CE16	15	12.5	38000	28000	1370
	ED1P50/60C+H4TXV02	95G1DF110CE20	15	12.5	38000	28000	1420
	ED1P50/60C+H4TXV02	95G2DF090CE16	15	12.5	38000	28000	1370
	ED1P50/60C+H4TXV02	95G2DF090CV20	15	12.5	36000	28000	1270
	ED1P50/60C+H4TXV02	95G2DF110CE20	15	12.5	38000	28000	1420
	ED1P50/60C+H4TXV02	95G2DF110CV20	15	12.5	38000	28000	1425

Note:

1 Certified in accordance with Unitary Air Conditioner Certification Program, which is based on AHRI Standard 210/240

2 Required to achieve AHRI rating. If NA (Not Applicable) is in the piston column, then TXV is required

3 A blower time delay relay is required to achieve AHRI rating. This feature is standard on all Allied Air Enterprises furnace and AH products.

COOLING PERFORMANCE WITH AIR HANDLERS AND FURNACES

Outdoor Unit	Indoor Model	Furnace Model	SEER	EER	AHRI Rated Capacity BTUH	Sensible Capacity	CFM
	Evap Coil						
4AC16L42P-1	BCE3M42E****4X		14.5	12.2	40000	30000	1400
	BCE3M42C****P+H4TXV02		14	12.2	40000	30000	1400
	BCE3M48E****4X		14	12.2	40000	30000	1400
	E*1P62C+TXV	95G1UH090CE16	16	13	41000	30000	1345
	E*1P62C+TXV	95G1UH110CE20	16	13	41000	30000	1455
	E*1P62C+TXV	95G2UH090CE16	16	13	41000	30000	1345
	E*1P62C+TXV	95G2UH110CE20	16	13	41000	30000	1455
	E*1P49C+TXV	95G1UH090CE16	15.5	12.5	41000	30000	1355
	E*1P49C+TXV	95G1UH110CE20	15.5	12.5	41000	30000	1460
	E*1P49C+TXV	95G2UH090CE16	15.5	12.5	41000	30000	1355
	E*1P49C+TXV	95G2UH110CE20	15.5	12.5	41000	30000	1460
	E*1P49C+H4TXV02	80G1UH090CE20	15.1	12.5	41000	30000	1400
	E*1P49C+H4TXV02	80G1UH110CE20	15.1	12.5	41000	30000	1400
	E*1P49C+H4TXV02	80G2UH110CV20	15.1	12.5	41000	30000	1400
	E*1P49C+H4TXV02	95G2UH090CV20	15.1	12.5	41000	30000	1400
	E*1P49C+H4TXV02	95G2UH110CV20	15.1	12.5	41000	30000	1400
	E*1P49C+H4TXV02	A80US2V110C20L	15.1	12.5	40000	30000	1400
	E*1P62C+H4TXV02	80G1UH090CE20	15.1	12.5	41000	30000	1400
	E*1P62C+H4TXV02	80G1UH110CE20	15.1	12.5	41000	30000	1400
	E*1P62C+H4TXV02	80G2UH110CV20	15.1	12.5	41000	30000	1400
	E*1P62C+H4TXV02	95G2UH090CV20	15.1	12.5	41000	30000	1400
	E*1P62C+H4TXV02	95G2UH110CE20	15.1	12.5	41000	30000	1400
	E*1P62C+H4TXV02	95G2UH110CV20	15.1	12.5	41000	30000	1400
	EC4X49C	80G1UH090CE20	15.1	12.5	41000	30000	1400
	EC4X49C	80G1UH110CE20	15.1	12.5	41000	30000	1400
	EC4X49C	80G2UH110CV20	15.1	12.5	41000	30000	1400
	EC4X49C	95G2UH090CV20	15.1	12.5	41000	30000	1400
	EC4X49C	95G2UH110CV20	15.1	12.5	41000	30000	1400
	EC4X49C	A80US2V110C20L	15.1	12.5	40000	30000	1400
	EC4X62C	80G1UH090CE20	15.1	12.5	41000	30000	1400
	EC4X62C	80G1UH110CE20	15.1	12.5	41000	30000	1400
	EC4X62C	80G2UH110CV20	15.1	12.5	41000	30000	1400
	EC4X62C	95G2UH090CV20	15.1	12.5	41000	30000	1400
	EC4X62C	95G2UH110CV20	15.1	12.5	41000	30000	1400
	EC4X62C	95G2UH110CE20	15.1	12.5	41000	30000	1400
	EC4X62C	95G2UH110CV20	15.1	12.5	41000	30000	1400
	ED1P48C+H4TXV02	80G1DF110CE20	15	12.5	40000	30000	1385
	ED1P48C+H4TXV02	95G1DF090CE16	15	12.5	40000	30000	1340
	ED1P48C+H4TXV02	95G1DF110CE20	15	12.5	40000	30000	1415
	ED1P48C+H4TXV02	95G2DF090CE16	15	12.5	40000	30000	1340
ED1P48C+H4TXV02	95G2DF110CE20	15	12.5	40000	30000	1415	

Note:

1 Certified in accordance with Unitary Air Conditioner Certification Program, which is based on AHRI Standard 210/240

2 Required to achieve AHRI rating. If NA (Not Applicable) is in the piston column, then TXV is required

3 A blower time delay relay is required to achieve AHRI rating. This feature is standard on all Allied Air Enterprises furnace and AH products.

COOLING PERFORMANCE WITH AIR HANDLERS AND FURNACES

Outdoor Unit	Indoor Model	Furnace Model	SEER	EER	AHRI Rated Capacity BTUH	Sensible Capacity	CFM	
	Evap Coil							
4AC16L42P-1	ED1P50/60C+H4TXV02	80G1DF110CE20	15	12.5	41000	30000	1425	
	ED1P50/60C+H4TXV02	95G1DF090CE16	15	12.5	41000	30000	1365	
	ED1P50/60C+H4TXV02	95G1DF110CE20	15	12.5	41000	30000	1450	
	ED1P50/60C+H4TXV02	95G2DF090CE16	15	12.5	41000	30000	1365	
	ED1P50/60C+H4TXV02	95G2DF090CV20	15	12.5	41000	30000	1450	
	ED1P50/60C+H4TXV02	95G2DF110CE20	15	12.5	41000	30000	1450	
	ED1P50/60C+H4TXV02	95G2DF110CV20	15	12.5	41000	30000	1440	
	E*1P49C+H4TXV02	95G1UH110CE20	14.5	12.2	41000	30000	1400	
	E*1P49C+H4TXV02	95G2UH110CE20	14.5	12.2	41000	30000	1400	
	E*1P62C+H4TXV02	95G1UH110CE20	14.5	12.2	41000	30000	1400	
	E*1P62C+H4TXV02	EFV16CC	14.5	12.2	41000	30000	1400	
	EC4X49C	95G1UH110CE20	14.5	12.2	41000	30000	1400	
	EC4X49C	95G2UH110CE20	14.5	12.2	41000	30000	1400	
	EC4X62C	95G1UH110CE20	14.5	12.2	41000	30000	1400	
	EC4X62C	EFV16CC	14.5	12.2	41000	30000	1400	
	E*1P49C+H4TXV02	95G1UH090CE16	14	12.2	41000	30000	1355	
	E*1P49C+H4TXV02	95G2UH090CE16	14	12.2	41000	30000	1400	
	E*1P49C+H4TXV02	EFV16CC	14	12.2	41000	30000	1400	
	E*1P62C+H4TXV02	95G1UH090CE16	14	12.2	41000	30000	1355	
	E*1P62C+H4TXV02	95G2UH090CE16	14	12.2	41000	30000	1400	
	EC4X49C	95G1UH090CE16	14	12.2	41000	30000	1355	
	EC4X49C	95G2UH090CE16	14	12.2	41000	30000	1400	
	EC4X49C	EFV16CC	14	12.2	41000	30000	1400	
	EC4X62C	95G1UH090CE16	14	12.2	41000	30000	1355	
	EC4X62C	95G2UH090CE16	14	12.2	41000	30000	1400	
	ED1P48C+H4TXV02	95G2DF090CV20	14	12.2	40000	30000	1450	
	4AC16L47P-1	BCE3M48E***4X		16	13	45500	35000	1600
		BCE3M48V***4X		16	13	45500	35000	1600
BCE3M48C***P+TXV			14	12	45500	35000	1600	
E(C,H,U)1P49C+TXV		80G1UH090CE20	16	13	46000	35000	1700	
E(C,H,U)1P49C+TXV		80G2UH110CV20	16	13	46000	35000	1600	
E(C,H,U)1P62C+TXV		80G1UH090CE20	16	13	46000	35000	1545	
E(C,H,U)1P62C+TXV		80G1UH110CE20	16	13	46000	35000	1535	
E(C,H,U)1P62C+TXV		80G2UH110CV20	16	13	46000	35000	1600	
EC4X49C		80G1UH090CE20	16	13	46000	35000	1700	
EC4X49C		80G2UH110CV20	16	13	46000	35000	1600	
EC4X62C		80G1UH090CE20	16	13	46000	35000	1545	
EC4X62C		80G1UH110CE20	16	13	46000	35000	1535	
EC4X62C		80G2UH110CV20	16	13	46000	35000	1600	
E(C,H,U)1P62C+TXV+TDR		EFV16CC	15.5	12.5	46000	35000	1600	

Note:

1 Certified in accordance with Unitary Air Conditioner Certification Program, which is based on AHRI Standard 210/240

2 Required to achieve AHRI rating. If NA (Not Applicable) is in the piston column, then TXV is required

3 A blower time delay relay is required to achieve AHRI rating. This feature is standard on all Allied Air Enterprises furnace and AH products.

COOLING PERFORMANCE WITH AIR HANDLERS AND FURNACES

Outdoor Unit	Indoor Model	Furnace Model	SEER	EER	AHRI Rated Capacity BTUH	Sensible Capacity	CFM
	Evap Coil						
4AC16L47P-1	EC4X62C	EFV16CC	15.5	12.5	46000	35000	1600
	E(C,H,U)1P49C+TXV	80G1UH110CE20	15.1	12.5	46000	35000	1700
	E(C,H,U)1P49C+TXV	95G1UH110CE20	15.1	12.5	46000	35000	1500
	E(C,H,U)1P49C+TXV	95G2UH090CV20	15.1	12.5	46000	35000	1600
	E(C,H,U)1P49C+TXV	95G2UH110CE20	15.1	13	46000	35000	1500
	E(C,H,U)1P62C+TXV	95G1UH110CE20	15.1	13	46000	35000	1500
	E(C,H,U)1P62C+TXV	95G2UH090CV20	15.1	12.5	46000	35000	1600
	E(C,H,U)1P62C+TXV	95G2UH110CE20	15.1	13	46000	35000	1500
	E(C,H,U)1P62C+TXV	95G2UH110CV20	15.1	12.5	46000	35000	1600
	E(C,H,U)1P62D+TXV	80G1UH135DE20	15.1	13	46000	35000	1600
	E(C,H,U)1P62D+TXV	95G1UH135DE20	15.1	12.5	46000	35000	1600
	E(C,H,U)1P62D+TXV	95G2UH135DE20	15.1	12.5	46000	35000	1600
	E(C,H,U)1P62D+TXV	95G2UH135DV20	15.1	12.5	46000	35000	1600
	EC4X49C	80G1UH110CE20	15.1	12.5	46000	35000	1700
	EC4X49C	95G1UH110CE20	15.1	12.5	46000	35000	1500
	EC4X49C	95G2UH090CV20	15.1	12.5	46000	35000	1600
	EC4X49C	95G2UH110CE20	15.1	13	46000	35000	1500
	EC4X62C	95G1UH110CE20	15.1	13	46000	35000	1500
	EC4X62C	95G2UH090CV20	15.1	12.5	46000	35000	1600
	EC4X62C	95G2UH110CE20	15.1	13	46000	35000	1500
	EC4X62C	95G2UH110CV20	15.1	12.5	46000	35000	1600
	EC4X62D	80G1UH135DE20	15.1	13	46000	35000	1600
	EC4X62D	95G1UH135DE20	15.1	12.5	46000	35000	1600
	EC4X62D	95G2UH135DE20	15.1	12.5	46000	35000	1600
	EC4X62D	95G2UH135DV20	15.1	12.5	46000	35000	1600
	E(C,H,U)1P49C+TXV	95G2UH110CV20	15	12.5	46000	35000	1600
	EC4X49C	95G2UH110CV20	15	12.5	46000	35000	1600
	ED1P50/60C+H4TXV02	80G1DF110CE20	15	12.5	45000	35000	1595
	ED1P50/60C+H4TXV02	95G1DF090CE16	14	12.2	44500	35000	1570
	ED1P50/60C+H4TXV02	95G1DF110CE20	14	12.2	44500	35000	1565
	ED1P50/60C+H4TXV02	95G2DF090CE16	14	12.2	44500	35000	1570
	ED1P50/60C+H4TXV02	95G2DF110CE20	14	12.2	44500	35000	1565
	4AC16L48P-1	BCE3M48E***4X		15.1	12.5	46500	34500
BCE3M48V***4X			14.5	11.7	47000	34500	1600
BCE3M48C***P+H4TXV02			14	12	46500	34500	1600
E*1P62C+H4TXV02		80G1UH090CE20	15.1	12.5	46500	34500	1545
E*1P62C+H4TXV02		80G1UH110CE20	15.1	13	46500	34500	1500
EC4X62C		80G1UH090CE20	15.1	12.5	46500	34500	1545
EC4X62C		80G1UH110CE20	15.1	13	46500	34500	1500
E*1P60D+H4TXV02	80G1UH135DE20	14.5	12	46000	34500	1600	

Note:

1 Certified in accordance with Unitary Air Conditioner Certification Program, which is based on AHRI Standard 210/240

2 Required to achieve AHRI rating. If NA (Not Applicable) is in the piston column, then TXV is required

3 A blower time delay relay is required to achieve AHRI rating. This feature is standard on all Allied Air Enterprises furnace and AH products.

COOLING PERFORMANCE WITH AIR HANDLERS AND FURNACES

Outdoor Unit	Indoor Model	Furnace Model	SEER	EER	AHRI Rated Capacity BTUH	Sensible Capacity	CFM
	Evap Coil						
4AC16L48P-1	E*1P60D+H4TXV02	95G2UH135DV20	14.5	12	46000	34500	1600
	E*1P62C+H4TXV02	80G2UH110CV20	14.5	12	46500	34500	1600
	E*1P62C+H4TXV02	95G2UH090CE16	14.5	11.7	46500	34500	1600
	E*1P62C+TXV	95G2UH090CE16	14.5	12.5	46500	34500	1560
	E*1P62D+H4TXV02	80G1UH135DE20	14.5	12	46500	34500	1600
	E*1P62D+H4TXV02	95G2UH135DV20	14.5	12	46500	34500	1600
	EC4X62C	80G2UH110CV20	14.5	12	46500	34500	1600
	EC4X62C	95G2UH090CE16	14.5	11.7	46500	34500	1600
	EC4X62D	80G1UH135DE20	14.5	12	46500	34500	1600
	EC4X62D	95G2UH135DV20	14.5	12	46500	34500	1600
	ED1P48C+H4TXV02	80G1DF110CE20	14	11.7	46500	34500	1545
	ED1P48C+H4TXV02	95G1DF110CE20	14	11.7	46500	34500	1510
	ED1P48C+H4TXV02	95G2DF110CE20	14	11.7	46500	34500	1510
	ED1P50/60C+H4TXV02	80G1DF110CE20	14	11.7	47500	34500	1595
	ED1P50/60C+H4TXV02	95G1DF110CE20	14	11.7	47000	34500	1565
	ED1P50/60C+H4TXV02	95G2DF090CV20	14	11.7	47000	34500	1600
	ED1P50/60C+H4TXV02	95G2DF110CE20	14	11.7	47000	34500	1565
	ED1P50/60C+H4TXV02	95G2DF110CV20	14	11.7	47000	34500	1585
	4AC16L59P-1	BCE3M60E***4X		14.5	12	56500	41500
BCE3M60V***4X			14.5	12	56000	41500	1780
BCE3M48C***P+H4TXV03			14	12	57000	41500	1800
BCE3M60C***P+H4TXV03			14	12	56500	41500	1800
E*1P62C+A4TXV02+TDR		95G1UH110CE20	15.4	12.5	57000	41500	1800
E*1P62C+H4TXV02+TDR		A95UH1E110C20	15.4	12.5	57000	41500	1800
EC4X62C		A95UH1E110C20	15.4	12.5	57000	41500	1800
E*1P62D+H4TXV03		80G1UH135DE20	15.1	12.5	58000	41500	1800
EC4X62D		80G1UH135DE20	15.1	12.5	58000	41500	1800
E*1P62C+H4TXV03		80G1UH090CE20	14.5	12.5	58000	41500	1770
E*1P62C+H4TXV03		80G1UH110CE20	14.5	12.5	58000	41500	1800
E*1P62C+H4TXV03		95G1UH110CE20	14.5	12.5	58000	41500	1770
E*1P62C+H4TXV03		A80US2V0110C20	14.5	12	57000	41500	1800
E*1P62C+H4TXV03		A80US2V090C20	14.5	12	57000	41500	1800
E*1P62D+H4TXV03		95G2UH135DV20	14.5	12.5	58000	41500	1800
EC4X62C		80G1UH090CE20	14.5	12.5	58000	41500	1770
EC4X62C		80G1UH110CE20	14.5	12.5	58000	41500	1800
EC4X62C		95G1UH110CE20	14.5	12.5	58000	41500	1770
EC4X62C		A80US2V0110C20	14.5	12	57000	41500	1800
EC4X62C		A80US2V090C20	14.5	12	57000	41500	1800
EC4X62D		95G2UH135DV20	14.5	12.5	58000	41500	1800
ED1P50/60C+H4TXV02		80G1DF110CE20	14	12.2	56000	41500	1800
ED1P50/60C+H4TXV02		95G1DF110CE20	14	11.7	55500	41500	1700
ED1P50/60C+H4TXV02		95G2DF110CE20	14	11.7	55500	41500	1700

COOLING PERFORMANCE WITH AIR HANDLERS AND FURNACES

Outdoor Unit	Indoor Model	Furnace Model	SEER	EER	AHRI Rated Capacity BTUH	Sensible Capacity	CFM
	Evap Coil						
4AC16L60P-1	BCE3M60C****P+H4TXV03		14	12	58000	42000	1800
	BCE3M60V****4X		14	12	58000	42000	1780
	ED1P50/60C+H4TXV03	80G1DF110CE20	14	11.7	57000	42000	1800
	ED1P50/60C+H4TXV03	95G1DF110CE20	14	11.7	57000	42000	1800
	ED1P50/60C+H4TXV03	95G2DF110CE20	14	11.7	57000	42000	1800
4AC16LR18P-1	BCE3M24E****4X		15.1	13	18000	13000	650
	BCE3M18V****4X		14.5	12.2	18000	13000	600
	BCE3M24V****4X		14.5	12.2	18000	13000	650
	BCE3M18C****P		14	12.2	18000	13000	650
	E*1P19A	80G2UH070AV12	16	13	18000	13000	650
	E*1P23A	80G2UH070AV12	16	13	18000	13000	650
	E*1P23B	80G2UH090BV16	16	13	18000	13000	620
	E*1P23B	95G2UH045BV12	16	13	18000	13000	650
	E*1P23B	95G2UH070BV12	16	13	18000	13000	650
	E*1P23B	EFV08BC	16	13	18000	13000	650
	E*1P23B+TXV	95G1UH045BE12	16	13	18000	13000	635
	E*1P23B+TXV	95G2UH045BE12	16	13	18000	13000	635
	E*1P24A	80G2UH070AV12	16	13	18000	13000	650
	E*1P24B	80G2UH090BV16	16	13	18000	13000	620
	E*1P24B	95G2UH070BV12	16	13	18000	13000	650
	E*1P29A	80G2UH070AV12	16	13	18000	13000	650
	E*1P29B	80G2UH090BV16	16	13	18000	13000	620
	E*1P29B	95G2UH045BV12	16	13	18000	13000	650
	E*1P29B	95G2UH070BV12	16	13	18000	13000	650
	E*1P29B+TXV	95G1UH045BE12	16	13	18000	13000	635
	E*1P29B+TXV	95G2UH045BE12	16	13	18000	13000	635
	E*1P30A	80G1UH045AE12	16	13	18000	13000	650
	E*1P30A	80G2UH070AV12	16	13	18000	13000	650
	E*1P30B	80G2UH090BV16	16	13	18000	13000	620
	E*1P30B	95G2UH045BV12	16	13	18000	13000	650
	E*1P30B	95G2UH070BV12	16	13	18000	13000	650
	E*1P30C	95G2UH090CV12	16	13	18000	13000	650
	E*1P36A	80G2UH070AV12	16	13	18000	13000	650
	E*1P36B	80G2UH090BV16	16	13	18000	13000	620
	E*1P36B	95G2UH045BV12	16	13	18000	13000	650
	E*1P36B	95G2UH070BV12	16	13	18000	13000	650
	E*1P36C	95G2UH090CV12	16	13	18000	13000	650
	EC4X23A	80G2UH070AV12	16	13	18000	13000	650
EC4X23B	80G2UH090BV16	16	13	18000	13000	620	
EC4X23B	95G1UH045BE12	16	13	18000	13000	635	

Note:

1 Certified in accordance with Unitary Air Conditioner Certification Program, which is based on AHRI Standard 210/240

2 Required to achieve AHRI rating. If NA (Not Applicable) is in the piston column, then TXV is required

3 A blower time delay relay is required to achieve AHRI rating. This feature is standard on all Allied Air Enterprises furnace and AH products.

COOLING PERFORMANCE WITH AIR HANDLERS AND FURNACES

Outdoor Unit	Indoor Model	Furnace Model	SEER	EER	AHRI Rated Capacity BTUH	Sensible Capacity	CFM
	Evap Coil						
4ACT16LE18P-1	EC4X23B	95G2UH045BE12	16	13	18000	13000	635
	EC4X23B	95G2UH045BV12	16	13	18000	13000	650
	EC4X23B	95G2UH070BV12	16	13	18000	13000	650
	EC4X23B	EFV08BC	16	13	18000	13000	650
	EC4X24A	80G2UH070AV12	16	13	18000	13000	650
	EC4X24B	80G2UH090BV16	16	13	18000	13000	620
	EC4X24B	95G2UH070BV12	16	13	18000	13000	650
	EC4X29A	80G2UH070AV12	16	13	18000	13000	650
	EC4X29B	80G2UH090BV16	16	13	18000	13000	620
	EC4X29B	95G1UH045BE12	16	13	18000	13000	635
	EC4X29B	95G2UH045BE12	16	13	18000	13000	635
	EC4X29B	95G2UH045BV12	16	13	18000	13000	650
	EC4X29B	95G2UH070BV12	16	13	18000	13000	650
	EC4X30A	80G1UH045AE12	16	13	18000	13000	650
	EC4X30A	80G2UH070AV12	16	13	18000	13000	650
	EC4X30B	80G2UH090BV16	16	13	18000	13000	620
	EC4X30B	95G2UH045BV12	16	13	18000	13000	650
	EC4X30B	95G2UH070BV12	16	13	18000	13000	650
	EC4X30C	95G2UH090CV12	16	13	18000	13000	650
	EC4X36A	80G2UH070AV12	16	13	18000	13000	650
	EC4X36B	80G2UH090BV16	16	13	18000	13000	620
	EC4X36B	95G2UH045BV12	16	13	18000	13000	650
	EC4X36B	95G2UH070BV12	16	13	18000	13000	650
	EC4X36C	95G2UH090CV12	16	13	18000	13000	650
	E*1P19A	80G1UH045AE12	15.1	13	18000	13000	650
	E*1P23B	80G1UH070BE12	15.1	13	18000	13000	650
	E*1P23B	95G1UH045BE12	15.1	13	18000	13000	650
	E*1P23B	95G1UH070BE12	15.1	13	18000	13000	650
	E*1P23B	95G2UH045BE12	15.1	13	18000	13000	620
	E*1P23B	95G2UH070BE12	15.1	13	18000	13000	650
	E*1P24A	80G1UH045AE12	15.1	13	18000	13000	650
	E*1P24B	80G1UH070BE12	15.1	13	18000	13000	620
	E*1P24B	95G1UH045BE12	15.1	13	18000	13000	620
	E*1P24B	95G2UH045BE12	15.1	13	18000	13000	620
E*1P24B	95G2UH045BV12	15.1	13	18000	13000	650	
E*1P24B	EFV08BC	15.1	13	18000	13000	650	
E*1P24B+TXV	95G1UH045BE12	15.1	12.5	18000	13000	635	
E*1P24B+TXV	95G2UH045BE12	15.1	12.5	18000	13000	635	
E*1P29A	80G1UH045AE12	15.1	13	18000	13000	650	
E*1P29B	80G1UH070BE12	15.1	13	18000	13000	620	

Note:

1 Certified in accordance with Unitary Air Conditioner Certification Program, which is based on AHRI Standard 210/240

2 Required to achieve AHRI rating. If NA (Not Applicable) is in the piston column, then TXV is required

3 A blower time delay relay is required to achieve AHRI rating. This feature is standard on all Allied Air Enterprises furnace and AH products.

COOLING PERFORMANCE WITH AIR HANDLERS AND FURNACES

Outdoor Unit	Indoor Model	Furnace Model	SEER	EER	AHRI Rated Capacity BTUH	Sensible Capacity	CFM
	Evap Coil						
4AC16LR18P-1	E*1P29B	95G1UH045BE12	15.1	13	18000	13000	620
	E*1P29B	95G1UH070BE12	15.1	13	18000	13000	650
	E*1P29B	95G2UH045BE12	15.1	13	18000	13000	620
	E*1P29B	95G2UH070BE12	15.1	13	18000	13000	650
	E*1P29B	EFV08BC	15.1	13	18000	13000	650
	E*1P30B	80G1UH070BE12	15.1	13	18000	13000	620
	E*1P30B	95G1UH045BE12	15.1	13	18000	13000	620
	E*1P30B	95G1UH070BE12	15.1	13	18000	13000	650
	E*1P30B	95G2UH045BE12	15.1	13	18000	13000	620
	E*1P30B	95G2UH070BE12	15.1	13	18000	13000	650
	E*1P30B	EFV08BC	15.1	13	18000	13000	650
	E*1P36A	80G1UH045AE12	15.1	13	18000	13000	650
	E*1P36B	80G1UH070BE12	15.1	13	18000	13000	620
	E*1P36B	95G1UH045BE12	15.1	13	18000	13000	620
	E*1P36B	95G1UH070BE12	15.1	13	18000	13000	650
	E*1P36B	95G2UH045BE12	15.1	13	18000	13000	620
	E*1P36B	95G2UH070BE12	15.1	13	18000	13000	650
	E*1P36B	EFV08BC	15.1	13	18000	13000	650
	EC4X23B	80G1UH070BE12	15.1	13	18000	13000	650
	EC4X23B	95G1UH070BE12	15.1	13	18000	13000	650
	EC4X23B	95G2UH070BE12	15.1	13	18000	13000	650
	EC4X24A	80G1UH045AE12	15.1	13	18000	13000	650
	EC4X24B	80G1UH070BE12	15.1	13	18000	13000	620
	EC4X24B	95G1UH045BE12	15.1	12.5	18000	13000	635
	EC4X24B	95G2UH045BE12	15.1	12.5	18000	13000	635
	EC4X24B	95G2UH045BV12	15.1	13	18000	13000	650
	EC4X24B	EFV08BC	15.1	13	18000	13000	650
	EC4X29A	80G1UH045AE12	15.1	13	18000	13000	650
	EC4X29B	80G1UH070BE12	15.1	13	18000	13000	620
	EC4X29B	95G1UH070BE12	15.1	13	18000	13000	650
	EC4X29B	95G2UH070BE12	15.1	13	18000	13000	650
	EC4X29B	EFV08BC	15.1	13	18000	13000	650
	EC4X30B	80G1UH070BE12	15.1	13	18000	13000	620
	EC4X30B	95G1UH045BE12	15.1	13	18000	13000	620
	EC4X30B	95G1UH070BE12	15.1	13	18000	13000	650
	EC4X30B	95G2UH045BE12	15.1	13	18000	13000	620
	EC4X30B	95G2UH070BE12	15.1	13	18000	13000	650
	EC4X30B	EFV08BC	15.1	13	18000	13000	650
	EC4X36A	80G1UH045AE12	15.1	13	18000	13000	650
	EC4X36B	80G1UH070BE12	15.1	13	18000	13000	620

Note:

1 Certified in accordance with Unitary Air Conditioner Certification Program, which is based on AHRI Standard 210/240

2 Required to achieve AHRI rating. If NA (Not Applicable) is in the piston column, then TXV is required

3 A blower time delay relay is required to achieve AHRI rating. This feature is standard on all Allied Air Enterprises furnace and AH products.

COOLING PERFORMANCE WITH AIR HANDLERS AND FURNACES

Outdoor Unit	Indoor Model	Furnace Model	SEER	EER	AHRI Rated Capacity BTUH	Sensible Capacity	CFM
	Evap Coil						
4AC16LR18P-1	EC4X36B	95G1UH045BE12	15.1	13	18000	13000	620
	EC4X36B	95G1UH070BE12	15.1	13	18000	13000	650
	EC4X36B	95G2UH045BE12	15.1	13	18000	13000	620
	EC4X36B	95G2UH070BE12	15.1	13	18000	13000	650
	EC4X36B	EFV08BC	15.1	13	18000	13000	650
	E*1P24B	95G1UH070BE12	14.5	12.2	18000	13000	650
	E*1P24B	95G2UH070BE12	14.5	12.2	18000	13000	650
	EC4X24B	95G1UH070BE12	14.5	12.2	18000	13000	650
	EC4X24B	95G2UH070BE12	14.5	12.2	18000	13000	650
	ED1P18A+H4TXV01	80G1DF045AE12	14	12.2	18000	13000	625
	ED1P24A+H4TXV01	80G1DF045AE12	14	12.2	18000	13000	625
	ED1P24B+H4TXV01	80G1DF070BE12	14	12.2	18000	13000	645
4AC16LR24P-1	BCE3M36E****4X		16	13	23000	17000	850
	BCE3M36V****4X		16	13	23000	17000	820
	BCE3M30E****4X		15.1	13	23000	17000	850
	BCE3M24V****4X		15	12.5	23000	17000	820
	BCE3M30V****4X		15	12.5	23000	17000	800
	BCE3M24C****P		14	12.2	23000	17000	850
	E*1P19A	80G2UH070AV12	16	13	23000	17000	850
	E*1P23B	95G2UH045BV12	16	13	23000	17000	850
	E*1P23B	95G2UH070BE12	16	13	23000	17000	800
	E*1P23B+TXV	95G1UH045BE12	16	13	23000	17000	785
	E*1P23B+TXV	95G1UH070BE12	16	13	23000	17000	835
	E*1P23B+TXV	95G2UH045BE12	16	13	23000	17000	785
	E*1P23B+TXV	95G2UH070BE12	16	13	23000	17000	835
	E*1P24A	80G2UH070AV12	16	13	23000	17000	850
	E*1P24B	80G1UH070BE12	16	13	23000	17000	800
	E*1P29B+TXV	95G1UH045BE12	16	13	23000	17000	785
	E*1P29B+TXV	95G1UH070BE12	16	13	23000	17000	835
	E*1P29B+TXV	95G2UH045BE12	16	13	23000	17000	785
	E*1P29B+TXV	95G2UH070BE12	16	13	23000	17000	835
	E*1P30B	80G2UH090BV16	16	13	23000	17000	800
	E*1P30B	95G1UH070BE12	16	13	23000	17000	800
	E*1P30B	95G2UH045BV12	16	13	23000	17000	850
	E*1P36A	80G2UH070AV12	16	13	23000	17000	850
	E*1P36B	95G1UH045BE12	16	13	23000	17000	760
E*1P36B+TXV	95G1UH045BE12	16	13	23000	17000	785	
E*1P36B+TXV	95G1UH070BE12	16	13	23000	17000	835	
E*1P36B+TXV	95G2UH045BE12	16	13	23000	17000	785	
E*1P36B+TXV	95G2UH070BE12	16	13	23000	17000	835	

Note:

1 Certified in accordance with Unitary Air Conditioner Certification Program, which is based on AHRI Standard 210/240

2 Required to achieve AHRI rating. If NA (Not Applicable) is in the piston column, then TXV is required

3 A blower time delay relay is required to achieve AHRI rating. This feature is standard on all Allied Air Enterprises furnace and AH products.

COOLING PERFORMANCE WITH AIR HANDLERS AND FURNACES

Outdoor Unit	Indoor Model	Furnace Model	SEER	EER	AHRI Rated Capacity BTUH	Sensible Capacity	CFM
	Evap Coil						
4AC16LR24P-1	E*1P36C	95G2UH090CV12	16	13	23000	17000	850
	EC4X23B	95G1UH045BE12	16	13	23000	17000	785
	EC4X23B	95G1UH070BE12	16	13	23000	17000	835
	EC4X23B	95G2UH045BE12	16	13	23000	17000	785
	EC4X23B	95G2UH045BV12	16	13	23000	17000	850
	EC4X23B	95G2UH070BE12	16	13	23000	17000	835
	EC4X24A	80G2UH070AV12	16	13	23000	17000	850
	EC4X24B	80G1UH070BE12	16	13	23000	17000	800
	EC4X29B	95G1UH045BE12	16	13	23000	17000	785
	EC4X29B	95G1UH070BE12	16	13	23000	17000	835
	EC4X29B	95G2UH045BE12	16	13	23000	17000	785
	EC4X29B	95G2UH070BE12	16	13	23000	17000	835
	EC4X30B	80G2UH090BV16	16	13	23000	17000	800
	EC4X30B	95G1UH070BE12	16	13	23000	17000	800
	EC4X30B	95G2UH045BV12	16	13	23000	17000	850
	EC4X36A	80G2UH070AV12	16	13	23000	17000	850
	EC4X36B	95G1UH045BE12	16	13	23000	17000	785
	EC4X36B	95G1UH070BE12	16	13	23000	17000	835
	EC4X36B	95G2UH045BE12	16	13	23000	17000	785
	EC4X36B	95G2UH070BE12	16	13	23000	17000	835
	EC4X36C	95G2UH090CV12	16	13	23000	17000	850
	E*1P24B+TXV	95G1UH070BE12	15.5	12.5	23000	17000	795
	E*1P24B+TXV	95G2UH070BE12	15.5	12.5	23000	17000	795
	EC4X24B	95G1UH070BE12	15.5	12.5	23000	17000	795
	EC4X24B	95G2UH070BE12	15.5	12.5	23000	17000	795
	E*1P19A	80G1UH045AE12	15.1	13	23000	17000	850
	E*1P23A	80G1UH045AE12	15.1	13	23000	17000	850
	E*1P23A	80G2UH070AV12	15.1	13	23000	17000	850
	E*1P23B	80G1UH070BE12	15.1	13	23000	17000	800
	E*1P23B	80G2UH070AV12	15.1	13	23000	17000	850
	E*1P23B	80G2UH090BV16	15.1	12.5	23000	17000	800
	E*1P23B	95G1UH045BE12	15.1	13	23000	17000	760
	E*1P23B	95G1UH070BE12	15.1	12.5	23000	17000	800
	E*1P23B	95G2UH070BV12	15.1	13	23000	17000	850
	E*1P23B	EFV08BC	15.1	12.5	23000	17000	850
	E*1P29A	80G2UH070AV12	15.1	13	23000	17000	850
E*1P29B	80G1UH070BE12	15.1	13	23000	17000	800	
E*1P29B	80G2UH090BV16	15.1	13	23000	17000	800	
E*1P29B	95G1UH070BE12	15.1	13	23000	17000	800	
E*1P29B	95G2UH045BV12	15.1	13	23000	17000	850	

Note:

1 Certified in accordance with Unitary Air Conditioner Certification Program, which is based on AHRI Standard 210/240

2 Required to achieve AHRI rating. If NA (Not Applicable) is in the piston column, then TXV is required

3 A blower time delay relay is required to achieve AHRI rating. This feature is standard on all Allied Air Enterprises furnace and AH products.

COOLING PERFORMANCE WITH AIR HANDLERS AND FURNACES

Outdoor Unit	Indoor Model	Furnace Model	SEER	EER	AHRI Rated Capacity BTUH	Sensible Capacity	CFM
	Evap Coil						
4AC16LR24P-1	E*1P29B	95G2UH070BE12	15.1	13	23000	17000	800
	E*1P29B	95G2UH070BV12	15.1	13	23000	17000	850
	E*1P29B	EFV08BC	15.1	12.5	23000	17000	850
	E*1P30A	80G2UH070AV12	15.1	13	23000	17000	850
	E*1P30B	80G1UH070BE12	15.1	13	23000	17000	800
	E*1P30B	95G2UH070BE12	15.1	12.5	23000	17000	800
	E*1P30B	95G2UH070BV12	15.1	12.5	23000	17000	850
	E*1P30C	95G2UH090CV12	15.1	13	23000	17000	850
	E*1P36B	80G1UH070BE12	15.1	13	23000	17000	820
	E*1P36B	80G2UH090BV16	15.1	13	23000	17000	800
	E*1P36B	95G1UH070BE12	15.1	13	23000	17000	800
	E*1P36B	95G2UH045BV12	15.1	13	23000	17000	850
	E*1P36B	95G2UH070BE12	15.1	13	23000	17000	800
	E*1P36B	95G2UH070BV12	15.1	13	23000	17000	850
	E*1P36B	EFV08BC	15.1	13	23000	17000	850
	EC4X23A	80G1UH045AE12	15.1	13	23000	17000	850
	EC4X23A	80G2UH070AV12	15.1	13	23000	17000	850
	EC4X23B	80G1UH070BE12	15.1	13	23000	17000	800
	EC4X23B	80G2UH070AV12	15.1	13	23000	17000	850
	EC4X23B	80G2UH090BV16	15.1	12.5	23000	17000	800
	EC4X23B	95G2UH070BV12	15.1	13	23000	17000	850
	EC4X23B	EFV08BC	15.1	12.5	23000	17000	850
	EC4X29A	80G2UH070AV12	15.1	13	23000	17000	850
	EC4X29B	80G1UH070BE12	15.1	13	23000	17000	800
	EC4X29B	80G2UH090BV16	15.1	13	23000	17000	800
	EC4X29B	95G2UH045BV12	15.1	13	23000	17000	850
	EC4X29B	95G2UH070BV12	15.1	13	23000	17000	850
	EC4X29B	EFV08BC	15.1	12.5	23000	17000	850
	EC4X30A	80G2UH070AV12	15.1	13	23000	17000	850
	EC4X30B	80G1UH070BE12	15.1	13	23000	17000	800
	EC4X30B	95G2UH070BE12	15.1	12.5	23000	17000	800
	EC4X30B	95G2UH070BV12	15.1	12.5	23000	17000	850
	EC4X30C	95G2UH090CV12	15.1	13	23000	17000	850
	EC4X36B	80G1UH070BE12	15.1	13	23000	17000	820
	EC4X36B	80G2UH090BV16	15.1	13	23000	17000	800
	EC4X36B	95G2UH045BV12	15.1	13	23000	17000	850
	EC4X36B	95G2UH070BV12	15.1	13	23000	17000	850
	EC4X36B	EFV08BC	15.1	13	23000	17000	850
	ED1P24A+H4TXV01	80G1DF045AE12	15	12.5	23000	17000	835
	ED1P24B+H4TXV01	80G1DF070BE12	15	12.5	23000	17000	755

Note:

1 Certified in accordance with Unitary Air Conditioner Certification Program, which is based on AHRI Standard 210/240

2 Required to achieve AHRI rating. If NA (Not Applicable) is in the piston column, then TXV is required

3 A blower time delay relay is required to achieve AHRI rating. This feature is standard on all Allied Air Enterprises furnace and AH products.

COOLING PERFORMANCE WITH AIR HANDLERS AND FURNACES

Outdoor Unit	Indoor Model	Furnace Model	SEER	EER	AHRI Rated Capacity BTUH	Sensible Capacity	CFM
	Evap Coil						
4AC16LR24P-1	ED1P24B+H4TXV01	95G1DF045BE12	15	12.5	22000	17000	730
	ED1P24B+H4TXV01	95G1DF070BE16	15	12.5	22000	17000	740
	ED1P24B+H4TXV01	95G2DF045BE12	15	12.5	22000	17000	730
	ED1P24B+H4TXV01	95G2DF045BV12	15	12.5	23000	17000	805
	ED1P24B+H4TXV01	95G2DF070BE16	15	12.5	22000	17000	740
	ED1P24B+H4TXV01	95G2DF070BV16	15	12.5	23000	17000	860
	ED1P30/36A+H4TXV01	80G1DF045AE12	15	12.5	24000	17000	835
	ED1P30/36B+H4TXV01	80G1DF070BE12	15	12.5	24000	17000	790
	ED1P30/36B+H4TXV01	95G1DF045BE12	15	12.5	24000	17000	735
	ED1P30/36B+H4TXV01	95G1DF070BE16	15	12.5	24000	17000	775
	ED1P30/36B+H4TXV01	95G2DF045BE12	15	12.5	24000	17000	735
	ED1P30/36B+H4TXV01	95G2DF045BV12	15	12.5	24000	17000	805
	ED1P30/36B+H4TXV01	95G2DF070BE16	15	12.5	24000	17000	775
	ED1P30/36B+H4TXV01	95G2DF070BV16	15	12.5	24000	17000	880
	E*1P24B	80G2UH090BV16	14.5	12.2	23000	17000	800
	E*1P24B	95G1UH070BE12	14.5	12.2	23000	17000	800
	E*1P24B	95G2UH045BV12	14.5	12.2	23000	17000	850
	E*1P24B	95G2UH070BE12	14.5	12.2	23000	17000	800
	E*1P24B	95G2UH070BV12	14.5	12.2	23000	17000	850
	E*1P24B	EFV08BC	14.5	12.2	23000	17000	850
	E*1P30B	EFV08BC	14.5	12.2	23000	17000	850
	EC4X24B	80G2UH090BV16	14.5	12.2	23000	17000	800
	EC4X24B	95G2UH045BV12	14.5	12.2	23000	17000	850
	EC4X24B	95G2UH070BV12	14.5	12.2	23000	17000	850
	EC4X24B	EFV08BC	14.5	12.2	23000	17000	850
	EC4X30B	EFV08BC	14.5	12.2	23000	17000	850
E*1P36B	95G2UH045BE12	14	12.2	23000	17000	850	
4AC16LR30P-1	BCE3M36E****4X		15.5	13	28000	21000	1000
	BCE3M30E****4X		15.1	13	28000	21000	1000
	BCE3M30V****4X		15	12.5	28000	21000	1000
	BCE3M30C****P		14	12.2	28000	21000	1000
	E*1P36B	80G2UH090BV16	16	13	28000	21000	1000
	E*1P36B	95G2UH070BV12	16	13	28000	21000	960
	E*1P36C	95G2UH090CV12	16	13	28000	21000	1000
	E*1P43C+TXV	95G1UH090CE16	16	13	28000	21000	945
	E*1P43C+TXV	95G2UH090CE16	16	13	28000	21000	945
	EC4X36B	80G2UH090BV16	16	13	28000	21000	1000
	EC4X36B	95G2UH070BV12	16	13	28000	21000	960
	EC4X36C	95G2UH090CV12	16	13	28000	21000	1000
	EC4X43C	95G1UH090CE16	16	13	28000	21000	945

Note:

1 Certified in accordance with Unitary Air Conditioner Certification Program, which is based on AHRI Standard 210/240

2 Required to achieve AHRI rating. If NA (Not Applicable) is in the piston column, then TXV is required

3 A blower time delay relay is required to achieve AHRI rating. This feature is standard on all Allied Air Enterprises furnace and AH products.

COOLING PERFORMANCE WITH AIR HANDLERS AND FURNACES

Outdoor Unit	Indoor Model	Furnace Model	SEER	EER	AHRI Rated Capacity BTUH	Sensible Capacity	CFM
	Evap Coil						
4AC16LR30P-1	EC4X43C	95G2UH090CE16	16	13	28000	21000	945
	E*1P29B+TXV	95G1UH045BE12	15.5	12.5	28000	21000	1015
	E*1P29B+TXV	95G2UH045BE12	15.5	12.5	28000	21000	1015
	E*1P36B+TXV	95G1UH045BE12	15.5	12.5	28000	21000	1015
	E*1P36B+TXV	95G1UH070BE12	15.5	12.5	28000	21000	1045
	E*1P36B+TXV	95G2UH045BE12	15.5	12.5	28000	21000	1015
	E*1P36B+TXV	95G2UH070BE12	15.5	12.5	28000	21000	1045
	EC4X29B	95G1UH045BE12	15.5	12.5	28000	21000	1015
	EC4X29B	95G2UH045BE12	15.5	12.5	28000	21000	1015
	EC4X36B	95G1UH045BE12	15.5	12.5	28000	21000	1015
	EC4X36B	95G1UH070BE12	15.5	12.5	28000	21000	1045
	EC4X36B	95G2UH045BE12	15.5	12.5	28000	21000	1015
	EC4X36B	95G2UH070BE12	15.5	12.5	28000	21000	1045
	E*1P23A	80G2UH070AV12	15.1	13	28000	21000	1000
	E*1P29A	80G2UH070AV12	15.1	13	28000	21000	1000
	E*1P29B	80G1UH070BE12	15.1	13	28000	21000	1000
	E*1P29B	80G1UH090BE16	15.1	13	28000	21000	1000
	E*1P29B	80G2UH090BV16	15.1	13	28000	21000	1000
	E*1P29B	95G1UH045BE12	15.1	13	28000	21000	1000
	E*1P29B	95G1UH070BE12	15.1	13	28000	21000	1000
	E*1P29B	95G2UH045BE12	15.1	13	28000	21000	1000
	E*1P29B	95G2UH045BV12	15.1	13	28000	21000	980
	E*1P29B	95G2UH070BE12	15.1	13	28000	21000	1000
	E*1P29B	95G2UH070BV12	15.1	13	28000	21000	960
	E*1P29B+TXV	95G1UH070BE12	15.1	12.5	28000	21000	995
	E*1P29B+TXV	95G2UH070BE12	15.1	12.5	28000	21000	995
	E*1P30A	80G2UH070AV12	15.1	13	28000	21000	1000
	E*1P30B	80G1UH070BE12	15.1	13	28000	21000	1000
	E*1P30B	80G1UH090BE16	15.1	13	28000	21000	1000
	E*1P30B	80G2UH090BV16	15.1	13	28000	21000	1000
	E*1P30B	95G2UH045BV12	15.1	13	28000	21000	980
	E*1P30B	95G2UH070BV12	15.1	13	28000	21000	960
	E*1P30B+TXV	95G1UH045BE12	15.1	12.5	28000	21000	1015
	E*1P30B+TXV	95G1UH070BE12	15.1	12.5	28000	21000	1045
	E*1P30B+TXV	95G2UH045BE12	15.1	12.5	28000	21000	1015
	E*1P30B+TXV	95G2UH070BE12	15.1	12.5	28000	21000	1045
	E*1P30C+TXV	95G1UH090CE16	15.1	12.5	28000	21000	1005
	E*1P30C+TXV	95G2UH090CE16	15.1	12.5	28000	21000	1005
	E*1P36A	80G2UH070AV12	15.1	13	28000	21000	1000
	E*1P36B	80G1UH070BE12	15.1	13	28000	21000	1000

Note:

1 Certified in accordance with Unitary Air Conditioner Certification Program, which is based on AHRI Standard 210/240

2 Required to achieve AHRI rating. If NA (Not Applicable) is in the piston column, then TXV is required

3 A blower time delay relay is required to achieve AHRI rating. This feature is standard on all Allied Air Enterprises furnace and AH products.

COOLING PERFORMANCE WITH AIR HANDLERS AND FURNACES

Outdoor Unit	Indoor Model	Furnace Model	SEER	EER	AHRI Rated Capacity BTUH	Sensible Capacity	CFM
	Evap Coil						
4AC16LR30P-1	E*1P36B	80G1UH090BE16	15.1	13	28000	21000	1000
	E*1P36B	95G1UH045BE12	15.1	13	28000	21000	1000
	E*1P36B	95G1UH070BE12	15.1	13	28000	21000	1000
	E*1P36B	95G2UH045BE12	15.1	13	28000	21000	1015
	E*1P36B	95G2UH045BV12	15.1	13	28000	21000	980
	E*1P36B	95G2UH070BE12	15.1	13	28000	21000	995
	E*1P36C	95G1UH090CE16	15.1	13	28000	21000	1000
	E*1P48B	80G1UH070BE12	15.1	13	28000	21000	1000
	E*1P48B	80G1UH090BE16	15.1	13	28000	21000	1000
	E*1P48B	80G2UH090BV16	15.1	13	28000	21000	1000
	E*1P48B	95G1UH045BE12	15.1	13	28000	21000	1000
	E*1P48B	95G1UH070BE12	15.1	13	28000	21000	1000
	E*1P48B	95G2UH045BE12	15.1	13	28000	21000	1000
	E*1P48B	95G2UH045BV12	15.1	13	28000	21000	980
	E*1P48B	95G2UH070BE12	15.1	13	28000	21000	1000
	E*1P48B	95G2UH070BV12	15.1	13	28000	21000	960
	E*1P48C	95G1UH090CE16	15.1	13	28000	21000	1000
	E*1P48C	95G2UH090CE16	15.1	13	28000	21000	1000
	EC4X23A	80G2UH070AV12	15.1	13	28000	21000	1000
	EC4X29A	80G2UH070AV12	15.1	13	28000	21000	1000
	EC4X29B	80G1UH070BE12	15.1	13	28000	21000	1000
	EC4X29B	80G1UH090BE16	15.1	13	28000	21000	1000
	EC4X29B	80G2UH090BV16	15.1	13	28000	21000	1000
	EC4X29B	95G1UH070BE12	15.1	12.5	28000	21000	995
	EC4X29B	95G2UH045BV12	15.1	13	28000	21000	980
	EC4X29B	95G2UH070BE12	15.1	12.5	28000	21000	995
	EC4X29B	95G2UH070BV12	15.1	13	28000	21000	960
	EC4X30A	80G2UH070AV12	15.1	13	28000	21000	1000
	EC4X30B	80G1UH070BE12	15.1	13	28000	21000	1000
	EC4X30B	80G1UH090BE16	15.1	13	28000	21000	1000
	EC4X30B	80G2UH090BV16	15.1	13	28000	21000	1000
	EC4X30B	95G1UH045BE12	15.1	12.5	28000	21000	1015
	EC4X30B	95G1UH070BE12	15.1	12.5	28000	21000	1045
	EC4X30B	95G2UH045BE12	15.1	12.5	28000	21000	1015
	EC4X30B	95G2UH045BV12	15.1	13	28000	21000	980
	EC4X30B	95G2UH070BE12	15.1	12.5	28000	21000	1045
EC4X30B	95G2UH070BV12	15.1	13	28000	21000	960	
EC4X30C	95G1UH090CE16	15.1	12.5	28000	21000	1005	
EC4X30C	95G2UH090CE16	15.1	12.5	28000	21000	1005	
EC4X36A	80G2UH070AV12	15.1	13	28000	21000	1000	

Note:
 1 Certified in accordance with Unitary Air Conditioner Certification Program, which is based on AHRI Standard 210/240
 2 Required to achieve AHRI rating. If NA (Not Applicable) is in the piston column, then TXV is required
 3 A blower time delay relay is required to achieve AHRI rating. This feature is standard on all Allied Air Enterprises furnace and AH products.

COOLING PERFORMANCE WITH AIR HANDLERS AND FURNACES

Outdoor Unit	Indoor Model	Furnace Model	SEER	EER	AHRI Rated Capacity BTUH	Sensible Capacity	CFM
	Evap Coil						
4AC16LR30P-1	EC4X36B	80G1UH070BE12	15.1	13	28000	21000	1000
	EC4X36B	80G1UH090BE16	15.1	13	28000	21000	1000
	EC4X36B	95G2UH045BV12	15.1	13	28000	21000	980
	EC4X36C	95G1UH090CE16	15.1	13	28000	21000	1000
	EC4X48B	80G1UH070BE12	15.1	13	28000	21000	1000
	EC4X48B	80G1UH090BE16	15.1	13	28000	21000	1000
	EC4X48B	80G2UH090BV16	15.1	13	28000	21000	1000
	EC4X48B	95G1UH045BE12	15.1	13	28000	21000	1000
	EC4X48B	95G1UH070BE12	15.1	13	28000	21000	1000
	EC4X48B	95G2UH045BE12	15.1	13	28000	21000	1000
	EC4X48B	95G2UH045BV12	15.1	13	28000	21000	980
	EC4X48B	95G2UH070BE12	15.1	13	28000	21000	1000
	EC4X48B	95G2UH070BV12	15.1	13	28000	21000	960
	EC4X48C	95G1UH090CE16	15.1	13	28000	21000	1000
	EC4X48C	95G2UH090CE16	15.1	13	28000	21000	1000
	ED1P30/36A+H4TXV01	80G1DF045AE12	15	12.5	28000	21000	1000
	ED1P30/36B+H4TXV01	80G1DF070BE12	15	12.5	28000	21000	985
	ED1P30/36B+H4TXV01	80G1DF090BE16	15	12.5	28000	21000	945
	ED1P30/36B+H4TXV01	95G1DF045BE12	15	12.5	28000	21000	985
	ED1P30/36B+H4TXV01	95G1DF070BE16	15	12.5	28000	21000	1015
	ED1P30/36B+H4TXV01	95G2DF045BE12	15	12.5	28000	21000	985
	ED1P30/36B+H4TXV01	95G2DF045BV12	15	12.5	28000	21000	1000
	ED1P30/36B+H4TXV01	95G2DF070BE16	15	12.5	28000	21000	1015
	ED1P30/36B+H4TXV01	95G2DF070BV16	15	12.5	28000	21000	995
	E*1P19A	80G1UH045AE12	14.5	12.2	28000	21000	1000
	E*1P19A	80G2UH070AV12	14.5	12.2	28000	21000	1000
	E*1P23A	80G1UH045AE12	14.5	12.2	28000	21000	1000
	E*1P29B	EFV12BC	14.5	12.2	28000	21000	1000
	E*1P30A	80G1UH045AE12	14.5	12.2	28000	21000	1000
	E*1P30B	95G1UH045BE12	14.5	12.2	28000	21000	1000
	E*1P30B	95G1UH070BE12	14.5	12.2	28000	21000	1000
	E*1P30B	95G2UH045BE12	14.5	12.2	28000	21000	1000
	E*1P30B	95G2UH070BE12	14.5	12.2	28000	21000	1000
	E*1P30C	95G1UH090CE16	14.5	12.2	28000	21000	1000
	E*1P30C	95G2UH090CE16	14.5	12.2	28000	21000	1000
	E*1P36B	EFV12BC	14.5	12.2	28000	21000	1000
	E*1P36C	95G2UH090CE16	14.5	12.2	28000	21000	1000
	E*1P48B	EFV12BC	14.5	12.2	28000	21000	1000
	EC4X23A	80G1UH045AE12	14.5	12.2	28000	21000	1000
	EC4X29B	EFV12BC	14.5	12.2	28000	21000	1000

Note:

1 Certified in accordance with Unitary Air Conditioner Certification Program, which is based on AHRI Standard 210/240

2 Required to achieve AHRI rating. If NA (Not Applicable) is in the piston column, then TXV is required

3 A blower time delay relay is required to achieve AHRI rating. This feature is standard on all Allied Air Enterprises furnace and AH products.

COOLING PERFORMANCE WITH AIR HANDLERS AND FURNACES

Outdoor Unit	Indoor Model	Furnace Model	SEER	EER	AHRI Rated Capacity BTUH	Sensible Capacity	CFM
	Evap Coil						
4AC16LR30P-1	EC4X30A	80G1UH045AE12	14.5	12.2	28000	21000	1000
	EC4X36B	EFV12BC	14.5	12.2	28000	21000	1000
	EC4X36C	95G2UH090CE16	14.5	12.2	28000	21000	1000
	EC4X48B	EFV12BC	14.5	12.2	28000	21000	1000
	E*1P30B	EFV12BC	14.25	12.2	27800	21000	1000
	EC4X30B	EFV12BC	14.25	12.2	27800	21000	1000
	ED1P24A+H4TXV01	80G1DF045AE12	14	12.2	26000	21000	970
	ED1P24B+H4TXV01	80G1DF070BE12	14	12.2	26000	21000	970
	ED1P24B+H4TXV01	95G2DF045BV12	14	12.2	26000	21000	965
4AC16LR36P-1	BCE3M42E****4X		16	13	34000	25500	1200
	BCE3M42V****4X		16	13	34000	25500	1200
	BCE3M48E****4X		16	13	34000	25500	1200
	BCE3M36V****4X		14.5	12.2	34000	25500	1200
	BCE3M36C****P		14	12.2	34000	25500	1200
	BCE3M36E****4X		14	12.2	34000	25500	1200
	E*1P36B	80G2UH090BV16	16	13	34000	25500	1200
	E*1P43B	80G2UH090BV16	16	13	34000	25500	1200
	E*1P43C+TXV	95G2UH110CE20	16	13	34000	25500	1215
	E*1P49C+TXV	95G1UH090CE16	16	13	34000	25500	1155
	E*1P49C+TXV	95G1UH110CE20	16	13	34000	25500	1215
	E*1P49C+TXV	95G2UH090CE16	16	13	34000	25500	1155
	E*1P49C+TXV	95G2UH110CE20	16	13	34000	25500	1215
	EC4X36B	80G2UH090BV16	16	13	34000	25500	1200
	EC4X43B	80G2UH090BV16	16	13	34000	25500	1200
	EC4X43C	95G2UH110CE20	16	13	34000	25500	1215
	EC4X49C	95G1UH090CE16	16	13	34000	25500	1155
	EC4X49C	95G1UH110CE20	16	13	34000	25500	1215
	EC4X49C	95G2UH090CE16	16	13	34000	25500	1155
	EC4X49C	95G2UH110CE20	16	13	34000	25500	1215
	E*1P29B	80G2UH090BV16	15.1	13	34000	25500	1200
	E*1P29B+TXV	95G1UH070BE12	15.1	12.5	34000	25500	1145
	E*1P29B+TXV	95G2UH070BE12	15.1	12.5	34000	25500	1145
	E*1P36B	80G1UH090BE16	15.1	12.5	34000	25500	1180
	E*1P36B	95G2UH045BV12	15.1	13	34000	25500	1200
	E*1P36B	95G2UH070BV12	15.1	13	34000	25500	1200
	E*1P36B	EFV12BC	15.1	13	34000	25500	1200
	E*1P36C	80G1UH090CE20	15.1	13	34000	25500	1200
	E*1P36C	95G1UH090CE16	15.1	13	34000	25500	1200
	E*1P36C	95G2UH110CE20	15.1	13	34000	25500	1200
E*1P36C	EFV16CC	15.1	13	34000	25500	1200	

Note:

1 Certified in accordance with Unitary Air Conditioner Certification Program, which is based on AHRI Standard 210/240

2 Required to achieve AHRI rating. If NA (Not Applicable) is in the piston column, then TXV is required

3 A blower time delay relay is required to achieve AHRI rating. This feature is standard on all Allied Air Enterprises furnace and AH products.

COOLING PERFORMANCE WITH AIR HANDLERS AND FURNACES

Outdoor Unit	Indoor Model	Furnace Model	SEER	EER	AHRI Rated Capacity BTUH	Sensible Capacity	CFM
	Evap Coil						
4AC16LR36P-1	E*1P43B	80G1UH090BE16	15.1	12.5	34000	25500	1180
	E*1P43B	95G1UH070BE12	15.1	12.2	34000	25500	1200
	E*1P43B	95G2UH045BV12	15.1	13	34000	25500	1200
	E*1P43B	95G2UH070BE12	15.1	13	34000	25500	1200
	E*1P43B	EFV12BC	15.1	13	34000	25500	1200
	E*1P43B+TXV	95G1UH070BE12	15.1	12.5	34000	25500	1215
	E*1P43B+TXV	95G2UH070BE12	15.1	12.5	34000	25500	1215
	E*1P43C	80G1UH090CE20	15.1	12.5	34000	25500	1200
	E*1P43C	95G2UH110CE20	15.1	13	34000	25500	1200
	E*1P43C	EFV16CC	15.1	13	34000	25500	1200
	EC4X29B	80G2UH090BV16	15.1	13	34000	25500	1200
	EC4X29B	95G1UH070BE12	15.1	12.5	34000	25500	1145
	EC4X29B	95G2UH070BE12	15.1	12.5	34000	25500	1145
	EC4X36B	80G1UH090BE16	15.1	12.5	34000	25500	1180
	EC4X36B	95G2UH045BV12	15.1	13	34000	25500	1200
	EC4X36B	95G2UH070BV12	15.1	13	34000	25500	1200
	EC4X36B	EFV12BC	15.1	13	34000	25500	1200
	EC4X36C	80G1UH090CE20	15.1	13	34000	25500	1200
	EC4X36C	95G1UH090CE16	15.1	13	34000	25500	1200
	EC4X36C	95G2UH110CE20	15.1	13	34000	25500	1200
	EC4X36C	EFV16CC	15.1	13	34000	25500	1200
	EC4X43B	80G1UH090BE16	15.1	12.5	34000	25500	1180
	EC4X43B	95G1UH070BE12	15.1	12.5	34000	25500	1215
	EC4X43B	95G2UH045BV12	15.1	13	34000	25500	1200
	EC4X43B	95G2UH070BE12	15.1	12.5	34000	25500	1215
	EC4X43B	EFV12BC	15.1	13	34000	25500	1200
	EC4X43C	80G1UH090CE20	15.1	12.5	34000	25500	1200
	EC4X43C	EFV16CC	15.1	13	34000	25500	1200
	E*1P36B+TXV	95G1UH070BE12	15	12.5	34000	25500	1215
	E*1P36B+TXV	95G2UH070BE12	15	12.5	34000	25500	1215
	E*1P43B+TXV	95G1UH045BE12	15	12.5	34000	25500	1215
	E*1P43B+TXV	95G2UH045BE12	15	12.5	34000	25500	1215
	EC4X36B	95G1UH070BE12	15	12.5	34000	25500	1215
	EC4X36B	95G2UH070BE12	15	12.5	34000	25500	1215
	EC4X43B	95G1UH045BE12	15	12.5	34000	25500	1215
	EC4X43B	95G2UH045BE12	15	12.5	34000	25500	1215
ED1P30/36B+H4TXV01	80G1DF070BE12	15	12.5	33000	25500	1110	
ED1P30/36B+H4TXV01	80G1DF090BE16	15	12.5	33000	25500	1165	
ED1P30/36B+H4TXV01	95G1DF070BE16	15	12.5	33000	25500	1155	
ED1P30/36B+H4TXV01	95G2DF070BE16	15	12.5	33000	25500	1155	

Note:

1 Certified in accordance with Unitary Air Conditioner Certification Program, which is based on AHRI Standard 210/240

2 Required to achieve AHRI rating. If NA (Not Applicable) is in the piston column, then TXV is required

3 A blower time delay relay is required to achieve AHRI rating. This feature is standard on all Allied Air Enterprises furnace and AH products.

COOLING PERFORMANCE WITH AIR HANDLERS AND FURNACES

Outdoor Unit	Indoor Model	Furnace Model	SEER	EER	AHRI Rated Capacity BTUH	Sensible Capacity	CFM
	Evap Coil						
4AC16LR36P-1	ED1P48B+H4TXV02	80G1DF070BE12	15	12.5	34000	25500	1220
	ED1P48B+H4TXV02	80G1DF090BE16	15	12.5	34000	25500	1165
	ED1P48B+H4TXV02	95G1DF045BE12	15	12.5	34000	25500	1150
	ED1P48B+H4TXV02	95G1DF070BE16	15	12.5	34000	25500	1155
	ED1P48B+H4TXV02	95G2DF045BE12	15	12.5	34000	25500	1150
	ED1P48B+H4TXV02	95G2DF045BV12	15	12.5	34000	25500	1210
	ED1P48B+H4TXV02	95G2DF070BE16	15	12.5	34000	25500	1155
	ED1P48B+H4TXV02	95G2DF070BV16	15	12.5	34000	25500	1230
	ED1P48C+H4TXV02	95G1DF090CE16	15	12.5	34000	25500	1185
	ED1P48C+H4TXV02	95G1DF110CE20	15	12.5	34000	25500	1190
	ED1P48C+H4TXV02	95G2DF090CE16	15	12.5	34000	25500	1185
	ED1P48C+H4TXV02	95G2DF090CV20	15	12.5	34000	25500	1270
	ED1P48C+H4TXV02	95G2DF110CE20	15	12.5	34000	25500	1190
	ED1P48C+H4TXV02	95G2DF110CV20	15	12.5	34000	25500	1275
	E*1P29B	80G1UH090BE16	14.5	12.2	34000	25500	1180
	E*1P29B	95G1UH045BE12	14.5	12.2	34000	25500	1190
	E*1P29B	95G1UH070BE12	14.5	12.2	34000	25500	1200
	E*1P29B	95G2UH045BE12	14.5	12.2	34000	25500	1190
	E*1P29B	95G2UH045BV12	14.5	12.2	34000	25500	1200
	E*1P29B	95G2UH070BE12	14.5	12.2	34000	25500	1200
	E*1P29B	95G2UH070BV12	14.5	12.2	34000	25500	1210
	E*1P29B+TXV	95G1UH045BE12	14.5	12.2	34000	25500	1190
	E*1P29B+TXV	95G2UH045BE12	14.5	12.2	34000	25500	1190
	E*1P36B	95G1UH045BE12	14.5	12.2	34000	25500	1200
	E*1P36B	95G1UH070BE12	14.5	12.2	34000	25500	1200
	E*1P36B	95G2UH045BE12	14.5	12.2	34000	25500	1190
	E*1P36B	95G2UH070BE12	14.5	12.2	34000	25500	1200
	E*1P43B	80G1UH070BE12	14.5	12.2	34000	25500	1200
	E*1P43B	95G1UH045BE12	14.5	12.2	34000	25500	1200
	E*1P43B	95G2UH045BE12	14.5	12.2	34000	25500	1190
	E*1P43B	95G2UH070BV12	14.5	12.5	34000	25500	1200
	EC4X29B	80G1UH090BE16	14.5	12.2	34000	25500	1180
	EC4X29B	95G1UH045BE12	14.5	12.2	34000	25500	1190
	EC4X29B	95G2UH045BE12	14.5	12.2	34000	25500	1190
	EC4X29B	95G2UH045BV12	14.5	12.2	34000	25500	1200
	EC4X29B	95G2UH070BV12	14.5	12.2	34000	25500	1210
EC4X36B	95G1UH045BE12	14.5	12.2	34000	25500	1200	
EC4X36B	95G2UH045BE12	14.5	12.2	34000	25500	1190	
EC4X43B	80G1UH070BE12	14.5	12.2	34000	25500	1200	
EC4X43B	95G2UH070BV12	14.5	12.5	34000	25500	1200	

Note:
 1 Certified in accordance with Unitary Air Conditioner Certification Program, which is based on AHRI Standard 210/240
 2 Required to achieve AHRI rating. If NA (Not Applicable) is in the piston column, then TXV is required
 3 A blower time delay relay is required to achieve AHRI rating. This feature is standard on all Allied Air Enterprises furnace and AH products.

COOLING PERFORMANCE WITH AIR HANDLERS AND FURNACES

Outdoor Unit	Indoor Model	Furnace Model	SEER	EER	AHRI Rated Capacity BTUH	Sensible Capacity	CFM
	Evap Coil						
4AC16LR36P-1	ED1P30/36A+H4TXV01	80G1DF045AE12	14	12.2	33000	25500	1215
	ED1P30/36B+H4TXV01	95G2DF045BV12	14	12.2	33000	25500	1210
	ED1P30/36B+H4TXV01	95G2DF070BV16	14	12.2	33000	25500	1230
	ED1P48C+H4TXV02	80G1DF110CE20	14	12.2	33000	25500	1200
4AC16LR42P-1	BCE3M42C****P		14	12.2	40000	30000	1400
	BCE3M42V****4X		15	12.5	41000	30000	1450
	BCE3M42E****4X		14.5	12.2	40000	30000	1400
	BCE3M42C****P+H4TXV02		14	12.2	40000	30000	1400
	BCE3M48E****4X		14	12.2	40000	30000	1400
	E*1P62C+TXV	95G1UH090CE16	16	13	41000	30000	1345
	E*1P62C+TXV	95G1UH110CE20	16	13	41000	30000	1455
	E*1P62C+TXV	95G2UH090CE16	16	13	41000	30000	1345
	E*1P62C+TXV	95G2UH110CE20	16	13	41000	30000	1455
	EC4X62C	95G1UH090CE16	16	13	41000	30000	1345
	EC4X62C	95G1UH110CE20	16	13	41000	30000	1455
	EC4X62C	95G2UH090CE16	16	13	41000	30000	1345
	EC4X62C	95G2UH110CE20	16	13	41000	30000	1455
	E*1P43C+TXV	95G2UH110CE20	15.5	12.5	41000	30000	1465
	E*1P49C+TXV	95G1UH090CE16	15.5	12.5	41000	30000	1355
	E*1P49C+TXV	95G2UH090CE16	15.5	12.5	41000	30000	1355
	E*1P49C+TXV	95G2UH110CE20	15.5	12.5	41000	30000	1460
	EC4X43C	95G2UH110CE20	15.5	12.5	41000	30000	1465
	EC4X49C	95G1UH090CE16	15.5	12.5	41000	30000	1355
	EC4X49C	95G2UH090CE16	15.5	12.5	41000	30000	1355
	EC4X49C	95G2UH110CE20	15.5	12.5	41000	30000	1460
	E*1P43C+H4TXV02	80G1UH090CE20	15.1	13	41000	30000	1400
	E*1P43C+H4TXV02	80G1UH110CE20	15.1	13	41000	30000	1400
	E*1P43C+H4TXV02	95G2UH110CV20	15.1	13	41000	30000	1400
	E*1P49C+H4TXV02	80G1UH090CE20	15.1	13	41000	30000	1400
	E*1P49C+H4TXV02	80G1UH110CE20	15.1	13	41000	30000	1400
	E*1P49C+H4TXV02	80G2UH110CV20	15.1	13	41000	30000	1400
	E*1P49C+H4TXV02	95G2UH090CV20	15.1	12.5	41000	30000	1400
	E*1P49C+H4TXV02	95G2UH110CV20	15.1	12.5	41000	30000	1400
	E*1P62C+H4TXV02	80G1UH090CE20	15.1	13	41000	30000	1400
	E*1P62C+H4TXV02	80G1UH110CE20	15.1	13	41000	30000	1400
	E*1P62C+H4TXV02	80G2UH110CV20	15.1	13	41000	30000	1400
	E*1P62C+H4TXV02	95G2UH090CV20	15.1	13	41000	30000	1400
	E*1P62C+H4TXV02	95G2UH110CE20	15.1	13	41000	30000	1400
	E*1P62C+H4TXV02	95G2UH110CV20	15.1	13	41000	30000	1400
	EC4X43C	80G1UH090CE20	15.1	13	41000	30000	1400

Note:

1 Certified in accordance with Unitary Air Conditioner Certification Program, which is based on AHRI Standard 210/240

2 Required to achieve AHRI rating. If NA (Not Applicable) is in the piston column, then TXV is required

3 A blower time delay relay is required to achieve AHRI rating. This feature is standard on all Allied Air Enterprises furnace and AH products.

COOLING PERFORMANCE WITH AIR HANDLERS AND FURNACES

Outdoor Unit	Indoor Model	Furnace Model	SEER	EER	AHRI Rated Capacity BTUH	Sensible Capacity	CFM
	Evap Coil						
4AC16LR42P-1	EC4X43C	80G1UH110CE20	15.1	13	41000	30000	1400
	EC4X43C	95G2UH110CV20	15.1	13	41000	30000	1400
	EC4X49C	80G1UH090CE20	15.1	13	41000	30000	1400
	EC4X49C	80G1UH110CE20	15.1	13	41000	30000	1400
	EC4X49C	80G2UH110CV20	15.1	13	41000	30000	1400
	EC4X49C	95G2UH090CV20	15.1	12.5	41000	30000	1400
	EC4X49C	95G2UH110CV20	15.1	12.5	41000	30000	1400
	EC4X62C	80G1UH090CE20	15.1	13	41000	30000	1400
	EC4X62C	80G1UH110CE20	15.1	13	41000	30000	1400
	EC4X62C	80G2UH110CV20	15.1	13	41000	30000	1400
	EC4X62C	95G2UH090CV20	15.1	13	41000	30000	1400
	EC4X62C	95G2UH110CV20	15.1	13	41000	30000	1400
	ED1P48C+H4TXV02	80G1DF110CE20	15	12.5	40000	30000	1385
	ED1P48C+H4TXV02	95G1DF090CE16	15	12.5	40000	30000	1340
	ED1P48C+H4TXV02	95G1DF110CE20	15	12.5	40000	30000	1415
	ED1P48C+H4TXV02	95G2DF090CE16	15	12.5	40000	30000	1340
	ED1P48C+H4TXV02	95G2DF110CE20	15	12.5	40000	30000	1415
	ED1P50/60C+H4TXV02	80G1DF110CE20	15	12.5	41000	30000	1425
	ED1P50/60C+H4TXV02	95G1DF090CE16	15	12.5	41000	30000	1365
	ED1P50/60C+H4TXV02	95G1DF110CE20	15	12.5	41000	30000	1450
	ED1P50/60C+H4TXV02	95G2DF090CE16	15	12.5	41000	30000	1365
	ED1P50/60C+H4TXV02	95G2DF090CV20	15	12.5	41000	30000	1450
	ED1P50/60C+H4TXV02	95G2DF110CE20	15	12.5	41000	30000	1450
	ED1P50/60C+H4TXV02	95G2DF110CV20	15	12.5	41000	30000	1440
	E*1P43C+H4TXV02	80G2UH110CV20	14.5	12	41000	30000	1400
	E*1P43C+H4TXV02	95G2UH090CV20	14.5	12	41000	30000	1400
	E*1P43C+H4TXV02	95G2UH110CE20	14.5	12	41000	30000	1400
	E*1P43C+H4TXV02	EFV16CC	14.5	12	41000	30000	1400
	E*1P62C+H4TXV02	EFV16CC	14.5	12.2	41000	30000	1400
	EC4X43C	80G2UH110CV20	14.5	12	41000	30000	1400
	EC4X43C	95G2UH090CV20	14.5	12	41000	30000	1400
	EC4X43C	EFV16CC	14.5	12	41000	30000	1400
EC4X62C	EFV16CC	14.5	12.2	41000	30000	1400	

Note:

1 Certified in accordance with Unitary Air Conditioner Certification Program, which is based on AHRI Standard 210/240

2 Required to achieve AHRI rating. If NA (Not Applicable) is in the piston column, then TXV is required

3 A blower time delay relay is required to achieve AHRI rating. This feature is standard on all Allied Air Enterprises furnace and AH products.

COOLING PERFORMANCE WITH AIR HANDLERS AND FURNACES

Outdoor Unit	Indoor Model	Furnace Model	SEER	EER	AHRI Rated Capacity BTUH	Sensible Capacity	CFM
	Evap Coil						
4AC16LR42P-1	E*1P43C+H4TXV02	95G1UH090CE16	14	12	41000	30000	1400
	E*1P43C+H4TXV02	95G2UH090CE16	14	12	41000	30000	1400
	E*1P49C+H4TXV02	95G1UH090CE16	14	12.2	41000	30000	1355
	E*1P49C+H4TXV02	95G2UH090CE16	14	12.2	41000	30000	1400
	E*1P62C+H4TXV02	95G1UH090CE16	14	12.2	41000	30000	1355
	E*1P62C+H4TXV02	95G2UH090CE16	14	12.2	41000	30000	1400
	EC4X43C	95G1UH090CE16	14	12	41000	30000	1400
	EC4X43C	95G2UH090CE16	14	12	41000	30000	1400
	ED1P48C+H4TXV02	95G2DF090CV20	14	12.2	40000	30000	1450

Note:

1 Certified in accordance with Unitary Air Conditioner Certification Program, which is based on AHRI Standard 210/240

2 Required to achieve AHRI rating. If NA (Not Applicable) is in the piston column, then TXV is required

3 A blower time delay relay is required to achieve AHRI rating. This feature is standard on all Allied Air Enterprises furnace and AH products.

COOLING PERFORMANCE WITH EXTENDED RATINGS

Outdoor Model	Indoor Model	Indoor Temp DB/WB °F	Outdoor Temperature - DB °F														
			65°			82°			95°			105°			115°		
			Btuh	S/T	kW	Btuh	S/T	kW	Btuh	S/T	kW	Btuh	S/T	kW	Btuh	S/T	kW
4AC16L18P	E*1P23	85/72	24,600	0.61	1.24	23,500	0.63	1.47	22,600	0.64	1.65	20,800	0.68	1.85	19,000	0.71	2.04
		80/67	22,700	0.68	1.23	21,300	0.71	1.47	20,300	0.73	1.65	18,800	0.76	1.62	17,400	0.78	2.03
4AC16LR18P		75/63	21,100	0.71	1.22	19,500	0.74	1.44	18,300	0.76	1.62	16,800	0.80	1.82	15,200	0.84	2.02
		75/57	18,721	1.00	1.20	17,800	1.00	1.44	17,000	1.00	1.62	15,700	1.00	1.82	14,400	1.00	2.02
4AC16L24P	E*1P29	85/72	27,700	0.62	1.52	27,400	0.63	1.80	27,200	0.64	2.02	25,700	0.67	2.26	24,200	0.70	2.50
		80/67	26,300	0.69	1.51	25,600	0.71	1.79	25,000	0.73	2.00	23,300	0.77	1.62	20,700	0.80	2.49
4AC16LR24P		75/63	25,500	0.71	1.50	23,900	0.74	1.78	22,600	0.77	1.99	21,000	0.80	2.24	19,500	0.83	2.48
		75/57	23,000	1.00	1.49	21,600	1.00	1.77	20,600	1.00	1.99	19,200	1.00	2.24	17,700	1.00	2.49
4AC16L30P	E*1P29	85/72	32,000	0.59	1.52	30,900	0.63	2.02	30,000	0.66	2.41	28,400	0.70	2.67	26,800	0.74	2.94
		80/67	30,600	0.66	1.80	30,200	0.69	2.17	29,900	0.72	2.45	26,900	0.78	2.68	24,000	0.84	2.91
4AC16LR30P		75/63	29,000	0.73	1.79	27,100	0.77	2.12	25,700	0.80	2.37	23,600	0.84	2.63	21,400	0.88	2.89
		75/57	26,500	1.00	1.79	24,900	1.00	2.13	23,700	1.00	2.38	22,000	1.00	2.64	20,200	1.00	2.89
4AC16L36P	E*1P36B	85/72	41,200	0.62	2.18	39,000	0.64	2.56	37,300	0.66	2.86	35,300	0.69	3.20	33,200	0.71	3.54
		80/67	38,400	0.69	2.16	35,900	0.73	2.56	34,000	0.76	2.86	32,200	0.78	1.62	30,500	0.80	3.55
4AC16LR36P		75/63	36,000	0.71	2.15	33,700	0.74	2.55	32,000	0.77	2.85	30,100	0.80	3.19	28,400	0.82	3.53
		75/57	30,600	1.00	2.14	29,500	1.00	2.54	28,700	1.00	2.85	27,500	1.00	3.18	26,100	1.00	3.51
4AC16L41P	E*1P49C	85/72	46,000	0.75	1.71	43,733	0.77	2.02	42,000	0.79	2.26	39,700	0.82	2.59	37,400	0.84	2.91
		80/67	45,000	0.76	1.70	42,167	0.79	2.01	40,000	0.81	2.25	37,800	0.84	2.58	35,600	0.87	2.90
		75/63	42,500	0.77	1.69	40,233	0.80	2.00	38,500	0.83	2.24	36,650	0.86	2.57	34,800	0.89	2.89
		75/57	40,000	0.79	1.68	38,017	0.82	1.99	36,500	0.84	2.23	35,000	0.88	2.50	33,500	0.91	2.77
4AC16L42P	E*1P49C	85/72	48,500	0.64	2.57	47,300	0.66	3.02	46,300	0.67	3.36	43,800	0.69	3.74	41,300	0.71	4.12
		80/67	46,500	0.70	2.56	44,000	0.73	3.01	42,200	0.75	3.35	39,500	0.78	1.62	36,800	0.81	4.06
4AC16LR42P		75/63	43,700	0.74	2.54	41,000	0.76	2.97	39,000	0.78	3.31	36,000	0.82	3.65	32,800	0.85	4.00
		75/57	39,700	1.00	2.53	37,700	1.00	2.95	36,200	1.00	3.28	33,900	1.00	3.94	31,300	1.00	4.60
4AC16L47P	E*1P62C	85/72	54,000	0.81	2.10	52,583	0.79	2.56	51,500	0.77	2.91	48,750	0.72	3.33	46,000	0.66	3.75
		80/67	53,000	0.82	2.00	50,733	0.80	2.51	49,000	0.79	2.90	46,500	0.81	3.33	44,000	0.83	3.75
		75/63	50,500	0.83	1.99	48,233	0.82	2.50	46,500	0.81	2.89	44,250	0.87	3.30	42,000	0.92	3.71
		75/57	47,000	0.85	1.98	44,733	0.84	2.49	43,000	0.83	2.88	41,500	0.90	3.29	40,000	0.97	3.70
4AC16L48P	E*1P62C	85/72	56,600	0.63	2.99	54,107	0.66	55.36	52,200	0.68	3.88	49,050	0.70	4.29	45,900	0.72	4.70
		80/67	53,100	0.70	2.97	50,607	0.73	3.47	48,700	0.75	3.85	44,500	0.79	4.26	40,300	0.83	4.66
		75/63	50,600	0.72	2.94	46,633	0.76	3.44	43,600	0.79	3.82	39,500	0.84	4.24	35,400	0.88	4.66
		75/57	46,000	1.00	2.92	42,373	1.00	3.43	39,600	1.00	3.82	35,950	1.00	4.24	32,300	1.00	4.65
4AC16L59P	E*1P62C	85/72	61,200	0.63	3.50	60,633	0.64	4.24	60,200	0.65	4.80	58,350	0.68	5.39	56,500	0.70	5.97
		80/67	59,500	0.69	3.50	58,933	0.71	4.21	58,500	0.72	4.75	54,600	0.75	5.34	50,700	0.78	5.93
		75/63	57,800	0.72	3.48	55,760	0.74	4.18	54,200	0.76	4.72	49,850	0.79	5.33	45,500	0.82	5.93
		75/57	53,500	1.00	3.44	51,120	1.00	4.15	49,300	1.00	4.70	44,700	0.92	5.31	40,100	0.83	5.91
4AC16L60P	E*1P62C	85/72	66,300	0.64	4.41	63,600	0.67	4.89	61,600	0.70	5.27	57,900	0.72	5.46	54,200	0.73	5.42
		80/67	62,400	0.66	4.25	59,900	0.71	4.69	58,000	0.74	5.03	54,600	0.75	5.24	51,100	0.75	5.23
		75/63	57,800	0.70	4.03	55,500	0.74	4.50	53,700	0.77	4.87	50,600	0.79	5.06	47,300	0.81	5.04
		75/57	56,200	0.78	4.02	53,900	0.83	4.45	52,200	0.86	4.78	49,100	0.88	4.96	46,000	0.90	4.94

Extended data shown is actual for models listed and typical for all AHRI matches.

ACCESSORIES

Description	Where Used	Kit Number
Crankcase Heater	All models	93M04
Hard Start Kit	18	10J42
	24, 30, 36, 41, 42, 47, 48, 59, 60	88M91
Low Ambient Kit	All models	34M72
Short Cycle Protector	All models	47J27
Freezestat	3/8 tubing	93G35
	5/8 tubing	50A93
Time Delay Relay	All models	58M81
Loss of Charge Kit	All models	84M23 (factory installed)
Sound Blanket	18, 24, 30, 36, 41	14W00 (factory Installed)
	42, 47, 48, 59, 60	14W01 (factory installed)
TXV Kit	18, 24, 30, 36	A4TXV01
	42, 48, 60	A4TXV02

Kit number needs to be the catalog number.

Exception to the above - TXV's, Elect. Heaters can be referred to by the model number.



1-800-448-5872

All specifications and illustrations subject to change without notice and without incurring obligations.