

FORM NO. MGE4-100 (09/2019)

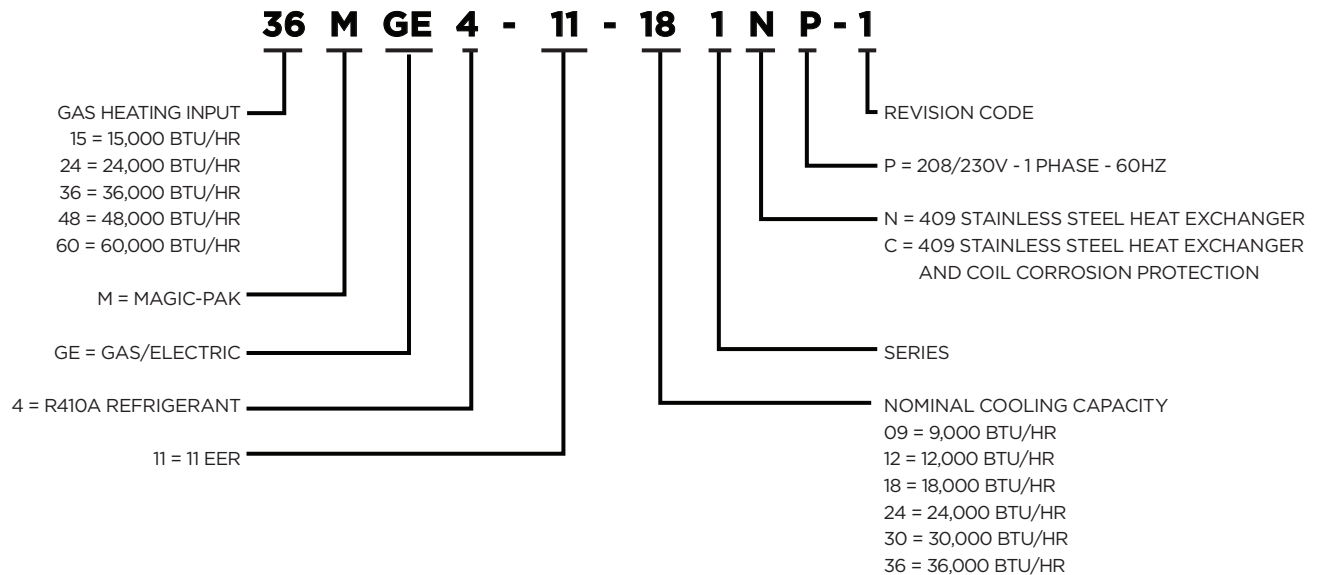

MODEL NUMBER GUIDE



FEATURES AND BENEFITS

WARRANTY

Compressor

Five year limited warranty in all residential and commercial applications.

Heat Exchanger

Twenty year limited warranty on stainless steel heat exchanger in all residential and commercial applications.

All other covered components

Five year limited warranty in all residential and commercial applications.

APPROVALS

Units are design certified by ETL Intertek to latest edition of UL 1995 and ANSI Z21.47.

AHRI Certified to AHRI Standard 390 for Single Packaged Vertical units (SPVAC & SPVHP).

Cooling system rated according to DOE test procedures, and are certified by AHRI.

Heating ratings are according to Department of Energy (DOE) test procedures and Federal Trade Commission (FTC) labeling regulations and are certified by AHRI.

Units are ETL Intertek certified for less than 1.4% cabinet air leakage using ASHRAE Standard 193. Note: Less than 2% on smaller tonnage models.

Gas units are certified as a “direct vent appliance” in accordance to ANSI Z21.47.

Each unit undergoes a full run test operated at the factory before shipment ensuring dependable operation at start-up.

Products using impact resistant louvers are certified to Miami-Dade County standards (TAS 201, TAS 202, and TAS 203) and carry a Notice of Acceptance (N.O.A.) number of 18-0522.03.

Equipment is wind load certified in accordance with the 2017 Florida Building Code wind load calculations up to 186 MPH, risk categories III and IV, and wind exposures C and D.

APPLICATIONS

Designed for installation in conditioned and non-conditioned mechanical spaces within residential and commercial multifamily structures including apartments, condominiums, student and senior housing, and hotels.

Units are approved for installations up to 5,500 ft without any modifications or adjustments. For installations above 5,500 ft, consult the High Altitude Applications table within this specification sheet, or the unit’s installation instructions.

REFRIGERATION SYSTEM

R-410A Refrigerant

Optimized design with 11 EER cooling efficiency. Factory charged with refrigerant. See Specifications table.

Indoor and Outdoor Coils

Copper tube with aluminum fin coils. Available with Climate Guard™ epoxy coated indoor and outdoor coils.

Anti-Microbial Indoor Coil Drain Pan

Anti-Microbial additive resists growth of mold and mildew on drain pan which improves indoor air quality and reduces drain line blockage.

Overflow Protection

Includes an evaporator drain pan overflow switch. Monitors condensate level in drain pan, shuts down unit if drain becomes clogged.

Outdoor Coil Fan

Weather protected heavy duty outdoor coil fan motor with aluminum fan blades for long life. Internally mounted. Totally enclosed weatherproof motor.

High Pressure Switch

Shuts off unit if abnormal operating conditions cause the refrigerant discharge pressure to rise above setting.

Loss of Charge Switch

Provides loss of charge protection by shutting off unit if refrigerant liquid pressure falls below setting.

Secondary Drain Pan

Polypropylene unit base provides redundant overflow protection.

SUPPLY AIR BLOWER

ECM Constant Torque Blower Motor

Electrically efficient motor for reduced electrical consumption. Motor provides specified air volume delivery from 0 through 0.50 in. w.g. duct static range. Blower speed adjustment is easily accomplished by speed tap wiring selection. Motor is resiliently mounted for quiet operation. Blower assembly is easily removed for servicing. See Blower Performance tables.

INDOOR AIR QUALITY**Internal Filter**

Units ship with a 1 in. thick filter from the factory and units have a factory installed 1 in. filter rack. Factory filters are MERV 5 and washable.

CONTROLS**Electronic Blower Control**

Dedicated blower speed taps for continuous fan, cooling, and heating operation are programmed for optimal airflow and controlled by 24V thermostat signals. Fixed blower delays have been selected to enhance comfort.

24 Volt Transformer

40VA transformer furnished and factory installed in control area. Factory wired for 230V applications, optional terminal for 208V applications.

Inducer Cycling

Pests are discouraged from nesting in the unit's flue pipe during summer months by briefly energizing the gas furnace inducer fan at the beginning of each cooling cycle.

CABINET

Conditioned areas insulated with foil faced 0.5 in. insulation to minimize heat loss and reduce operating sound levels. Polystyrene insulation in outdoor section of cabinet is weather resistant and provides reduced sound levels.

Embossed steel cabinet for maximum durability.
Easy forward-facing service access.
Pre-bent duct flange connections.
Tool-less filter access.

Electrical Inlets and Service Valves

Field wiring inlets are located on the top of the cabinet. See Dimension drawing.
Gauge ports located inside compressor service compartment of the cabinet.

OTHER ACCESSORIES**Wall Sleeves**

Required for all installations. Wall sleeves penetrate the building envelope and create a path for condenser air intake and exhaust, as well as flue gas exhaust on gas heating models. The wall sleeve completes the building envelope by creating a seal to the equipment and provides a secure attachment foundation for external louvers. Wall sleeves are available in a minimum depth of 6 in. and a maximum depth of 12 in.

Wall sleeve bases are polypropylene and specifically designed to act as a drain pan to direct rain water out of the building as well as handle any overflow from condensation generated by the condensing section of the system (in the event of a clogged primary drain). Larger height wall sleeves may be used on smaller tonnage equipment to maintain a consistent louver size on the building's façade. Refer to the application guide and wall sleeve installation instructions.

Architectural Aluminum Louver

Louvers are required for all installations. Aluminum louvers offer a more robust grill on the building's façade and a wider range of standard colors. Louvers are painted with 70% flouropolymer and meets AAMA 2605 specifications, and carry a 20 year paint warranty*. Custom color matching is also available. 6063-T6 grade aluminum is used.

See application guide for details.

Architectural Polypropylene Louver (3/4 thru 2 1/2 ton)

Louvers are required for all installations. Polypropylene louvers are constructed from durable, corrosion resistant plastic and are available in four colors to compliment any architectural design.

Impact Resistant Aluminum Louver

Impact resistant aluminum louvers offer the most protection for a structure and used for areas that will experience extreme winds. Certified to Miami-Dade County building standards, the louvers are ideal for hurricane prone areas. Impact louvers are available in a wide range of standard colors. Louvers are painted with 70% flouropolymer and meets AAMA 2605 specifications, and carry a 20 year paint warranty*. Custom color matching is also available. 6063-T6 grade aluminum is used. Miami-Dade NOA# 18-0522.03.

See application guide for details.

LP Conversion Kit

Available field installed accessory kit supports simple conversion for LP gas installations.

* Certain exclusions apply. Refer to louver manufacture's warranty documentation.

ELECTRICAL AND PHYSICAL DATA (208/230V - 1 PHASE - 60HZ) ¹

Model	Minimum Circuit Ampacity	MOCP ²	Compressor		Outside Fan				Indoor Blower			R410A Refrig. Charge (oz.)	Approx. Shipping Weight (lbs.)
			Rated Load Amps	Locked Rotor Amps	Dia. (in.)	Nominal RPM	Rated Load Amps	Rated HP	Wheel D x W (in.)	Rated Load Amps	Rated HP		
15MGE4-11-091*P 24MGE4-11-091*P	6.4	15	3.5	21.0	18	1050	0.9	1/8	10 x 6	2.8	1/3	40	238
15MGE4-11-121*P 24MGE4-11-121*P 36MGE4-11-121*P	7.6	15	5.0	27.0	18	1025	0.9	1/8	10 x 6	2.8	1/3	63	273
15MGE4-11-181*P 24MGE4-11-181*P 36MGE4-11-181*P 48MGE4-11-181*P 60MGE4-11-181*P	10.7	15	6.5	37.5	18	1025	0.9	1/8	10 x 6	2.8	1/3	68	276
15MGE4-11-241*P 24MGE4-11-241*P 36MGE4-11-241*P 48MGE4-11-241*P 60MGE4-11-241*P	13.2	20	8.4	38.0	18	1050	0.9	1/8	10 x 6	2.8	1/3	75	301
24MGE4-11-301*P 36MGE4-11-301*P 48MGE4-11-301*P 60MGE4-11-301*P	21.8	35	15.0	72.5	18	1200	2.8	1/3	10 x 6	4.1	1/2	82	319
24MGE4-11-361*P 36MGE4-11-361*P 48MGE4-11-361*P 60MGE4-11-361*P	23.9	35	14.7	75.0	18	1,200	2.8	1/3	10 x 7	4.1	1/2	96	349

1. Acceptable voltage range: 197 -253 V

2. MOCP = Maximum Over Current Protection

PERFORMANCE

Model	Gas Heating				Cooling				
	Input (Btu/hr)	Output (Btu/hr)	Rise Range (F°)	Thermal Efficiency (%)	Capacity (Btu/hr)	EER	S/T	CFM	Outdoor Sound Rating (dba) ¹
15MGE4-11-091*P	15,000	12,000	15 - 45	80	8,600	11.0	0.77	350	75
24MGE4-11-091*P	24,000	19,200	25 - 55						
15MGE4-11-121*P	15,000	12,000	15 - 45	80	12,000	11.2	0.70	400	75
24MGE4-11-121*P	24,000	19,200	25 - 55						
36MGE4-11-121*P	36,000	28,800	30 - 60						
15MGE4-11-181*P	15,000	12,000	15 - 45	80	17,200	11.2	0.77	650	75
24MGE4-11-181*P	24,000	19,200	25 - 55						
36MGE4-11-181*P	36,000	28,800	30 - 60						
48MGE4-11-181*P	48,000	38,400	35 - 65						
60MGE4-11-181*P	60,000	48,000	40 - 70						
15MGE4-11-241*P	15,000	12,000	15 - 45	80	22,600	11.2	0.77	800	76
24MGE4-11-241*P	24,000	19,200	25 - 55						
36MGE4-11-241*P	36,000	28,800	30 - 60						
48MGE4-11-241*P	48,000	38,400	35 - 65						
60MGE4-11-241*P	60,000	48,000	40 - 70						
24MGE4-11-301*P	24,000	19,200	25 - 55	80	28,200	11.0	0.73	900	81
36MGE4-11-301*P	36,000	28,800	30 - 60						
48MGE4-11-301*P	48,000	38,400	35 - 65						
60MGE4-11-301*P	60,000	48,000	40 - 70						
24MGE4-11-361*P	24,000	19,200	25 - 55	80	34,200	11.0	0.72	1,000	77
36MGE4-11-361*P	36,000	28,800	30 - 60						
48MGE4-11-361*P	48,000	38,400	35 - 65						
60MGE4-11-361*P	60,000	48,000	40 - 70						

1. Per ANSI/AHRI Standard 720

BLOWER PERFORMANCE (208 OR 230V)

3/4 Ton	Model	Gas Heating		Indoor Blower Speed	0.1" w.c.				0.2" w.c.				0.3" w.c.				0.4" w.c.				0.5" w.c.				
		Rise Range (F°)	Mid Rise (F°)		SCFM	Watts	HP	Temp Rise	SCFM	Watts	HP	Temp Rise	SCFM	Watts	HP	Temp Rise	SCFM	Watts	HP	Temp Rise	SCFM	Watts	HP	Temp Rise	
3/4 Ton	15MGE4-11-091*P	15 - 45	30	TAP 1 (FAN)	430	46	0.06	---	370	50	0.07	---	320	53	0.07	---	265	57	0.08	---	200	62	0.08	---	
				TAP 2 (COOL)†	375	39	0.05	---	315	42	0.06	---	N/A	N/A	N/A	---	N/A	N/A	N/A	---	N/A	N/A	N/A	---	
				TAP 3 (COOL)	N/A	N/A	N/A	---	N/A	N/A	N/A	---	440	83	0.11	---	390	87	0.12	---	340	92	0.12	---	
				TAP 4 (HEAT)*	365	35	0.05	31	300	39	0.05	37	240	42	0.06	47	N/A	N/A	N/A	N/A	N/A	N/A	N/A	N/A	N/A
				TAP 5 (HEAT)	N/A	N/A	N/A	N/A	N/A	N/A	N/A	N/A	460	83	0.11	24	415	88	0.12	27	370	98	0.13	30	
	24MGE4-11-091*P	25 - 55	40	TAP 1 (FAN)	430	46	0.06	---	370	50	0.07	---	320	53	0.07	---	265	57	0.08	---	200	62	0.08	---	
				TAP 2 (COOL)†	375	39	0.05	---	315	42	0.06	---	N/A	N/A	N/A	---	N/A	N/A	N/A	---	N/A	N/A	N/A	---	
				TAP 3 (COOL)	N/A	N/A	N/A	---	N/A	N/A	N/A	---	440	83	0.11	---	390	87	0.12	---	340	92	0.12	---	
				TAP 4 (HEAT)*	445	48	0.06	40	390	53	0.07	46	340	56	0.08	53	N/A	N/A	N/A	N/A	N/A	N/A	N/A	N/A	
				TAP 5 (HEAT)	N/A	N/A	N/A	N/A	N/A	N/A	N/A	N/A	530	102	0.14	34	480	108	0.14	37	440	114	0.15	41	

1 Ton	15MGE4-11-121*P	15 - 45	30	TAP 1 (FAN)	415	39	0.05	---	350	43	0.06	---	285	47	0.06	---	240	51	0.07	---	165	54	0.07	---
				TAP 2 (COOL)†	425	46	0.06	---	370	49	0.07	---	315	53	0.07	---	N/A	N/A	N/A	---	N/A	N/A	N/A	---
				TAP 3 (COOL)	N/A	N/A	N/A	---	N/A	N/A	N/A	---	475	93	0.12	---	430	97	0.13	---	385	101	0.14	---
				TAP 4 (HEAT)*	370	36	0.05	30	315	39	0.05	35	260	42	0.06	43	N/A	N/A	N/A	N/A	N/A	N/A	N/A	N/A
				TAP 5 (HEAT)	N/A	N/A	N/A	N/A	N/A	N/A	N/A	N/A	470	80	0.11	24	415	85	0.11	27	370	89	0.12	30
	24MGE4-11-121*P	25 - 55	40	TAP 1 (FAN)	415	39	0.05	---	350	43	0.06	---	285	47	0.06	---	240	51	0.07	---	165	54	0.07	---
				TAP 2 (COOL)†	425	46	0.06	---	370	49	0.07	---	315	53	0.07	---	N/A	N/A	N/A	---	N/A	N/A	N/A	---
				TAP 3 (COOL)	N/A	N/A	N/A	---	N/A	N/A	N/A	---	475	93	0.12	---	430	97	0.13	---	385	101	0.14	---
				TAP 4 (HEAT)*	450	50	0.07	40	405	53	0.07	44	355	57	0.08	50	N/A	N/A	N/A	N/A	N/A	N/A	N/A	N/A
				TAP 5 (HEAT)	N/A	N/A	N/A	N/A	N/A	N/A	N/A	N/A	525	101	0.14	34	485	105	0.14	37	450	110	0.15	40
	36MGE4-11-121*P	30 - 60	45	TAP 1 (FAN)	415	39	0.05	---	350	43	0.06	---	285	47	0.06	---	240	51	0.07	---	165	54	0.07	---
				TAP 2 (COOL)†	425	46	0.06	---	370	49	0.07	---	315	53	0.07	---	N/A	N/A	N/A	---	N/A	N/A	N/A	---
				TAP 3 (COOL)	N/A	N/A	N/A	---	N/A	N/A	N/A	---	475	93	0.12	---	430	97	0.13	---	385	101	0.14	---
				TAP 4 (HEAT)*	590	87	0.12	45	555	91	0.12	48	515	96	0.13	52	475	100	0.134	56	N/A	N/A	N/A	N/A
				TAP 5 (HEAT)	N/A	N/A	N/A	N/A	680	138	0.19	39	650	143	0.19	41	615	148	0.198	44	585	153	0.21	46

N/A: Do not operate unit using this blower speed at this external static pressure.

† As shipped speed for Cooling operation. Blower speed must be field adjusted to speed Tap 3 for higher duct static applications.

* As shipped speed for Heating operation. Blower speed must be field adjusted to speed Tap 5 for higher duct static applications.

BLOWER PERFORMANCE (208 OR 230V)

	Model	Gas Heating		Indoor Blower Speed	0.1" w.c.				0.2" w.c.				0.3" w.c.				0.4" w.c.				0.5" w.c.				
		Rise Range (F°)	Mid Rise (F°)		SCFM	Watts	HP	Temp Rise	SCFM	Watts	HP	Temp Rise	SCFM	Watts	HP	Temp Rise	SCFM	Watts	HP	Temp Rise	SCFM	Watts	HP	Temp Rise	
1.5 Ton	15MGE4-11-181P-P	15-45	30	TAP 1 (FAN)	470	54	0.07	---	400	59	0.08	---	345	63	0.08	---	290	67	0.09	---	235	70	0.09	---	
				TAP 2 (COOL)*	670	118	0.16	---	625	123	0.16	---	565	131	0.18	---	525	136	0.18	---	N/A	N/A	N/A	---	
				TAP 3 (COOL)	N/A	N/A	N/A	---	765	184	0.25	---	730	191	0.26	---	675	201	0.27	---	630	206	0.28	---	
				TAP 4 (HEAT)*	370	39	0.05	30	305	43	0.06	37	250	46	0.06	45	N/A	N/A	N/A	N/A	N/A	N/A	N/A	N/A	N/A
				TAP 5 (HEAT)	N/A	N/A	N/A	N/A	N/A	N/A	N/A	N/A	460	92	0.12	24	415	96	0.13	27	370	101	0.14	30	
	24MGE4-11-181P-P	25-55	40	TAP 1 (FAN)	470	54	0.07	---	400	59	0.08	---	345	63	0.08	---	290	67	0.09	---	235	70	0.09	---	
				TAP 2 (COOL)*	670	118	0.16	---	625	123	0.16	---	565	131	0.18	---	525	136	0.18	---	N/A	N/A	N/A	---	
				TAP 3 (COOL)	N/A	N/A	N/A	---	765	184	0.25	---	730	191	0.26	---	675	201	0.27	---	630	206	0.28	---	
				TAP 4 (HEAT)*	450	52	0.07	40	385	57	0.08	46	330	61	0.08	54	N/A	N/A	N/A	N/A	N/A	N/A	N/A	N/A	
				TAP 5 (HEAT)	N/A	N/A	N/A	N/A	N/A	N/A	N/A	N/A	540	116	0.16	33	490	121	0.16	37	450	127	0.17	40	
	36MGE4-11-181P-P	30-60	45	TAP 1 (FAN)	470	54	0.07	---	400	59	0.08	---	345	63	0.08	---	290	67	0.09	---	235	70	0.09	---	
				TAP 2 (COOL)*	670	118	0.16	---	625	123	0.16	---	565	131	0.18	---	525	136	0.18	---	N/A	N/A	N/A	---	
				TAP 3 (COOL)	N/A	N/A	N/A	---	765	184	0.25	---	730	191	0.26	---	675	201	0.27	---	630	206	0.28	---	
				TAP 4 (HEAT)*	590	86	0.12	45	555	90	0.12	48	515	95	0.13	52	475	99	0.13	56	N/A	N/A	N/A	N/A	
				TAP 5 (HEAT)	715	129	0.17	38	680	135	0.18	39	650	140	0.19	41	615	146	0.20	44	585	151	0.20	46	
	48MGE4-11-181P-P	35-65	50	TAP 1 (FAN)	470	54	0.07	---	400	59	0.08	---	345	63	0.08	---	290	67	0.09	---	235	70	0.09	---	
				TAP 2 (COOL)*	670	118	0.16	---	625	123	0.16	---	565	131	0.18	---	525	136	0.18	---	N/A	N/A	N/A	---	
				TAP 3 (COOL)	N/A	N/A	N/A	---	765	184	0.25	---	730	191	0.26	---	675	201	0.27	---	630	206	0.28	---	
				TAP 4 (HEAT)*	695	141	0.19	51	655	147	0.20	54	620	153	0.21	58	580	161	0.22	62	N/A	N/A	N/A	N/A	
				TAP 5 (HEAT)	830	214	0.29	43	795	221	0.30	45	760	228	0.31	47	730	236	0.32	49	690	242	0.32	52	
60MGE4-11-181P-P	40-70	55	TAP 1 (FAN)	470	54	0.07	---	400	59	0.08	---	345	63	0.08	---	290	67	0.09	---	235	70	0.09	---		
			TAP 2 (COOL)*	670	118	0.16	---	625	123	0.16	---	565	131	0.18	---	525	136	0.18	---	N/A	N/A	N/A	---		
			TAP 3 (COOL)	N/A	N/A	N/A	---	765	184	0.25	---	730	191	0.26	---	675	201	0.27	---	630	206	0.28	---		
			TAP 4 (HEAT)*	800	182	0.24	56	770	187	0.25	58	740	191	0.26	60	710	198	0.27	63	675	204	0.27	66		
			TAP 5 (HEAT)	905	250	0.34	49	870	257	0.34	51	850	263	0.35	53	825	270	0.36	54	805	276	0.37	56		

N/A: Do not operate unit using this blower speed at this external static pressure.

* As shipped speed for Cooling operation. Blower speed must be field adjusted to speed Tap 3 for higher duct static applications.

* As shipped speed for Heating operation. Blower speed must be field adjusted to speed Tap 5 for higher duct static applications.

BLOWER PERFORMANCE (208 OR 230V)

Model	Gas Heating		Indoor Blower Speed	0.1" w.c.				0.2" w.c.				0.3" w.c.				0.4" w.c.				0.5" w.c.						
	Rise Range (F°)	Mid Rise (F°)		SCFM	Watts	HP	Temp Rise	SCFM	Watts	HP	Temp Rise	SCFM	Watts	HP	Temp Rise	SCFM	Watts	HP	Temp Rise	SCFM	Watts	HP	Temp Rise			
	2 Ton	15MGE4-11-241*P		15-45	30	TAP 1 (FAN)	450	49	0.07	---	400	52	0.07	---	345	56	0.08	---	285	59	0.08	---	235	65	0.09	---
TAP 2 (COOL)*			815			206	0.28	---	780	210	0.28	---	750	215	0.29	---	720	219	0.29	---	690	224	0.30	---		
TAP 3 (COOL)			910			273	0.37	---	880	278	0.37	---	850	283	0.38	---	820	287	0.38	---	785	286	0.38	---		
TAP 4 (HEAT)*			370			36	0.05	30	320	38	0.05	35	250	42	0.06	45	N/A	N/A	N/A	N/A	N/A	N/A	N/A	N/A	N/A	N/A
TAP 5 (HEAT)			N/A			N/A	N/A	N/A	N/A	N/A	N/A	N/A	465	82	0.110	24	420	85	0.11	26	370	90	0.12	30		
24MGE4-11-241*P		25-55	40	TAP 1 (FAN)	450	49	0.07	---	400	52	0.07	---	345	56	0.08	---	285	59	0.08	---	235	65	0.09	---		
				TAP 2 (COOL)*	815	206	0.28	---	780	210	0.28	---	750	215	0.29	---	720	219	0.29	---	690	224	0.30	---		
				TAP 3 (COOL)	910	273	0.37	---	880	278	0.37	---	850	283	0.38	---	820	287	0.38	---	785	286	0.38	---		
				TAP 4 (HEAT)*	450	49	0.07	40	400	52	0.07	45	345	56	0.08	52	N/A	N/A	N/A	N/A	N/A	N/A	N/A	N/A	N/A	
				TAP 5 (HEAT)	N/A	N/A	N/A	N/A	N/A	N/A	N/A	N/A	530	99	0.13	34	490	103	0.14	37	450	107	0.14	40		
36MGE4-11-241*P		30-60	45	TAP 1 (FAN)	450	49	0.07	---	400	52	0.07	---	345	56	0.08	---	285	59	0.08	---	235	65	0.09	---		
				TAP 2 (COOL)*	815	206	0.28	---	780	210	0.28	---	750	215	0.29	---	720	219	0.29	---	690	224	0.30	---		
				TAP 3 (COOL)	910	273	0.37	---	880	278	0.37	---	850	283	0.38	---	820	287	0.38	---	785	286	0.38	---		
				TAP 4 (HEAT)*	600	89	0.12	45	560	93	0.12	48	520	96	0.13	52	485	100	0.13	56	N/A	N/A	N/A	N/A		
				TAP 5 (HEAT)	N/A	N/A	N/A	N/A	700	148	0.20	38	665	153	0.21	40	635	157	0.21	42	600	162	0.22	45		
48MGE4-11-241*P		35-65	50	TAP 1 (FAN)	450	49	0.07	---	400	52	0.07	---	345	56	0.08	---	285	59	0.08	---	235	65	0.09	---		
				TAP 2 (COOL)*	815	206	0.28	---	780	210	0.28	---	750	215	0.29	---	720	219	0.29	---	690	224	0.30	---		
				TAP 3 (COOL)	910	273	0.37	---	880	278	0.37	---	850	283	0.38	---	820	287	0.38	---	785	286	0.38	---		
				TAP 4 (HEAT)*	720	145	0.19	50	675	151	0.20	53	635	157	0.21	56	595	164	0.22	60	N/A	N/A	N/A	N/A		
				TAP 5 (HEAT)	N/A	N/A	N/A	N/A	820	223	0.30	44	780	232	0.31	46	745	238	0.32	48	710	246	0.33	50		
60MGE4-11-241*P	40-70	55	TAP 1 (FAN)	450	49	0.07	---	400	52	0.07	---	345	56	0.08	---	285	59	0.08	---	235	65	0.09	---			
			TAP 2 (COOL)*	815	206	0.28	---	780	210	0.28	---	750	215	0.29	---	720	219	0.29	---	690	224	0.30	---			
			TAP 3 (COOL)	910	273	0.37	---	880	278	0.37	---	850	283	0.38	---	820	287	0.38	---	785	286	0.38	---			
			TAP 4 (HEAT)*	810	182	0.24	55	775	186	0.25	58	745	191	0.26	60	710	195	0.26	63	680	200	0.27	66			
			TAP 5 (HEAT)	910	248	0.33	49	885	253	0.34	51	860	258	0.35	52	830	265	0.36	54	800	270	0.36	56			

N/A: Do not operate unit using this blower speed at this external static pressure.

* As shipped speed for Cooling operation. Blower speed must be field adjusted to speed Tap 3 for higher duct static applications.

* As shipped speed for Heating operation. Blower speed must be field adjusted to speed Tap 5 for higher duct static applications.

BLOWER PERFORMANCE (208 OR 230V)

2.5 Ton	Model	Gas Heating		Indoor Blower Speed	0.1" w.c.				0.2" w.c.				0.3" w.c.				0.4" w.c.				0.5" w.c.					
		Rise Range (F°)	Mid Rise (F°)		SCFM	Watts	HP	Temp Rise	SCFM	Watts	HP	Temp Rise	SCFM	Watts	HP	Temp Rise	SCFM	Watts	HP	Temp Rise	SCFM	Watts	HP	Temp Rise		
	24MGE4-11-301P	25-55	40	TAP 1 (FAN)	490	55	0.07	---	465	65	0.09	---	435	72	0.10	---	415	81	0.11	---	390	89	0.12	---		
				TAP 2 (COOL) [†]	930	239	0.32	---	900	243	0.33	---	885	250	0.34	---	835	256	0.34	---	805	262	0.35	---		
				TAP 3 (COOL)	1030	309	0.41	---	995	316	0.42	---	965	321	0.43	---	930	325	0.44	---	900	328	0.44	---		
				TAP 4 (HEAT) [*]	450	47	0.06	40	400	49	0.07	45	350	53	0.07	51	N/A	N/A	N/A	N/A	N/A	N/A	N/A	N/A	N/A	N/A
				TAP 5 (HEAT)	N/A	N/A	N/A	N/A	N/A	N/A	N/A	N/A	530	93	0.12	34	490	98	0.13	37	450	103	0.14	40		
	36MGE4-11-301P	30-60	45	TAP 1 (FAN)	490	55	0.07	---	465	65	0.09	---	435	72	0.10	---	415	81	0.11	---	390	89	0.12	---		
				TAP 2 (COOL) [†]	930	239	0.32	---	900	243	0.33	---	885	250	0.34	---	835	256	0.34	---	805	262	0.35	---		
				TAP 3 (COOL)	1030	309	0.41	---	995	316	0.42	---	965	321	0.43	---	930	325	0.44	---	900	328	0.44	---		
				TAP 4 (HEAT) [*]	600	80	0.11	45	560	84	0.11	48	515	89	0.12	52	475	93	0.12	56	N/A	N/A	N/A	N/A		
				TAP 5 (HEAT)	N/A	N/A	N/A	N/A	705	136	0.18	38	670	141	0.19	40	635	146	0.20	42	600	151	0.20	45		
	48MGE4-11-301P	35-65	50	TAP 1 (FAN)	490	55	0.07	---	465	65	0.09	---	435	72	0.10	---	415	81	0.11	---	390	89	0.12	---		
				TAP 2 (COOL) [†]	930	239	0.32	---	900	243	0.33	---	885	250	0.34	---	835	256	0.34	---	805	262	0.35	---		
				TAP 3 (COOL)	1030	309	0.41	---	995	316	0.42	---	965	321	0.43	---	930	325	0.44	---	900	328	0.44	---		
				TAP 4 (HEAT) [*]	715	140	0.19	50	670	146	0.20	53	630	152	0.20	57	590	159	0.21	61	N/A	N/A	N/A	N/A		
				TAP 5 (HEAT)	N/A	N/A	N/A	N/A	815	218	0.30	44	775	227	0.30	46	740	233	0.31	48	705	241	0.32	51		
	60MGE4-11-301P	40-70	55	TAP 1 (FAN)	490	55	0.07	---	465	65	0.09	---	435	72	0.10	---	415	81	0.11	---	390	89	0.12	---		
				TAP 2 (COOL) [†]	930	239	0.32	---	900	243	0.33	---	885	250	0.34	---	835	256	0.34	---	805	262	0.35	---		
				TAP 3 (COOL)	1030	309	0.41	---	995	316	0.42	---	965	321	0.43	---	930	325	0.44	---	900	328	0.44	---		
				TAP 4 (HEAT) [*]	810	163	0.22	55	775	169	0.23	58	740	173	0.23	60	710	179	0.24	63	680	185	0.25	66		
				TAP 5 (HEAT)	935	233	0.31	48	900	240	0.32	50	870	245	0.33	52	835	254	0.34	53	810	257	0.34	55		

N/A: Do not operate unit using this blower speed at this external static pressure.
[†] As shipped speed for Cooling operation. Blower speed must be field adjusted to speed Tap 3 for higher duct static applications.
^{*} As shipped speed for Heating operation. Blower speed must be field adjusted to speed Tap 5 for higher duct static applications.

BLOWER PERFORMANCE (208 OR 230V)

3 Ton	Model	Gas Heating		Indoor Blower Speed	0.1" w.c.				0.2" w.c.				0.3" w.c.				0.4" w.c.				0.5" w.c.					
		Rise Range (F°)	Mid Rise (F°)		SCFM	Watts	HP	Temp Rise	SCFM	Watts	HP	Temp Rise	SCFM	Watts	HP	Temp Rise	SCFM	Watts	HP	Temp Rise	SCFM	Watts	HP	Temp Rise		
3 Ton	24MGE4-11-361*P	25-55	40	TAP 1 (FAN)	615	82	0.11	---	580	86	0.12	---	540	91	0.12	---	500	96	0.13	---	450	102	0.14	---		
				TAP 2 (COOL) [†]	1020	307	0.41	---	980	313	0.42	---	940	314	0.42	---	900	318	0.43	---	865	323	0.43	---		
				TAP 3 (COOL)	1040	329	0.44	---	1000	329	0.44	---	965	333	0.45	---	930	338	0.45	---	890	344	0.46	---		
				TAP 4 (HEAT) [*]	450	48	0.06	40	385	52	0.07	46	325	55	0.07	55	N/A	N/A	N/A	N/A	N/A	N/A	N/A	N/A	N/A	N/A
				TAP 5 (HEAT)	N/A	N/A	N/A	N/A	N/A	N/A	N/A	N/A	550	107	0.14	33	500	112	0.15	36	450	117	0.16	40		
	36MGE4-11-361*P	30-60	45	TAP 1 (FAN)	615	82	0.11	---	580	86	0.12	---	540	91	0.12	---	500	96	0.13	---	450	102	0.14	---		
				TAP 2 (COOL) [†]	1020	307	0.41	---	980	313	0.42	---	940	314	0.42	---	900	318	0.43	---	865	323	0.43	---		
				TAP 3 (COOL)	1040	329	0.44	---	1000	329	0.44	---	965	333	0.45	---	930	338	0.45	---	890	344	0.46	---		
				TAP 4 (HEAT) [*]	615	82	0.11	44	580	86	0.12	46	540	91	0.12	50	500	96	0.13	54	460	102	0.14	58		
				TAP 5 (HEAT)	N/A	N/A	N/A	N/A	710	129	0.17	38	685	135	0.18	39	650	140	0.19	41	615	145	0.19	44		
	48MGE4-11-361*P	35-65	50	TAP 1 (FAN)	615	82	0.11	---	580	86	0.12	---	540	91	0.12	---	500	96	0.13	---	450	102	0.14	---		
				TAP 2 (COOL) [†]	1020	307	0.41	---	980	313	0.42	---	940	314	0.42	---	900	318	0.43	---	865	323	0.43	---		
				TAP 3 (COOL)	1040	329	0.44	---	1000	329	0.44	---	965	333	0.45	---	930	338	0.45	---	890	344	0.46	---		
				TAP 4 (HEAT) [*]	715	135	0.18	50	675	142	0.19	53	640	148	0.20	56	600	155	0.21	60	560	162	0.22	64		
				TAP 5 (HEAT)	N/A	N/A	N/A	N/A	820	212	0.28	44	785	219	0.29	46	745	227	0.30	48	715	234	0.31	50		
	60MGE4-11-361*P	40-70	55	TAP 1 (FAN)	615	82	0.11	---	580	86	0.12	---	540	91	0.12	---	500	96	0.13	---	450	102	0.14	---		
				TAP 2 (COOL) [†]	1020	307	0.41	---	980	313	0.42	---	940	314	0.42	---	900	318	0.43	---	865	323	0.43	---		
				TAP 3 (COOL)	1040	329	0.44	---	1000	329	0.44	---	965	333	0.45	---	930	338	0.45	---	890	344	0.46	---		
				TAP 4 (HEAT) [*]	825	175	0.23	54	790	179	0.24	57	755	185	0.25	59	720	191	0.26	62	690	197	0.26	65		
				TAP 5 (HEAT)	935	240	0.32	48	905	246	0.33	49	870	254	0.34	51	845	260	0.35	53	815	266	0.36	55		

N/A: Do not operate unit using this blower speed at this external static pressure.

[†] As shipped speed for Cooling operation. Blower speed must be field adjusted to speed Tap 3 for higher duct static applications.

^{*} As shipped speed for Heating operation. Blower speed must be field adjusted to speed Tap 5 for higher duct static applications.

COOLING PERFORMANCE EXTENDED RATINGS

Model	Indoor Temp DB/WB (°F)	Outdoor Temperature - DB (°F)														
		65			85			95			105			115		
		Btu/Hr	S/T	kW	Btu/Hr	S/T	kW	Btu/Hr	S/T	kW	Btu/Hr	S/T	kW	Btu/Hr	S/T	kW
*MGE4-11-091P	85/72	10,400	0.61	0.62	9,600	0.65	0.73	9,200	0.67	0.78	8,600	0.71	0.85	8,000	0.74	0.91
	80/67	9,600	0.69	0.62	8,900	0.74	0.73	8,600	0.77	0.78	8,000	0.81	0.85	7,400	0.85	0.91
	75/63	9,000	0.71	0.63	8,300	0.77	0.73	8,000	0.80	0.78	7,400	0.86	0.84	6,700	0.92	0.91
	75/57	8,100	1.00	0.63	7,800	1.00	0.73	7,700	1.00	0.78	7,100	1.00	0.84	6,500	1.00	0.91
*MGE4-11-121P	85/72	14,300	0.58	0.83	13,800	0.60	0.99	13,500	0.61	1.07	12,600	0.64	1.17	11,600	0.67	1.28
	80/67	13,500	0.64	0.84	12,500	0.68	0.99	12,000	0.70	1.07	11,300	0.73	1.17	10,600	0.76	1.27
	75/63	12,900	0.68	0.83	12,200	0.72	0.99	11,800	0.74	1.07	10,700	0.77	1.17	9,600	0.80	1.27
	75/57	11,000	1.00	0.84	10,600	1.00	0.99	10,400	1.00	1.07	9,600	1.00	1.16	8,800	1.00	1.26
*MGE4-11-181P	85/72	20,100	0.62	1.18	19,000	0.66	1.41	18,500	0.68	1.52	17,100	0.73	1.65	15,800	0.77	1.79
	80/67	19,500	0.69	1.18	18,000	0.74	1.41	17,200	0.77	1.52	15,700	0.83	1.65	14,200	0.88	1.78
	75/63	18,700	0.73	1.19	17,000	0.79	1.41	16,200	0.82	1.52	14,600	0.87	1.64	13,000	0.92	1.77
	75/57	17,300	1.00	1.19	14,100	1.00	1.41	12,500	1.00	1.52	12,500	1.00	1.64	12,500	1.00	1.77
*MGE4-11-241P	85/72	26,100	0.61	1.55	25,100	0.66	1.88	24,500	0.68	2.05	22,900	0.72	2.24	21,200	0.75	2.44
	80/67	25,000	0.68	1.54	23,400	0.74	1.86	22,600	0.77	2.02	20,900	0.82	2.22	19,200	0.87	2.42
	75/63	24,100	0.71	1.54	22,400	0.78	1.86	21,500	0.81	2.02	19,500	0.86	2.20	17,500	0.91	2.39
	75/57	23,200	1.00	1.52	21,300	1.00	1.84	20,400	1.00	2.00	18,900	1.00	2.02	17,300	1.00	2.04
*MGE4-11-301P	85/72	27,000	0.63	1.96	28,800	0.65	2.38	29,800	0.66	2.58	28,300	0.68	2.87	26,900	0.70	3.15
	80/67	30,300	0.68	1.95	28,900	0.71	2.36	28,200	0.73	2.56	26,700	0.76	2.84	25,200	0.79	3.12
	75/63	29,100	0.71	1.94	27,700	0.74	2.35	26,900	0.76	2.55	25,300	0.80	2.82	23,600	0.83	3.08
	75/57	26,300	1.00	1.93	25,600	1.00	2.33	25,300	1.00	2.53	23,700	1.00	2.80	22,100	1.00	3.08
*MGE4-11-361P	85/72	38,400	0.63	2.37	37,200	0.64	2.89	36,600	0.65	3.15	34,900	0.67	3.50	33,200	0.68	3.85
	80/67	36,400	0.68	2.35	34,900	0.71	2.86	34,200	0.72	3.11	32,600	0.74	3.46	31,000	0.76	3.81
	75/63	35,300	0.71	2.34	33,700	0.73	2.85	32,900	0.74	3.11	30,700	0.77	3.44	28,600	0.79	3.78
	75/57	30,900	1.00	2.33	30,100	1.00	2.82	29,600	1.00	3.07	27,900	1.00	3.10	26,200	1.00	3.12

ACCESSORIES DIMENSIONS (IN.)

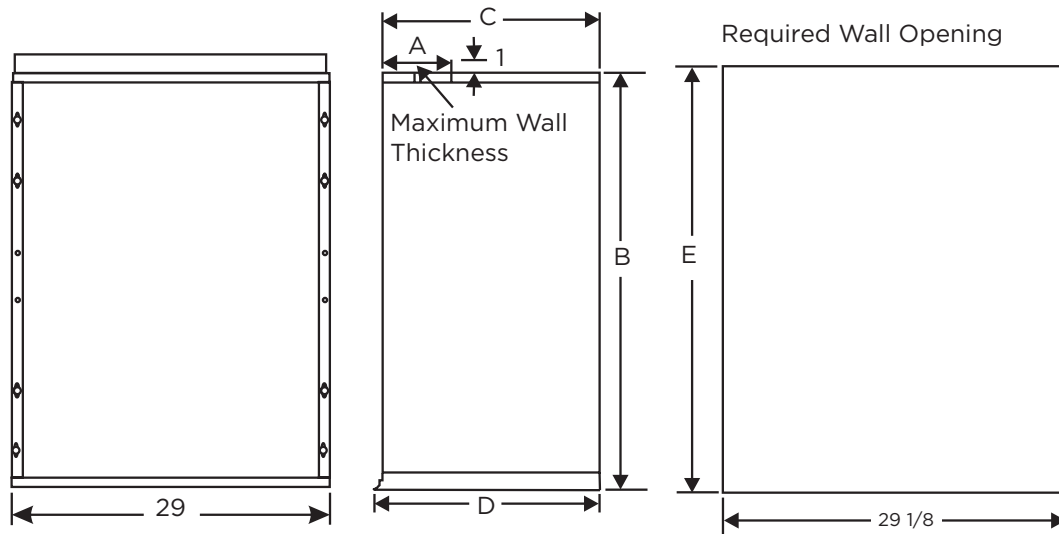

ACCESSORIES

Accessory		Nomenclature	Magic-Pak Unit						Dimensions (in.)				
			**MGE4-11-091*P	**MGE4-11-121*P	**MGE4-11-181*P	**MGE4-11-241*P	**MGE4-11-301*P	**MGE4-11-361*P	A	B	C	D	E
6" Wall Sleeve Kit	for 29" Louver	ASLEEVE6-1	•	•	•	•		6	29	16	16-5/8	29-1/8	
	for 33" Louver	ASLEEVE6-2	•	•	•	•	•	6	32-3/4	16	16-5/8	32-7/8	
	for 45" Louver	ASLEEVE6-5	•	•	•	•	•	•	6	45	16	16-5/8	45-1/8
8" Wall Sleeve Kit	for 29" Louver	ASLEEVE8-1	•	•	•	•		8	29	16	16-5/8	29-1/8	
	for 33" Louver	ASLEEVE8-2	•	•	•	•	•	8	32-3/4	16	16-5/8	32-7/8	
	for 45" Louver	ASLEEVE8-5	•	•	•	•	•	•	8	45	16	16-5/8	45-1/8
10" Wall Sleeve Kit	for 29" Louver	ASLEEVE10-1	•	•	•	•		10	29	16	16-5/8	29-1/8	
	for 33" Louver	ASLEEVE10-2	•	•	•	•	•	10	32-3/4	16	16-5/8	32-7/8	
	for 45" Louver	ASLEEVE10-5	•	•	•	•	•	•	10	45	16	16-5/8	45-1/8
12" Wall Sleeve Kit	for 29" Louver	ASLEEVE12-1	•	•	•	•		12	29	16	16-5/8	29-1/8	
	for 33" Louver	ASLEEVE12-2	•	•	•	•	•	12	32-3/4	16	16-5/8	32-7/8	
	for 45" Louver	ASLEEVE12-5	•	•	•	•	•	•	12	45	16	16-5/8	45-1/8

ACCESSORIES CONTINUED

	Accessory	Nomenclature	Magic-Pak Unit					
			**MGE4-11-091*P	**MGE4-11-121*P	**MGE4-11-181*P	**MGE4-11-241*P	**MGE4-11-301*P	**MGE4-11-361*P
Polypropylene Louvers	Polypropylene Louver Kit - White (29" Height / MGE)	ALVRPWHTMGE-1	•	•	•	•		
	Polypropylene Louver Kit - White (33" Height / MGE)	ALVRPWHTMGE-2					•	
	Polypropylene Louver Kit - Sandstone (29" Height / MGE)	ALVRPSANMGE-1	•	•	•	•		
	Polypropylene Louver Kit - Sandstone (33" Height / MGE)	ALVRPSANMGE-2					•	
	Polypropylene Louver Kit - Beige (29" Height / MGE)	ALVRPBGEMGE-1	•	•	•	•		
	Polypropylene Louver Kit - Beige (33" Height / MGE)	ALVRPBGEMGE-2					•	
	Polypropylene Louver Kit - Taupestone (29" Height / MGE)	ALVRPTPSTMGE-1	•	•	•	•		
	Polypropylene Louver Kit - Taupestone (33" Height / MGE)	ALVRPTPSTMGE-2					•	
Aluminum Louvers	Extruded Aluminum Louver Kit (29" Height)	ALVRAL-1	•	•	•	•		
	Extruded Aluminum Louver Kit - Custom Color (29" Height)	ALVRAL-1P	•	•	•	•		
	Extruded Aluminum Louver Kit (33" Height)	ALVRAL-2					•	
	Extruded Aluminum Louver Kit - Custom Color (33" Height)	ALVRAL-2P					•	
	Extruded Aluminum Louver Kit (45" Height)	ALVRAL-3	•	•	•	•		
	Extruded Aluminum Louver Kit - Custom Color (45" Height)	ALVRAL-3P	•	•	•	•		
	Extruded Aluminum Louver Kit (45" Height)	ALVRAL-4					•	•
	Extruded Aluminum Louver Kit - Custom Color (45" Height)	ALVRAL-4P					•	•
Impact Rated Louvers	Extruded Aluminum Louver Kit - Impact Rated (29" Height)	ALVRALC-1	•	•	•	•		
	Extruded Aluminum Louver Kit - Impact Rated / Custom Color (29" Height)	ALVRALC-1P	•	•	•	•		
	Extruded Aluminum Louver Kit - Impact Rated (33" Height)	ALVRALC-2					•	
	Extruded Aluminum Louver Kit - Impact Rated / Custom Color (33" Height)	ALVRALC-2P					•	
	Extruded Aluminum Louver Kit - Impact Rated (45" Height)	ALVRALC-3	•	•	•	•		
	Extruded Aluminum Louver Kit - Impact Rated / Custom Color (45" Height)	ALVRALC-3P	•	•	•	•		
	Extruded Aluminum Louver Kit - Impact Rated (45" Height)	ALVRALC-4					•	•
	Extruded Aluminum Louver Kit - Impact Rated / Custom Color (45" Height)	ALVRALC-4P					•	•

UNIT FILTER SIZE

Model	Filter Dimensions
All	12 X 24 X 1

ACCESSORIES CONTINUED

Accessory	Nomenclature	Magic-Pak Unit				
		15MGE4-11-**-1P	24MGE4-11-**-1P	36MGE4-11-**-1P	48MGE4-11-**-1P	60MGE4-11-**-1P
LP Conversion Kit	ALPKT613	•				
LP Conversion Kit	ALPKT614		•	•	•	•

HIGH ALTITUDE APPLICATION DATA

Altitude	Natural Gas		LP Gas	
	Burner Orifices	Manifold Pressure	Burner Orifices LP Kit	Manifold Pressure
0-5,500 ft	As shipped	3.5" w.c.	ALPKT613 or 614 (model dependent)	10.0" w.c.
5,500 - 8,500 ft.		3.0" w.c.		8.0" w.c.
Above 8,500 ft.	Per National Fuel Gas Code	3.5" w.c.	Per National Fuel Gas Code	10.0" w.c.

DIMENSIONS (IN.)

Model	A	B	C	D
*MGE4-11-091*P *MGE4-11-121*P	57-7/8	20-3/4	18-5/8	6
*MGE4-11-181*P *MGE4-11-241*P	59-7/8	22-3/4	20-5/8	
*MGE4-11-301*P	63-7/8	26-3/4	24-5/8	
*MGE4-11-361*P	71-7/8	34-3/4	28-5/8	10

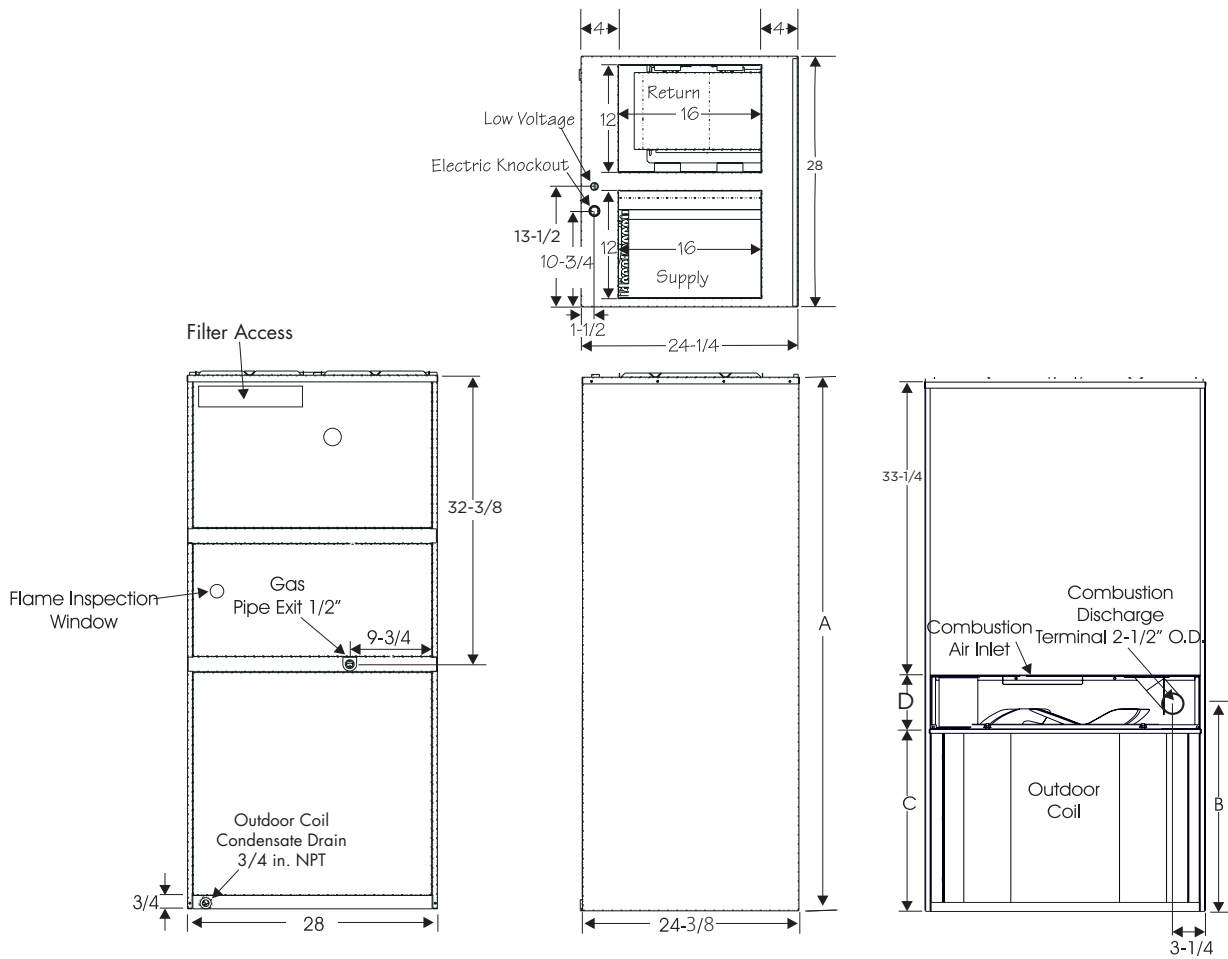



215 Metropolitan Drive | West Columbia, SC 29170
800-448-5872
Product Support 866-282-7257

All specifications and illustrations subject to change without notice and without incurring obligations.